



estudios energéticos consultores.
GRUPO MERCADOS ENERGÉTICOS CONSULTORES

INFORME DE DETERMINACIÓN DE POTENCIA MÁXIMA

Parque Eólico Cerro Tigre



Noviembre 2022

A 0668 | R 1067-21

Tabla de contenido

REGISTRO DE COMUNICACIONES	5
SECCIÓN PRINCIPAL	6
1. INTRODUCCIÓN	6
1.1. Marco normativo	6
1.2. Descripción de la planta	6
1.3. Descripción del control de planta y funcionalidades	13
1.4. Antecedentes de unidades de similares características	18
1.5. Descripción de las pruebas	18
2. RESULTADOS OBTENIDOS	18
2.1. Registros	18
2.2. CURVA DE POTENCIA DEL AEROGENERADOR	19
2.3. Pérdidas y consumos propios.....	21
2.4. Registros de las WT21, 22 y 78	25
3. CONCLUSIONES	25
ANEXO I: REGISTROS DE POTENCIA MÁXIMA.....	27

Índice de tablas y gráficos

Tabla 1. Valores máximos de pendiente y consigna de potencia activa.....	15
Tabla 2. Valores sugeridos de pendiente para la función limitación de rampa.	15
Tabla 3. Parametrización del modo LFSM-O.....	16
Tabla 4. Parametrización del modo FSM-O-U.	16
Tabla 5. Configuración de los límites PQ del control de potencia reactiva.....	17
Tabla 6. Tiempos asociados a la dinámica del control de potencia reactiva.	17
Tabla 7. Consumos servicios auxiliares aerogeneradores.....	23
Tabla 8. Parámetros de potencia máxima obtenidos.....	26
Gráfico 1. Esquema unilineal de la zona de influencia del PE Cerro Tigre.....	7
Gráfico 2. Esquema unilineal de la SE Cerro Tigre.....	9
Gráfico 3. Esquema unilineal del sistema colector en 33 kV. 1 de 3.	10
Gráfico 4. Esquema unilineal del sistema colector en 33 kV. 2 de 3.	11
Gráfico 5. Esquema unilineal del sistema colector en 33 kV. 3 de 3.	12
Gráfico 6. Curva de capacidad WTG Vestas V117-4.2 MW.	13
Gráfico 7. Esquema de control y medición del PE Cerro Tigre.....	14
Gráfico 8. Característica LFSM-O.	16
Gráfico 9. Característica FSM-O-U.	16
Gráfico 10. Límite PQ del control de potencia reactiva.....	17
Gráfico 11. Potencia activa en el punto de conexión (Potencia neta medida).....	19
Gráfico 12. Potencia activa, sumatoria de los aerogeneradores (Potencia bruta medida).....	19
Gráfico 13. Velocidad de viento promedio en los aerogeneradores.	19
Gráfico 14. Curva de potencia velocidad para el aerogenerador WTG71.	20
Gráfico 15. Determinación de la potencia neta máxima mediante Power Factory.....	21
Gráfico 16. Modelado del transformador de potencia de la SE Cerro Tigre.....	22
Gráfico 17. Aporte de máxima potencia en MT (parte 1).....	23
Gráfico 18. Aporte de máxima potencia en MT (parte 2).....	23
Gráfico 19. Despacho de generadores para potencia neta.	24
Gráfico 20. Potencia de pérdidas en equipos de transformación, cables y consumos propios.	25

Abreviaturas y acrónimos

CEN	Coordinador Eléctrico Nacional
CNE	Comisión Nacional de Energía
ERNC	Energía Renovables No Convencional
NTSyCS	Norma Técnica de Seguridad y Calidad de Servicio
NT SSMM	Norma Técnica de Seguridad y Calidad de Servicio para Sistemas Medianos
PE	Parque Eólico
SE	Subestación Eléctrica
AT	Alta tensión
MT	Media tensión
BT	Baja tensión
ONAN	Oil Natural Air Natural
ONAF	Oil Natural Air Forced
SEN	Sistema Eléctrico Nacional
RCB	Regulador Bajo Carga
PMU	Power Management Unit



REGISTRO DE COMUNICACIONES

Registro de las actividades, comunicaciones y aprobación de informes.

Número	Fecha dd/mm/año	Objeto	Ref	Observaciones	Responsable
1	14/01/2021	Emisión original	V1	Preparó EA - BL	FM
2	18/07/2022	Respuesta a observaciones - registros de 3 aerogeneradores faltantes	V2	Preparó EA	FM
3	30/11/2022	Se agrega tabla con detalle de potencias y pérdidas	V3	Preparó EA	FM

SECCIÓN PRINCIPAL

1. INTRODUCCIÓN

En el presente informe se exhiben los resultados obtenidos en los ensayos de campo realizados en el Parque Eólico Cerro Tigre, durante los días 13 y 14 de diciembre de 2021, en relación al proceso de determinación de los parámetros de potencia máxima de la planta.

Los ensayos fueron realizados encontrándose en servicio 41 de los 44 aerogeneradores que conforman la totalidad del parque (WT 21, 22 y 78 fuera de servicio). La potencia disponible al momento de las pruebas fue de 172,2 MW de un total de 184,8 MW.

El día 07/05/2022 se complementaron los registros con mediciones de las unidades 21, 22 y 78 a máxima potencia.

1.1. Marco normativo

Las pruebas realizadas se programaron en base al ANEXO TÉCNICO de la NTSyCS “Pruebas de Potencia Máxima en Unidades Generadoras”. En particular es de aplicación el Artículo 39 “Potencia Máxima en unidades generadoras cuya fuente es renovable no convencional sin capacidad de regulación” del TÍTULO VIII – CENTRALES CUYA FUENTE ES RENOVABLE NO CONVENCIONAL” al tratarse de una planta de ERNC sin capacidad de almacenamiento de energía. En tal sentido, el valor de Potencia Máxima se obtiene a partir de registros de operación y mediciones de los recursos naturales que inciden en la operación de estas tecnologías, especificándose las metodologías, cálculos y todos los antecedentes y aspectos técnicos usados para la obtención de dicho valor.

1.2. Descripción de la planta

El PE Cerro Tigre se encuentra ubicado a 65 km al suroeste de la ciudad de Antofagasta, en la región homónima de Chile. Está compuesto por 44 aerogeneradores de 4,2 MW marca Vestas, clase **V117-4.0/4.2 MW Strong Wind**, modelo **V117-4.2 MW IEC S / IEC IIA 50/60 Hz Power Optimized Mode (PO1)**, totalizando una potencia de 184,8 MW.

El punto de conexión del parque eólico corresponde a las barras de 220 kV de la SE Cerro Tigre y la vinculación al SEN se realiza a través de una línea de transmisión 1 x 220 kV de 12,7 km de longitud que une las SE Cerro Tigre y Farellón.

La distribución en media tensión se realiza mediante un sistema colector en 33 kV formado por 11 circuitos que recolectan la potencia de los aerogeneradores, y que acometen a la barra de 33 kV del transformador de potencia de 230/33 kV y 200 MVA (ONAF) de la SE Cerro Tigre.

En el Gráfico 1 se presenta un esquema unilineal de la zona de influencia, en el Gráfico 2 un esquema unilineal de la SE Cerro Tigre, y por último, en los Gráficos 3 a 5 se detalla el esquema unilineal del sistema colector en 33 kV.



Gráfico 1. Esquema unilíneal de la zona de influencia del PE Cerro Tigre.



Gráfico 2. Esquema unilínea de la SE Cerro Tigre.

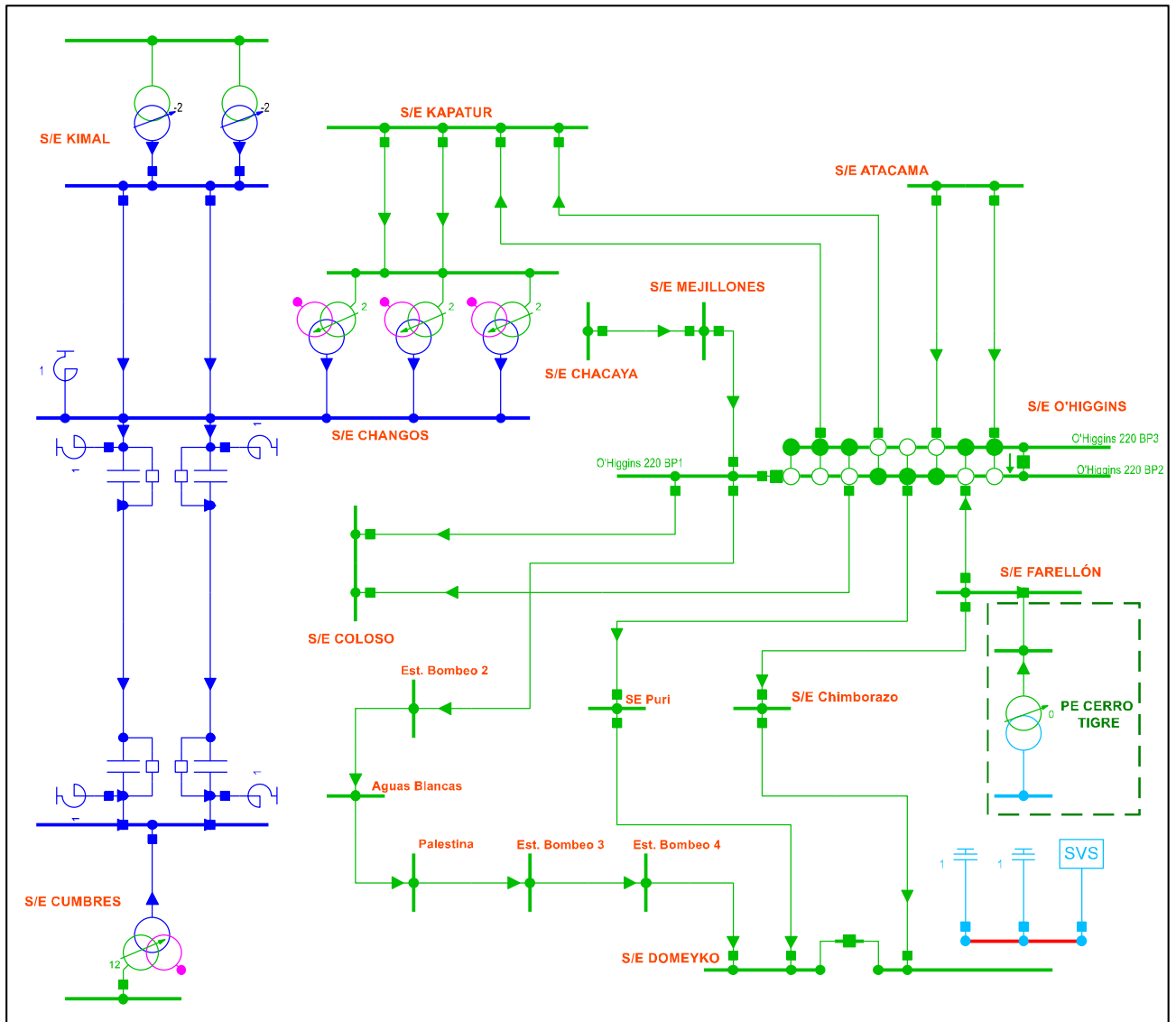

Gráfico 3. Esquema unilíneal del sistema colector en 33 kV. 1 de 3.

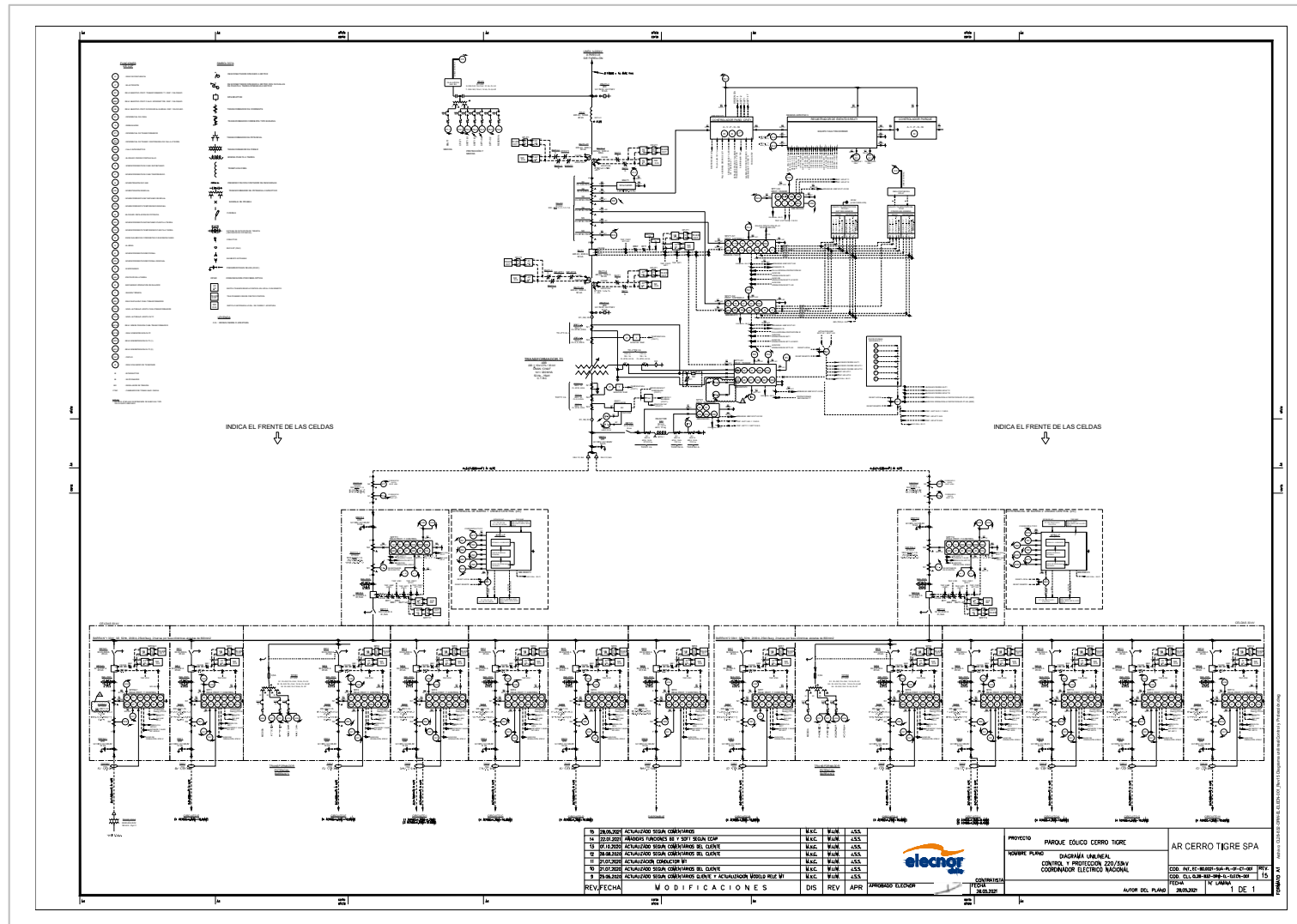

Gráfico 4. Esquema unilíneal del sistema colector en 33 kV. 2 de 3.

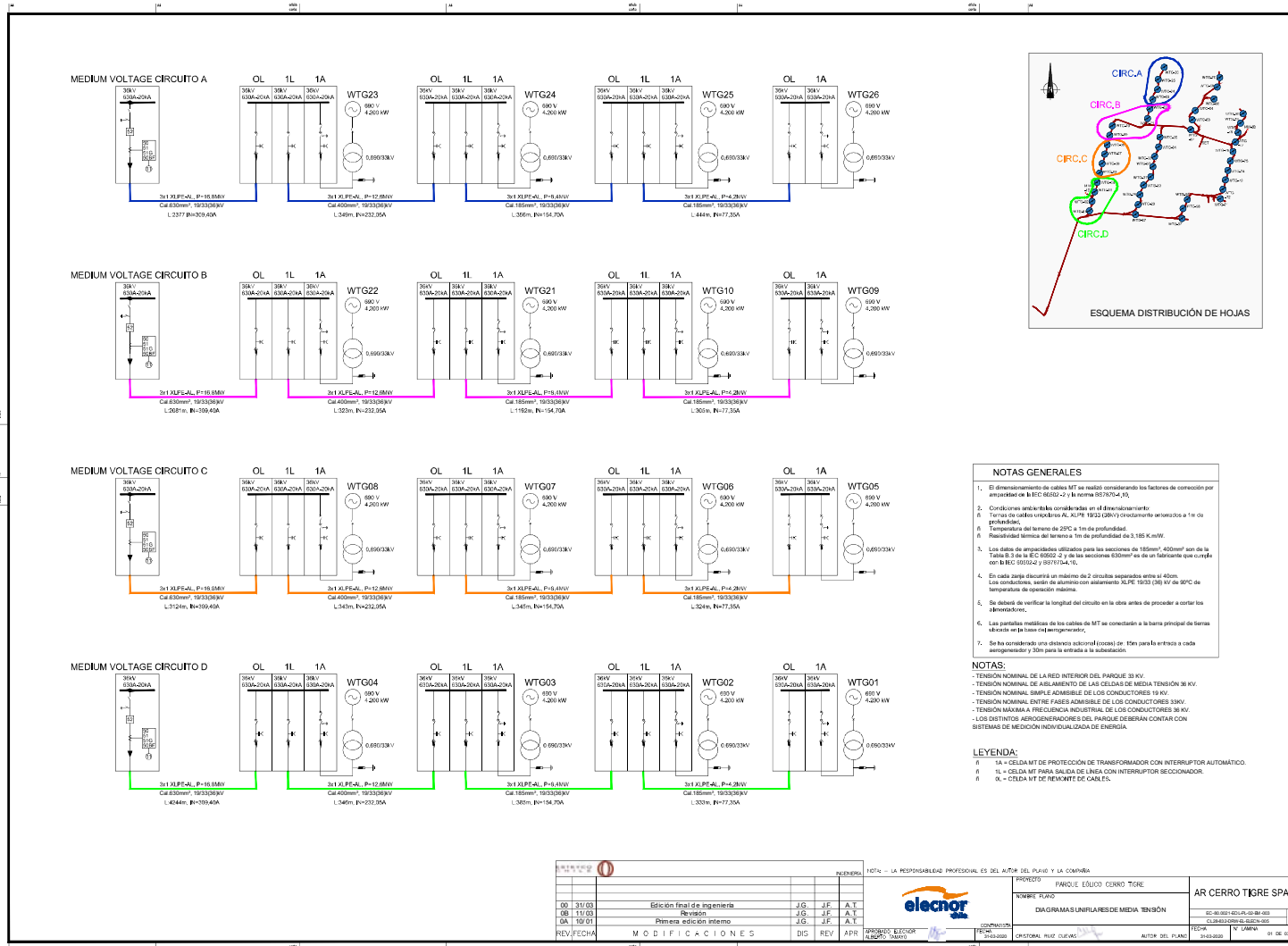

Gráfico 5. Esquema unilineal del sistema colector en 33 kV. 3 de 3.

Los aerogeneradores son de velocidad variable del tipo DFIG (Doubly Fed Asynchronous Generator). Cada unidad cuenta con un transformador de bloque de 0,72/33 kV y 5150 kVA.

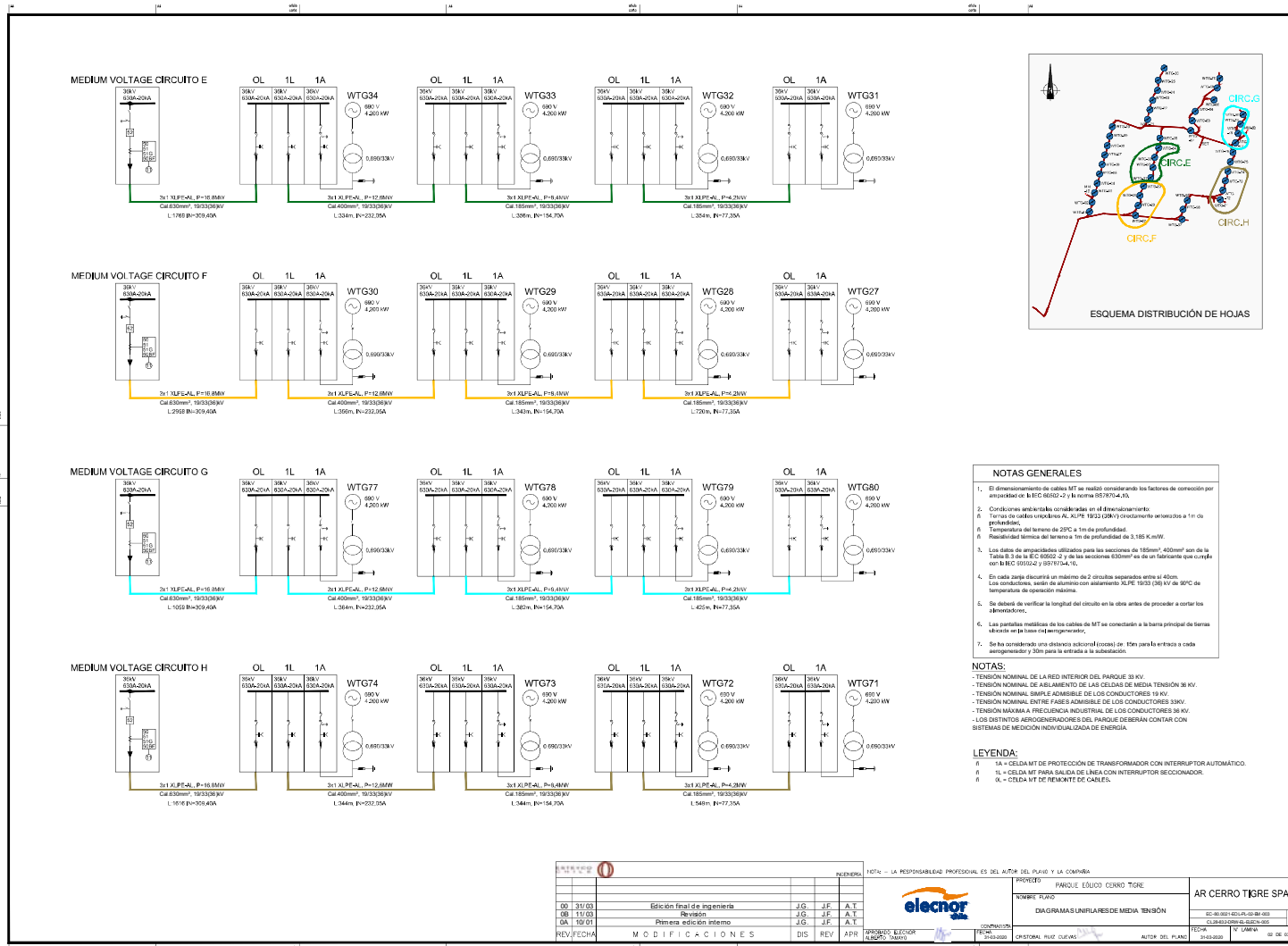
En el Gráfico 6 se presenta la curva de capacidad correspondiente al modelo de aerogenerador descrito.

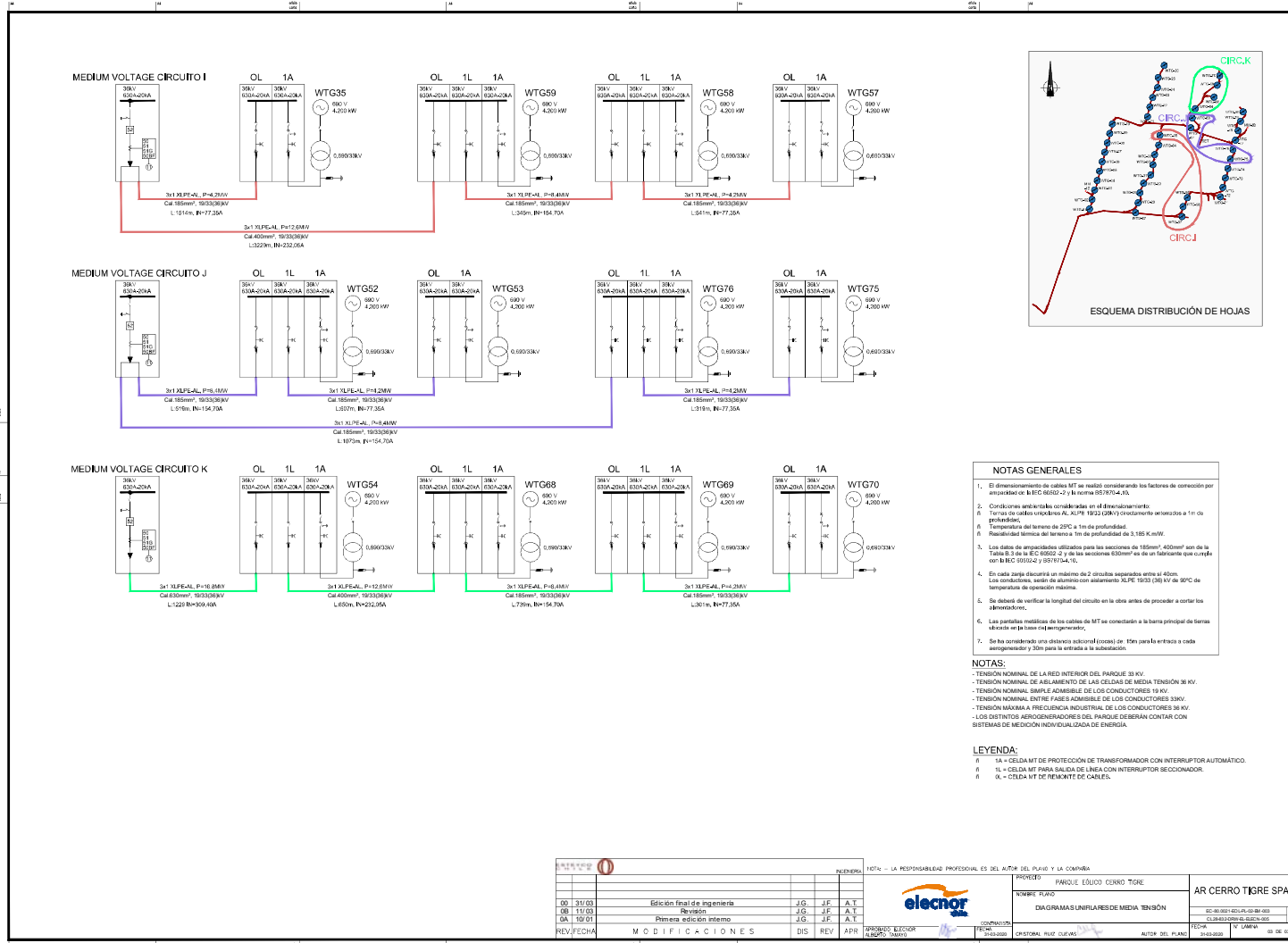

Gráfico 6. Curva de capacidad WTG Vestas V117-4.2 MW.

1.3. Descripción del control de planta y funcionalidades

El control del PE Cerro Tigre se realiza a través de un único PPC (Power Plant Controller) de Vestas mediante el sistema SCADA, siendo la barra de control del parque la situada eléctricamente en la barra de 220 kV de la SE Cerro Tigre.

En el siguiente gráfico se presenta un esquema del punto de medición (POM) y control del parque.

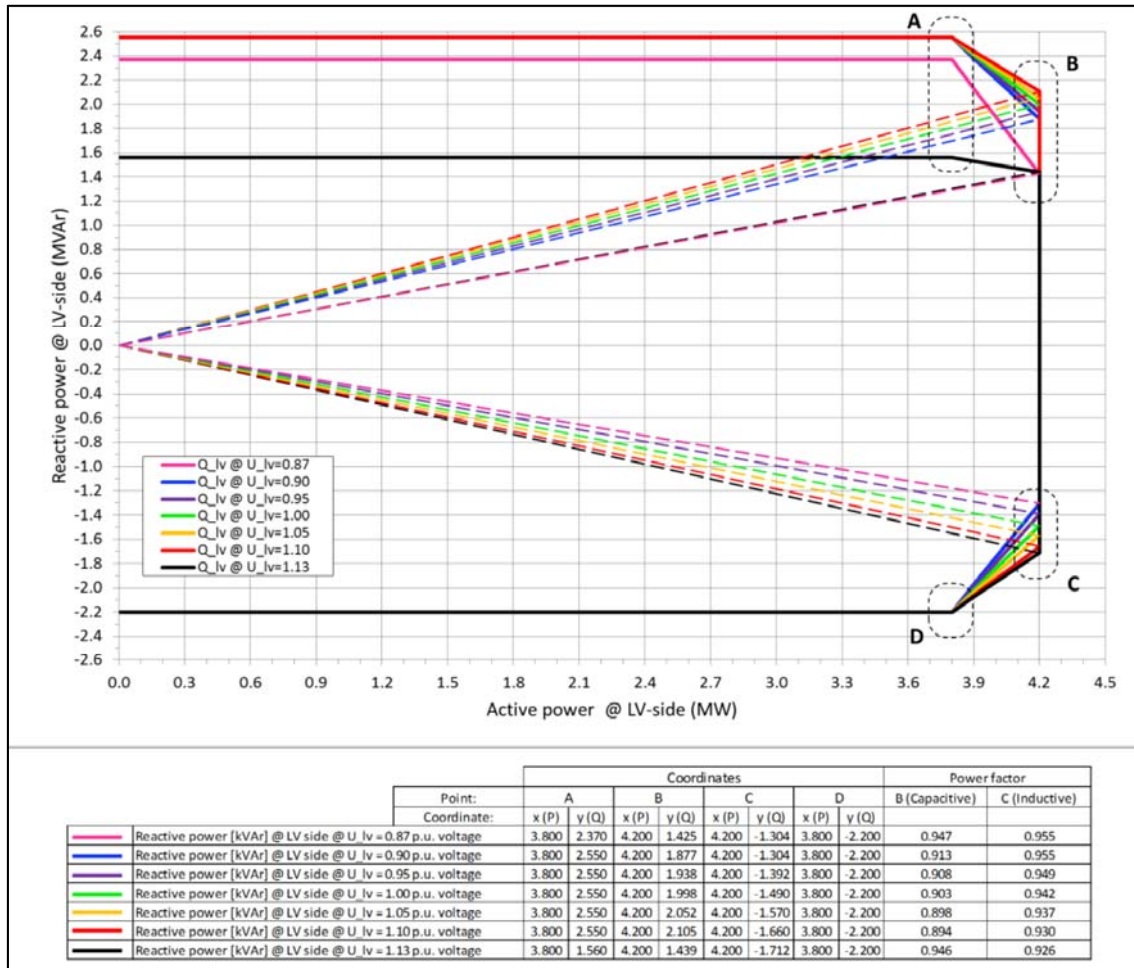

Gráfico 7. Esquema de control y medición del PE Cerro Tigre.

Por otro lado, el control de planta posee las siguientes funcionalidades:

- Funciones de control de potencia activa:
 - Control de potencia activa 0-100%.
 - Control de frecuencia.
- Funciones de control de potencia reactiva:
 - Control de tensión.
 - Control de potencia reactiva.
 - Control de factor de potencia.

El PPC envía las consignas de potencia activa y reactiva a los aerogeneradores. Además, el sistema SCADA permite enviar consignas de potencia activa y potencia reactiva individualmente a cada aerogenerador sin la participación del control del PPC (PPC desactivado).

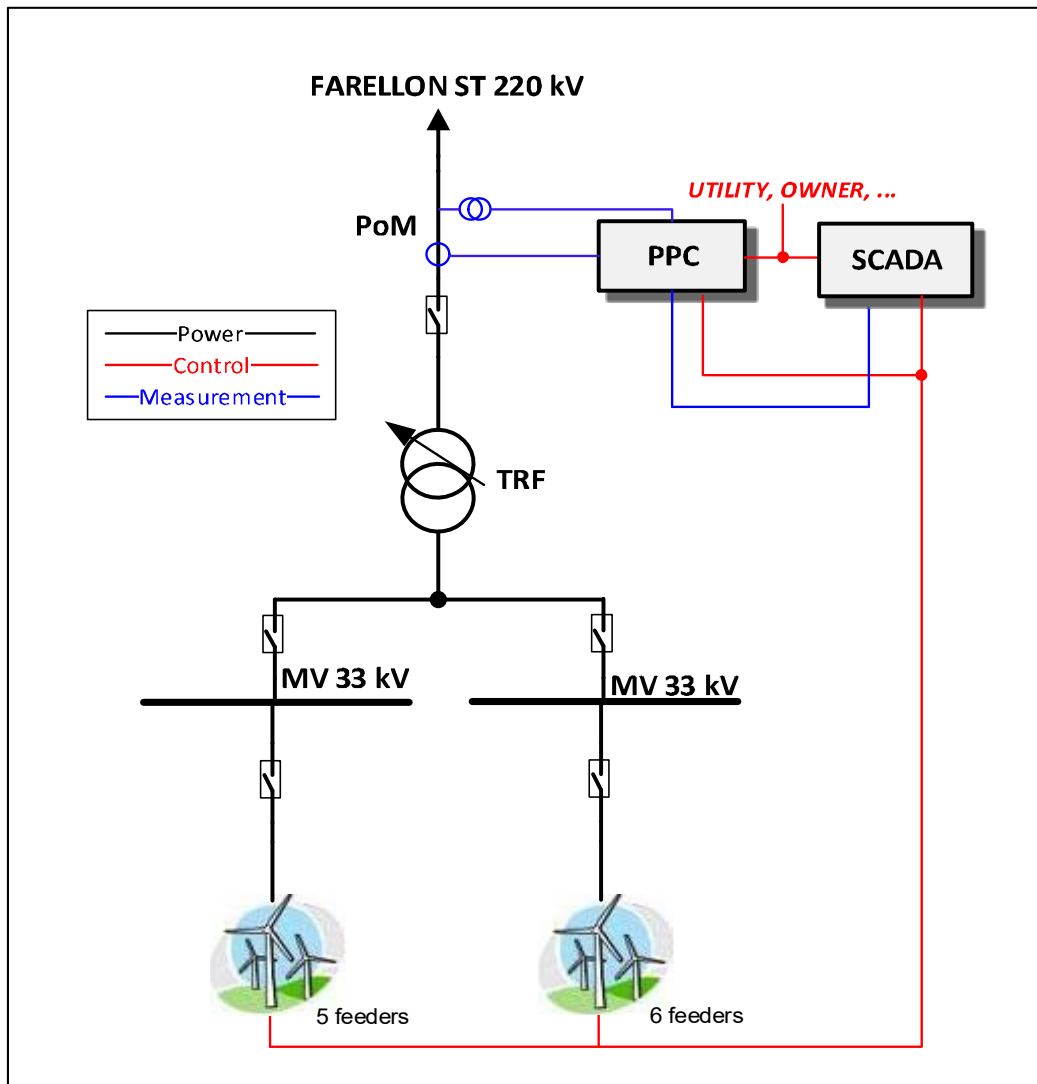
1.3.1. Funciones de control de potencia activa

El PPC podrá operar en dos modos diferentes de control:

- **Control de potencia activa de 0-100%:** permite ajustar la consigna de potencia activa a un valor determinado. Si se activa la función de limitación de rampa, tanto la rampa de bajada como de subida o toma de carga quedarán limitadas a una tasa de crecimiento determinada (en %/min). Si la función está desactivada, la reducción y la toma de carga se harán a una tasa que estará dada por la pendiente natural de los aerogeneradores (PrampLimit).

Con respecto al valor máximo de potencia activa, corresponde al 100% de la potencia nominal de la planta (184,8 MW).

La configuración sugerida por el fabricante y la limitación en el control de potencia activa se muestra a continuación:

Tabla 1. Valores máximos de pendiente y consigna de potencia activa.

P_{ref} maximum	184.8 MW
P_{ramp} limit (internal)	0.02 pu/s

A nivel PPC la tasa sugerida por defecto en este documento se muestra a continuación:

Tabla 2. Valores sugeridos de pendiente para la función limitación de rampa.

Active power output ramp	36960 kW/min (0.2 pu/min)
---------------------------------	---------------------------

Cabe aclarar que el PE Cerro Tigre posee una tasa ajustada en 20 %/min, cumpliendo con lo exigido por la normativa NTSyCS.

- **Control de frecuencia:** esta función contempla la respuesta de la potencia activa en función a las fluctuaciones de frecuencia respecto a la frecuencia nominal (50 Hz). La respuesta del parque estará dada por una curva de potencia frecuencia que posee una pendiente y una banda muerta. En los siguientes gráficos y tablas se detallan las curvas características y parametrización para ambos modos de control.



Gráfico 8. Característica LFSM-O.
Tabla 3. Parametrización del modo LFSM-O.

f4	50.2 Hz
fmax	52 Hz
f5	51.5 Hz
Pmin	28.5% of Pavailable
Slope_OF	3.64%
P ramp rate limit (default)	0.02 pu/s

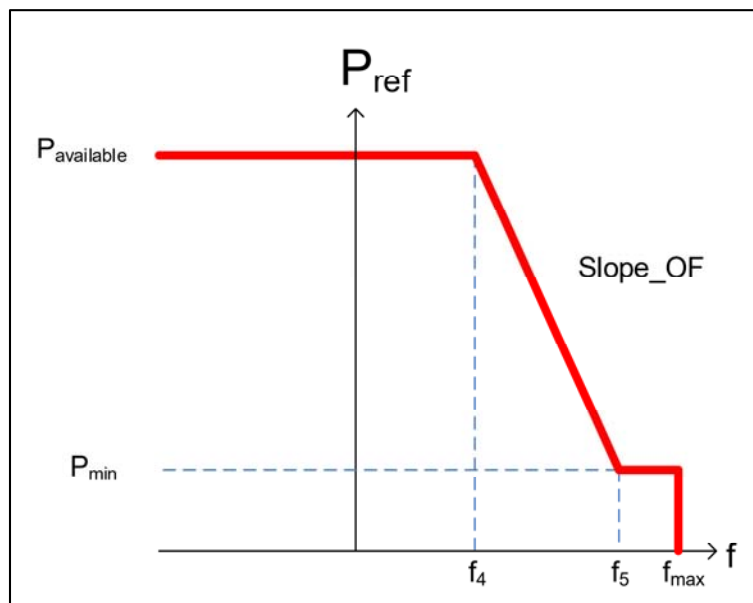

Gráfico 9. Característica FSM-O-U.

Tabla 4. Parametrización del modo FSM-O-U.

fmin	48 Hz
f0	$(f1 - (Pdelta [\%] \times Slope_UF / 100 / 100 \times 50))$ Hz
f1	49.8 Hz
SLOPE_UF	3.64%
Pdelta	Defined by WPP Operator or TSO (default: 3%)
f4	50.2 Hz
fmax	52 Hz
f5	51.5 Hz
Pmin	$((100 - 100 \times (f5 - f4) / 50 \times 100 / Slope_OF) \%) - Pdelta \%$
SLOPE_OF	3.64%
P ramp rate limit (default)	0.02 pu/s

El modo que se encuentra configurado en el parque es el modo LFSM-0.

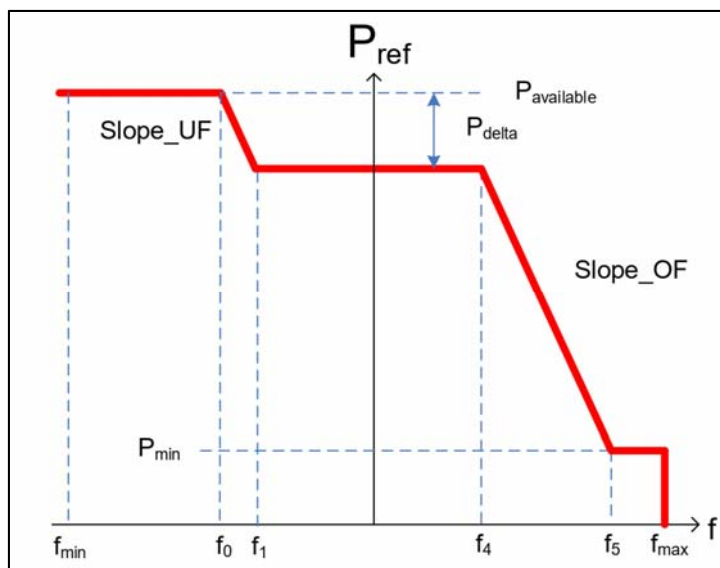
1.3.2. Funciones de control de potencia reactiva

- **Control de tensión PI:** permite definir un valor de consigna de tensión en el punto de control. Mediante un controlador de tipo proporcional-integral (PI), el control envía consignas de potencia reactiva a los aerogeneradores para mantener la tensión en la barra controlada en el valor especificado, reduciendo el error entre la tensión medida y la consigna o referencia a un valor de 0.
- **Control de potencia reactiva:** permite definir un valor de consigna de potencia reactiva en el punto de conexión, la cual es distribuida entre todas las unidades.

Según la información provista por el fabricante, los límites máximos de potencia reactiva son los siguientes:



Gráfico 10. Límite PQ del control de potencia reactiva.

Tabla 5. Configuración de los límites PQ del control de potencia reactiva.

PF limit capacitive	0.51
PF limit inductive	0.83
Q limit capacitive	60.8 MVar
Q limit inductive	60.8 MVar
Q _{ref} ramp rate limit	0.1 pu/s

Tabla 6. Tiempos asociados a la dinámica del control de potencia reactiva.

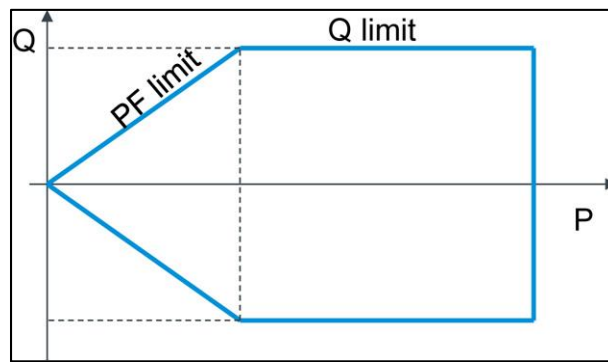
T ₀	Typical performance around 0.2 s
T _{rise}	3 s
T ₂	< 5 s

- **Control de factor de potencia:** permite definir un valor de consigna de factor de potencia en el punto de conexión, controlando la inyección de potencia reactiva para mantenerlo constante. Los límites de este modo de control están asociados a los correspondientes al control de potencia reactiva.

1.4. Antecedentes de unidades de similares características

El parque eólico presentó parámetros de desempeño equivalentes a parques eólicos de similares características tecnológicas, como, por ejemplo:

- PE Sierra Gorda Este.
- PE San Juan.

1.5. Descripción de las pruebas

La prueba se realizó en un lapso en el cual el recurso primario se mantuvo aproximadamente invariable, en las condiciones más cercanas a las nominales posibles, en cumplimiento con el Artículo 39 “Potencia Máxima en unidades generadoras cuya fuente es renovable no convencional sin capacidad de regulación” al tratarse de una planta de ERNC sin capacidad de almacenamiento de energía. La potencia máxima se obtuvo a partir de registros de operación y mediciones del recurso natural que incide en esta tecnología durante el día 13 de diciembre del 2021, incluyendo los antecedentes técnicos y los cálculos usados para obtener el valor. En el Anexo1 (adjunto con este informe) se detallan los valores registrados.

2. RESULTADOS OBTENIDOS

2.1. Registros

Se obtuvieron registros de potencia activa en el punto de conexión de la planta (barra de 220 kV de la SE Cerro Tigre (Gráfico 11), sumatoria de potencia activa de los aerogeneradores del parque (Gráfico 12) y la velocidad de viento en los aerogeneradores (Gráfico 13).



Gráfico 11. Potencia activa en el punto de conexión (Potencia neta medida).



Gráfico 12. Potencia activa, sumatoria de los aerogeneradores (Potencia bruta medida).

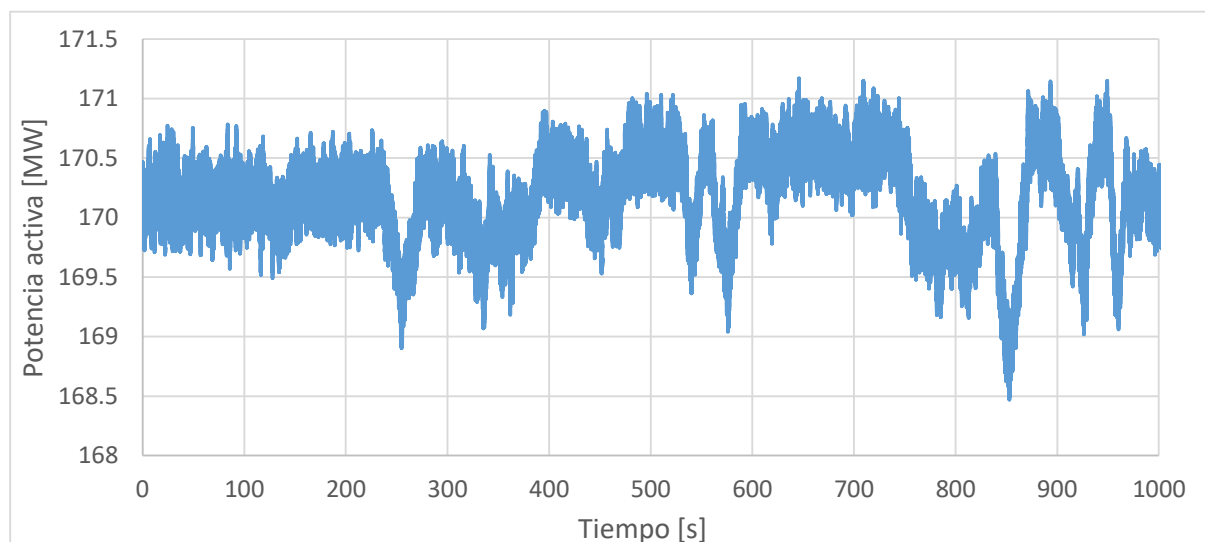

Gráfico 13. Velocidad de viento promedio en los aerogeneradores.

A partir de este registro, se observa una potencia neta promedio de 170,2 MW y una potencia bruta promedio de 172,8 MW para una velocidad de viento promedio de 15,5 m/s.

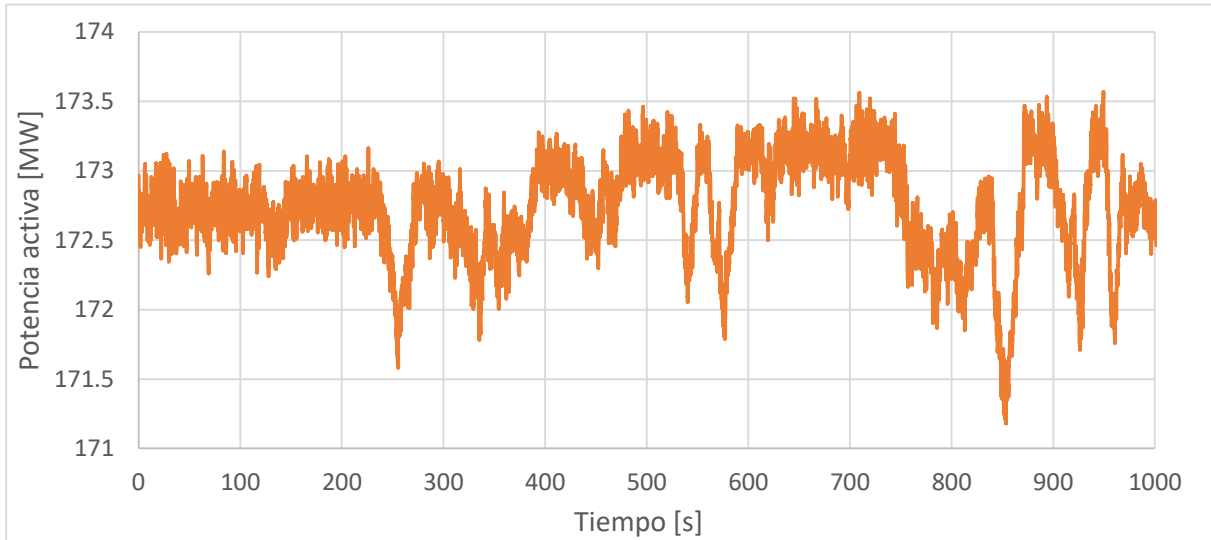
2.2. CURVA DE POTENCIA DEL AEROGENERADOR

A partir de los registros de velocidad y potencia individuales de un aerogenerador (WTG71), se verificó la curva de potencia - velocidad, registrando estos valores y contrastándola con la curva teórica del aerogenerador. El resultado se muestra en el siguiente gráfico:

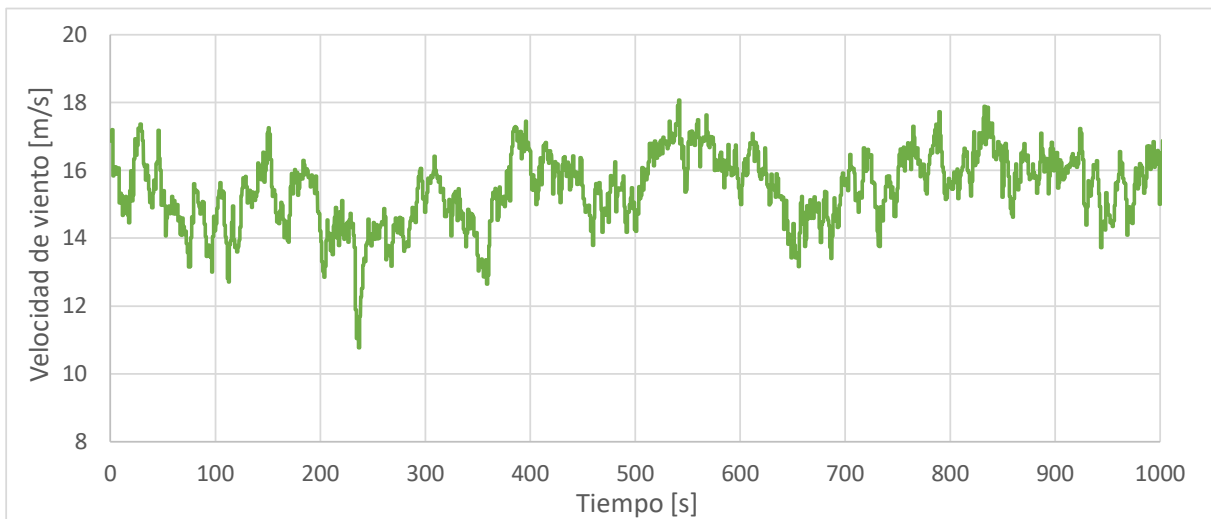

Gráfico 14. Curva de potencia velocidad para el aerogenerador WTG71.

Del gráfico se ve un resultado esperado en la potencia bruta para el aerogenerador seleccionado. Esto da idea de que, en caso de estar todos los aerogeneradores en servicio, se puede llegar a una potencia máxima, con la velocidad de viento existente en el momento de los ensayos.

Debido a que no se encontraban todos los aerogeneradores en servicio, se determina la potencia neta máxima del parque mediante simulación en Power Factory, utilizando el correspondiente modelo homologado. En el siguiente gráfico, puede observarse que, en caso de que estuviesen todos los aerogeneradores en servicio, es posible obtener una potencia neta máxima igual a 182,05 MW.

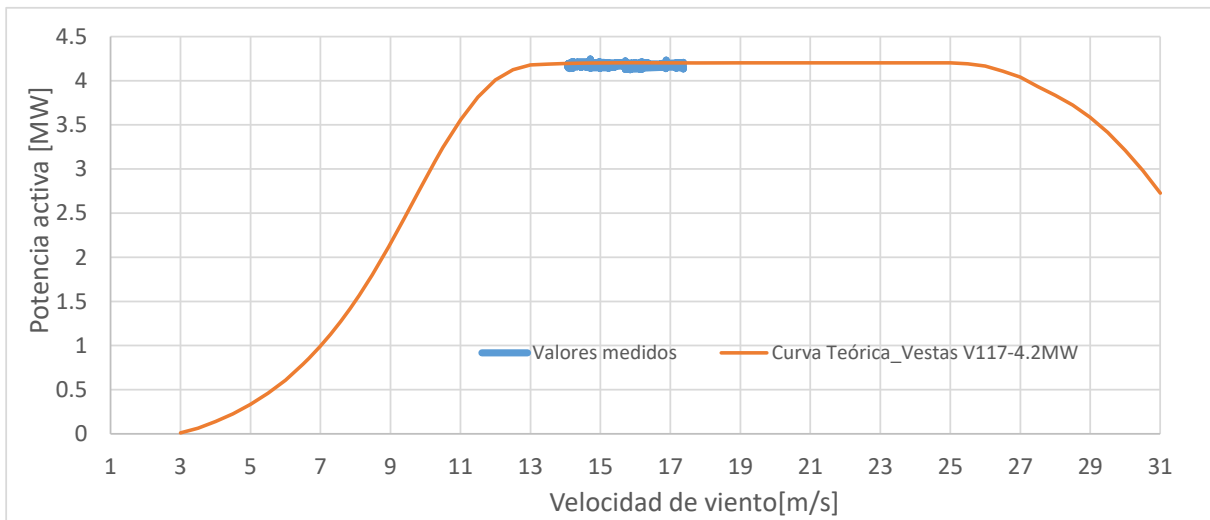

Gráfico 15. Determinación de la potencia neta máxima mediante Power Factory.

Así mismo la potencia bruta máxima será la potencia máxima asegurada en bornes de aerogenerador. Como el PE Cerro Tigre posee aerogeneradores con una potencia nominal de 4.2 MW, es posible calcular la potencia bruta máxima de la siguiente manera:

$$P_{bruta} = 44 \times 4,2 \text{ MW} = 184,8 \text{ MW}$$

2.3. Pérdidas y consumos propios

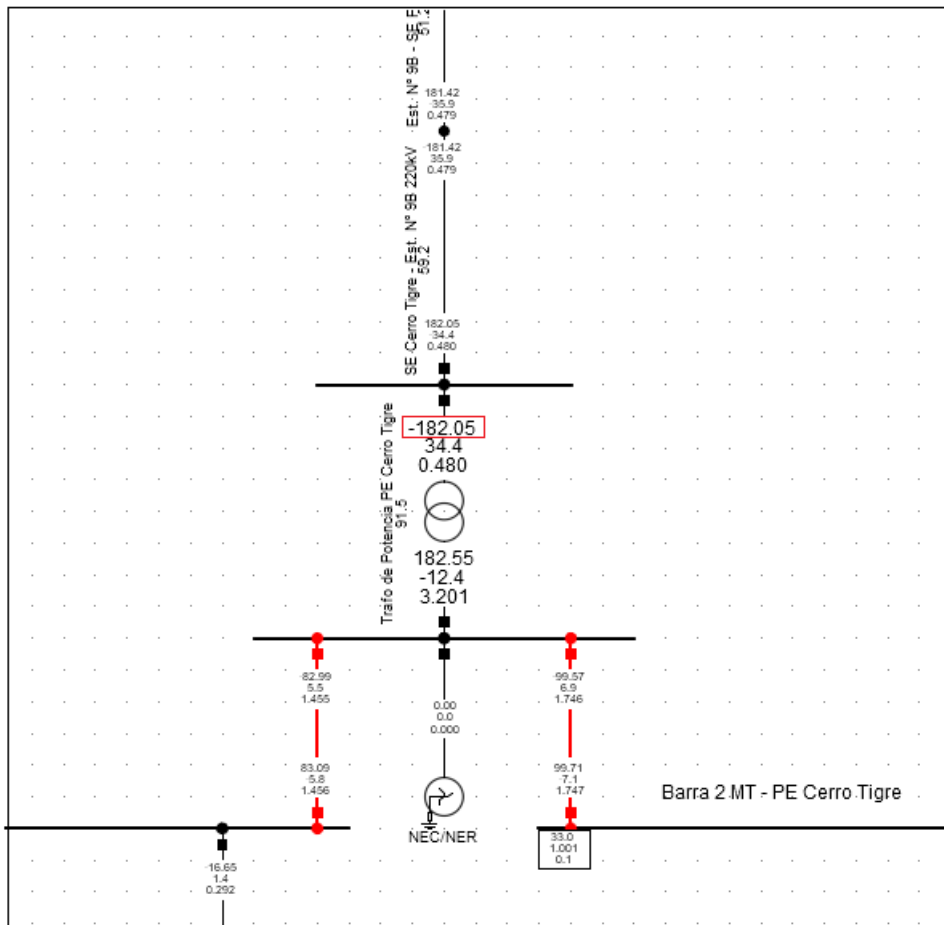
Las componentes que generan pérdidas respecto a la potencia bruta generada en el parque se pueden enumerar a continuación:

- Red de media tensión (circuitos colectores en 33 kV + transformadores de bloque de los aerogeneradores).
- Transformador de potencia de la subestación.
- Servicios auxiliares (aerogeneradores + subestación).

Para poder calcular las pérdidas de los elementos anteriores se procede a considerar una simulación estática (flujo de potencia) en el software PowerFactory, tomando el modelo empleado en el estudio de validación.

2.3.1. Cálculos de pérdidas asociadas al transformador de potencia de la SE Cerro Tigre.

Considerando la simulación de flujo de potencia teniendo en cuenta el estado de todos los

aerogeneradores que conforman el parque en servicio, se pueden determinar las pérdidas de potencia asociadas al transformador elevador de la SE Cerro Tigre, como la diferencia entre la potencia que recibe la barra colectora de 33 kV y la potencia en el lado de 220 kV del transformador. Esto último puede visualizarse en el Gráfico 15.

La potencia de pérdidas en el transformador, se calculan de la siguiente manera:

$$P_{trafo} = 182,55 \text{ MW} - 182.05 \text{ MW} = 500 \text{ kW}$$

En el siguiente gráfico se pueden observar los datos del transformador modelado.



Gráfico 16. Modelado del transformador de potencia de la SE Cerro Tigre.

2.3.2. Potencia inyectada en la barra de MT

La potencia inyectada en la red de MT se determina mediante flujo de potencia, considerando la condición de máxima potencia generada. En los siguientes gráficos se muestra el resultado obtenido.

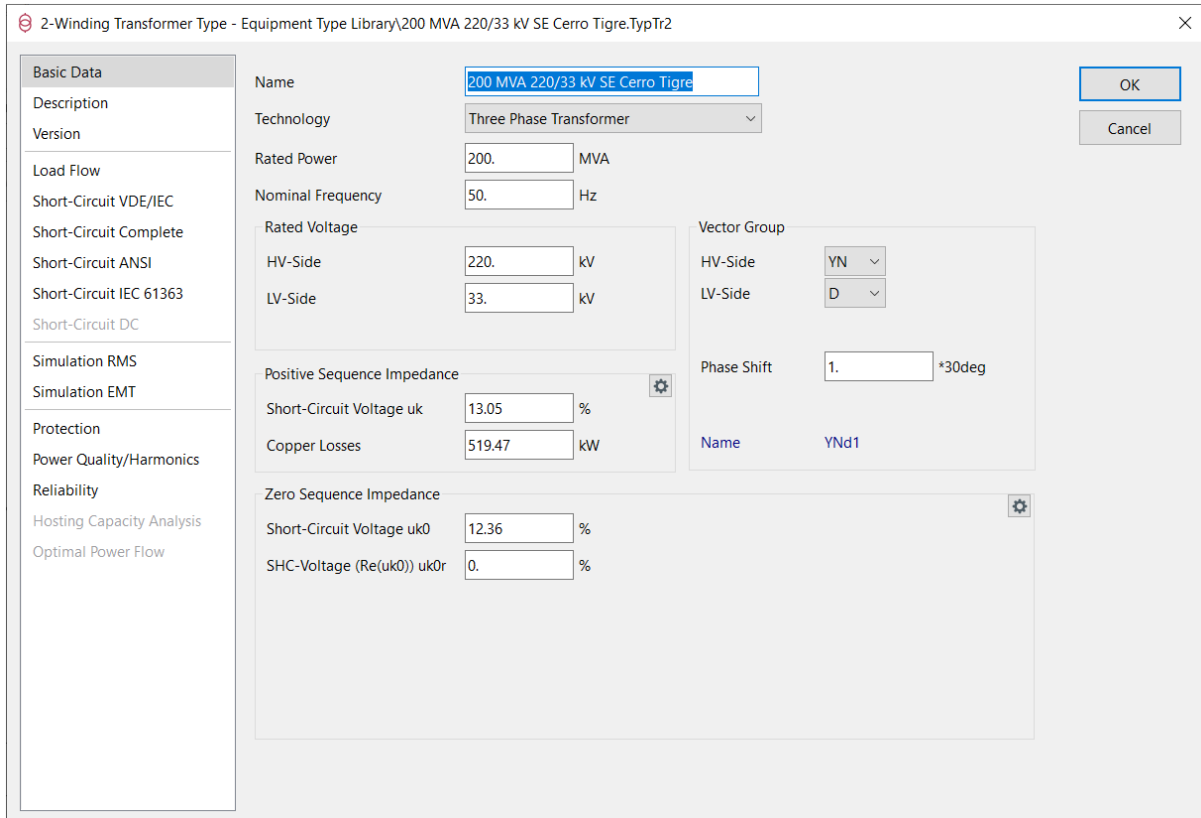

Gráfico 17. Aporte de máxima potencia en MT (parte 1)



Gráfico 18. Aporte de máxima potencia en MT (parte 2)

A partir de estos dos últimos gráficos, se tiene que la potencia aportada por la totalidad de la red colectora (P_{col}) es de 182,8 MW.

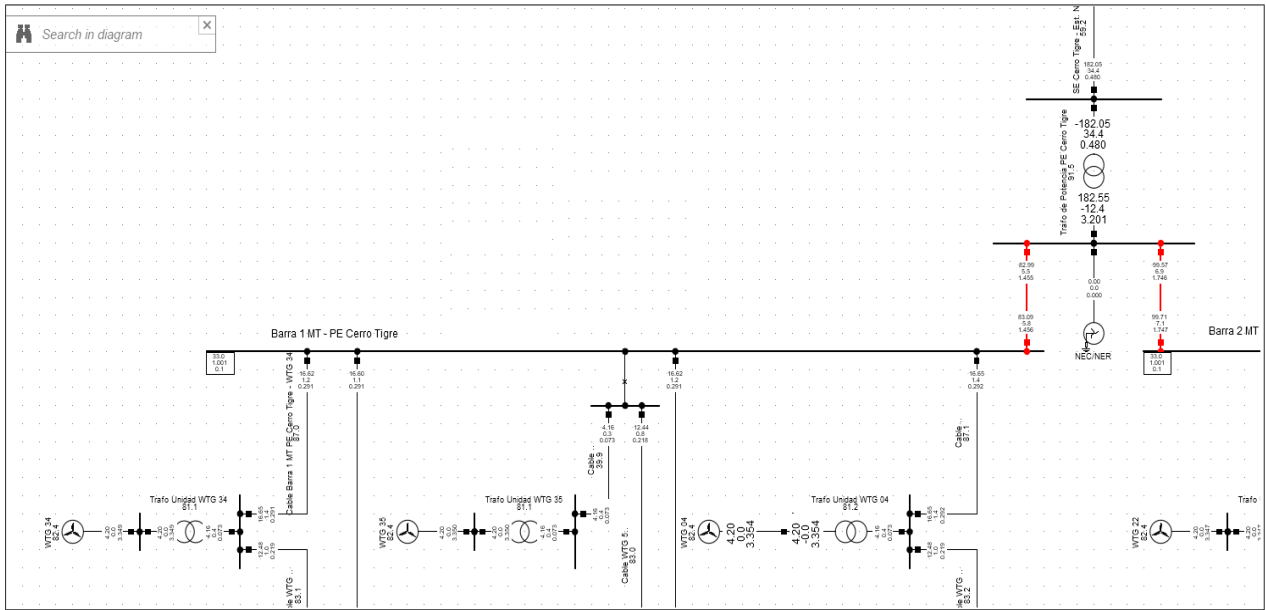
2.3.3. Consumo de servicios auxiliares

El consumo de servicios auxiliares (SSAA) de cada aerogenerador se determinó de acuerdo con el documento del fabricante VESTAS “Performance Specification VESTAS V117-4.2 MW Strong Wind”. En la siguiente tabla se muestran los consumos de SSAA asociadas a los aerogeneradores del PE.

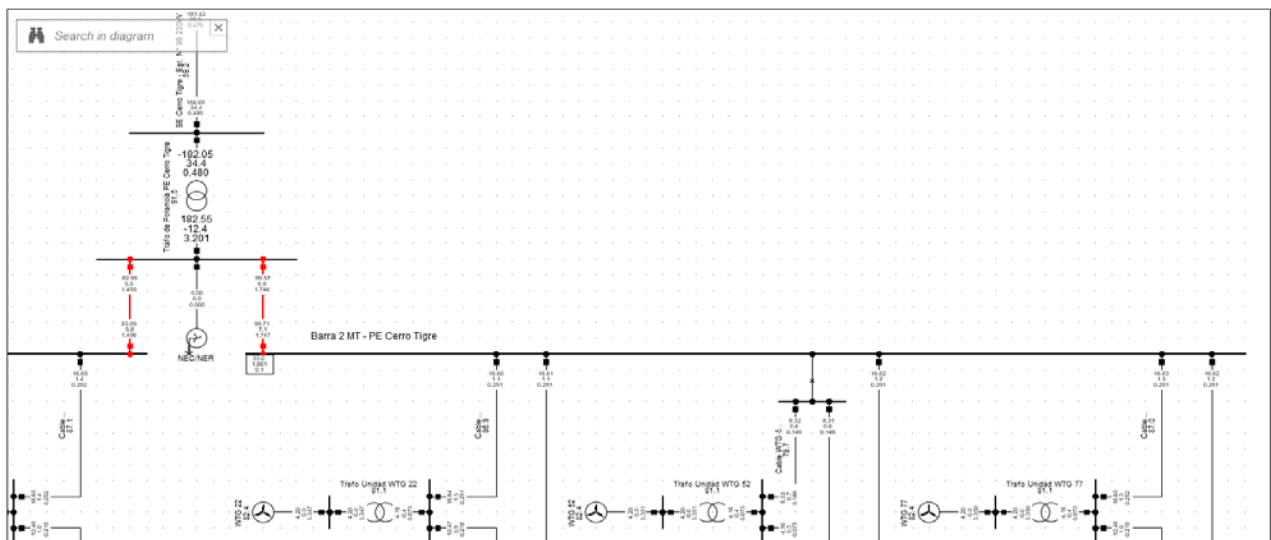
Tabla 7. Consumos servicios auxiliares aerogeneradores.

Elemento	Consumo kW
Consumo motor hidráulico	30
Motor de ajuste	21

Elemento	Consumo kW
Calefacción de agua	10
Bombas de agua	7.7
Calefacción de aceite	7.9
Bombeo de lubricantes	12.5
Sistema de control	3
Perdidas en vacío transformador	8.5
Total	100.6
Total (44 Aerogeneradores)	4426.4

Estas pérdidas son las máximas, sin considerar factores de simultaneidad y consumos asociados a calefacción que en estado de carga no estarían presentes.

Para determinar el consumo real a potencia máxima se realizó un cálculo de flujo de potencia donde se consideró el parque inyectando su potencia neta máxima en barras de AT de la SE Cerro Tigre.

Para esta condición de potencia neta máxima, los aerogeneradores quedan despachados como se muestra:



Gráfico 19. Despacho de generadores para potencia neta.

Esta potencia resulta luego descontar el consumo de servicios auxiliares de cada aerogenerador junto con las pérdidas en el transformador de unidad. Por lo tanto, la diferencia con la potencia bruta generada en la prueba resulta en el consumo de servicios auxiliares y las pérdidas en el transformador de unidad para esta condición operativa.

De lo anterior se determina el consumo total de servicios auxiliares como:

$$SS.AA_{aero} = 44 \times (4.2 - 4.16) = 1760 \text{ kW}$$

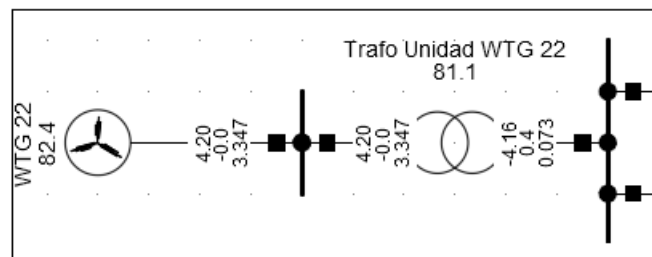
Con un consumo promedio de 40 kW por aerogenerador.

El consumo de servicios auxiliares de la SE Cerro Tigre se consideró en **100 kW**. De lo anterior, el consumo total de servicios auxiliares se calcula como:

$$SSAA = SSAA_{SE} + SSAA_{aero} = 1760 \text{ kW} + 100 \text{ kW} = 1860 \text{ kW}$$

Por otro lado, en el Gráfico 20 se observa la diferencia entre la potencia medida en el punto de conexión de la planta (Potencia Neta Medida con 41 aerogeneradores) y la potencia bruta medida. Esta diferencia corresponde a la potencia de pérdidas en el transformador de potencia del parque, los transformadores de cada aerogenerador, los cables de MT que conforman el sistema colector y los consumos propios de la planta.



Gráfico 20. Potencia de pérdidas en equipos de transformación, cables y consumos propios.

Se consideró entonces la potencia de pérdida promedio en el intervalo de generación máxima con 41 aerogeneradores es:

$$P_{perd} = 2,57 \text{ MW}$$

2.4. Registros de las WT21, 22 y 78

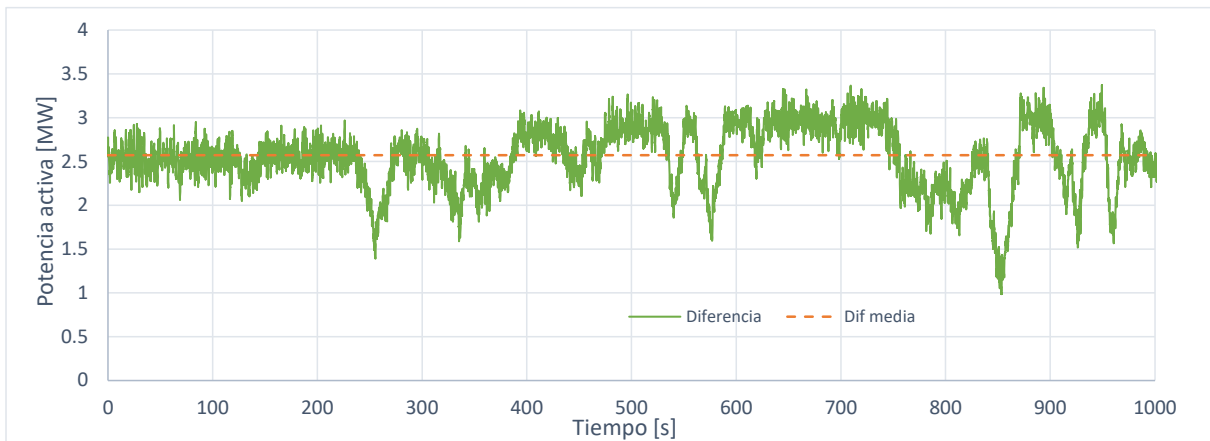
El día 14/12/2021 las WT 22 y 78 se encontraban fuera de servicio y la WT21 funcionaba por debajo de la potencia máxima. A continuación, se agregan registros del día 07/05/2022, con esas máquinas funcionando a plena carga durante más de dos horas:



Gráfico 21. Funcionamiento a plena carga de las unidades 21, 22 y 28

3. CONCLUSIONES

En relación a los ensayos realizados en campo y las simulaciones descritas en el presente informe, se concluye que el resultado de las pruebas realizadas fue satisfactorio, obteniéndose los parámetros indicados en la Tabla 8 :

Tabla 8. Parámetros de potencia máxima obtenidos.

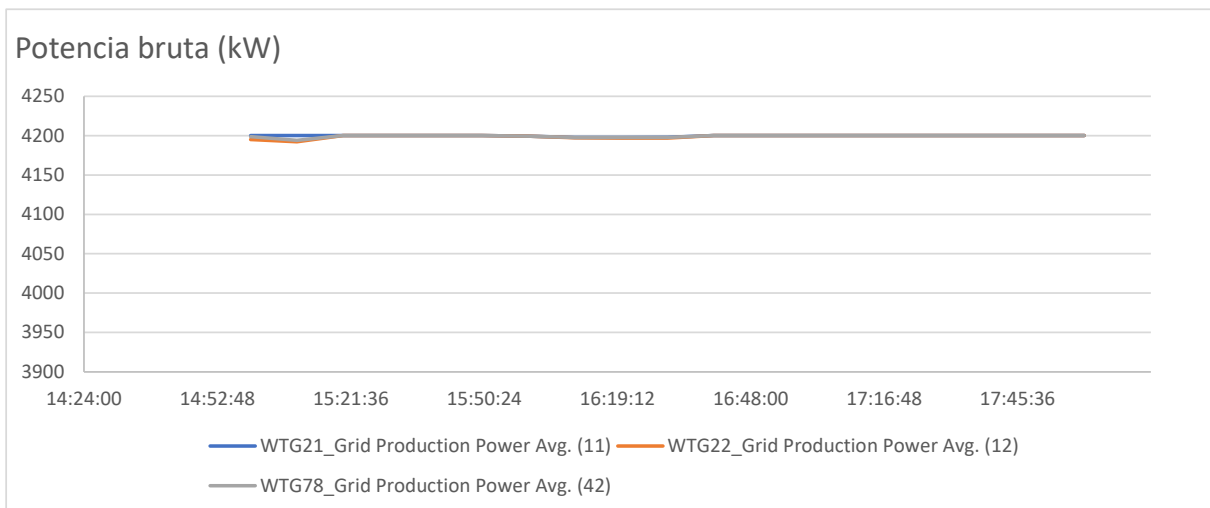
Parámetro	Valor
Potencia máxima bruta medida el 14/12/2021 (41 aerogeneradores)	172,8 MW
Potencia máxima neta medida el 14/12/2021 (41 aerogeneradores)	170,2 MW
Potencia máxima bruta con 44 aerogeneradores (incorporando mediciones del 07/05/2022)	184,8 MW
Potencia máxima neta con 44 aerogeneradores (incorporando mediciones del 07/05/2022)	182,05 MW

Tabla 9. Detalle de potencia máxima bruta, pérdida y potencia máxima neta con 44 aerogeneradores.

ELEMENTO	POTENCIA [MW]
Potencia Activa inyectada en la barra de 220 kV de la SE Cerro Tigre (punto de conexión del PE)	182.05
Pérdidas en el transformador de potencia del PE	0.5
Pérdidas totales del circuito colector (transformadores de bloque + red colectora de MT)	0.39
Consumo total de SSAA	1.86
Potencia máxima bruta	184.8

El valor de 184,8 MW se obtiene de sumar las mediciones de 41 aerogeneradores (de diciembre de 2021) y de los tres aerogeneradores restantes (07/05/2022).

Se hace notar que, en los registros presentados, el valor máximo (con 41 aerogeneradores) es de 173.458 MW, que surge de una medición instantánea con una resolución de 1 segundo. Este valor puede haberse originado de un transitorio (ráfaga) durante el cual los aerogeneradores pueden exceder su potencia máxima. No obstante, se recomienda mantener como valor de potencia bruta total el indicado por el fabricante, que es aquel que las unidades pueden proveer de forma continua.

ANEXO I: REGISTROS DE POTENCIA MÁXIMA

Registro	Pneta [MW]	Pbruta [MW]	Velocidad de viento [m/s]
2021-12-14T17:34:10	170.439	172.968	16.86
2021-12-14T17:34:11	170.418	172.797	16.86
2021-12-14T17:34:12	170.393	172.55	16.86
2021-12-14T17:34:13	170.464	172.585	16.86
2021-12-14T17:34:14	170.328	172.824	16.86
2021-12-14T17:34:15	170.401	172.631	16.86
2021-12-14T17:34:16	170.463	172.977	16.86
2021-12-14T17:34:17	170.188	172.79	16.86
2021-12-14T17:34:18	170.367	172.723	16.86
2021-12-14T17:34:19	170.313	172.748	16.86
2021-12-14T17:34:20	170.226	172.768	16.87
2021-12-14T17:34:21	170.285	172.465	16.87
2021-12-14T17:34:22	170.322	172.513	16.87
2021-12-14T17:34:23	170.172	172.895	16.87
2021-12-14T17:34:24	170.269	172.838	16.87
2021-12-14T17:34:25	170.232	172.609	16.87
2021-12-14T17:34:26	170.181	172.701	16.87
2021-12-14T17:34:27	170.192	173.033	16.87
2021-12-14T17:34:28	170.178	172.682	16.87
2021-12-14T17:34:29	170.083	172.662	16.87
2021-12-14T17:34:30	170.179	172.971	16.87
2021-12-14T17:34:31	170.158	172.629	16.87
2021-12-14T17:34:32	170.045	172.556	16.87
2021-12-14T17:34:33	170.067	172.936	16.87
2021-12-14T17:34:34	170.151	172.654	16.87
2021-12-14T17:34:35	170.155	172.82	16.87
2021-12-14T17:34:36	170.088	172.722	16.87
2021-12-14T17:34:37	170.233	172.562	16.87
2021-12-14T17:34:38	170.265	172.677	16.87
2021-12-14T17:34:39	170.185	172.999	16.87
2021-12-14T17:34:40	170.282	172.387	16.87
2021-12-14T17:34:41	170.204	172.635	16.87
2021-12-14T17:34:42	170.106	172.975	16.87
2021-12-14T17:34:43	170.308	172.428	16.87
2021-12-14T17:34:44	170.269	172.791	16.87
2021-12-14T17:34:45	170.247	172.754	17.2
2021-12-14T17:34:46	170.371	172.708	17.2
2021-12-14T17:34:47	170.38	172.486	17.2
2021-12-14T17:34:48	170.282	172.601	17.2
2021-12-14T17:34:49	170.365	172.657	17.2
2021-12-14T17:34:50	170.353	172.682	17.2
2021-12-14T17:34:51	170.273	172.543	17.2

2021-12-14T17:34:52	170.355	172.616	17.2
2021-12-14T17:34:53	170.393	172.757	17.2
2021-12-14T17:34:54	170.178	172.89	17.2
2021-12-14T17:34:55	170.301	172.701	17.2
2021-12-14T17:34:56	170.32	172.629	17.2
2021-12-14T17:34:57	170.229	172.623	17.2
2021-12-14T17:34:58	170.263	172.944	17.2
2021-12-14T17:34:59	170.314	172.747	17.2
2021-12-14T17:35:00	170.172	172.805	17.2
2021-12-14T17:35:01	170.284	172.753	17.2
2021-12-14T17:35:02	170.216	172.706	17.2
2021-12-14T17:35:03	170.156	172.84	17.2
2021-12-14T17:35:04	170.295	172.703	17.2
2021-12-14T17:35:05	170.131	172.664	17.2
2021-12-14T17:35:06	170.278	172.741	17.2
2021-12-14T17:35:07	170.268	172.702	17.2
2021-12-14T17:35:08	170.169	172.583	17.2
2021-12-14T17:35:09	170.245	172.734	17.2
2021-12-14T17:35:10	170.302	172.796	15.84
2021-12-14T17:35:11	170.233	172.707	15.84
2021-12-14T17:35:12	170.321	172.645	15.84
2021-12-14T17:35:13	170.162	173.106	15.84
2021-12-14T17:35:14	170.291	172.736	15.84
2021-12-14T17:35:15	170.36	172.493	15.84
2021-12-14T17:35:16	170.096	172.779	15.84
2021-12-14T17:35:17	170.296	172.745	15.84
2021-12-14T17:35:18	170.269	172.705	15.84
2021-12-14T17:35:19	170.117	172.451	15.84
2021-12-14T17:35:20	170.273	172.625	15.84
2021-12-14T17:35:21	170.213	172.697	15.84
2021-12-14T17:35:22	170.197	172.618	15.84
2021-12-14T17:35:23	170.234	172.82	15.84
2021-12-14T17:35:24	170.114	172.897	15.84
2021-12-14T17:35:25	170.221	172.669	15.84
2021-12-14T17:35:26	170.186	172.694	15.84
2021-12-14T17:35:27	170.196	172.871	15.84
2021-12-14T17:35:28	170.215	172.758	15.84
2021-12-14T17:35:29	170.172	172.647	15.84
2021-12-14T17:35:30	170.246	172.796	15.84
2021-12-14T17:35:31	170.066	172.699	15.84
2021-12-14T17:35:32	170.141	172.942	15.84
2021-12-14T17:35:33	170.315	172.457	15.84
2021-12-14T17:35:34	170.173	172.976	15.84
2021-12-14T17:35:35	170.115	172.638	15.92
2021-12-14T17:35:36	170.32	172.406	15.92

2021-12-14T17:35:37	170.192	172.745	15.92
2021-12-14T17:35:38	170.171	172.732	15.92
2021-12-14T17:35:39	170.225	172.587	15.92
2021-12-14T17:35:40	170.183	172.77	15.92
2021-12-14T17:35:41	170.181	172.895	15.92
2021-12-14T17:35:42	170.198	172.626	15.92
2021-12-14T17:35:43	170.206	172.619	15.92
2021-12-14T17:35:44	170.21	172.746	15.92
2021-12-14T17:35:45	170.244	172.866	15.92
2021-12-14T17:35:46	170.242	172.462	15.92
2021-12-14T17:35:47	170.146	172.775	15.92
2021-12-14T17:35:48	170.17	172.694	15.92
2021-12-14T17:35:49	170.256	172.676	15.92
2021-12-14T17:35:50	170.109	172.733	15.92
2021-12-14T17:35:51	170.093	172.845	15.92
2021-12-14T17:35:52	170.238	172.761	15.92
2021-12-14T17:35:53	169.969	172.593	15.92
2021-12-14T17:35:54	169.978	172.825	15.92
2021-12-14T17:35:55	170.195	172.817	15.92
2021-12-14T17:35:56	169.934	172.923	15.92
2021-12-14T17:35:57	169.991	172.654	15.92
2021-12-14T17:35:58	170.099	172.725	15.92
2021-12-14T17:35:59	169.974	172.717	15.92
2021-12-14T17:36:00	169.993	172.706	16.11
2021-12-14T17:36:01	169.98	172.632	16.11
2021-12-14T17:36:02	169.955	172.862	16.11
2021-12-14T17:36:03	170.016	172.914	16.11
2021-12-14T17:36:04	169.971	172.684	16.11
2021-12-14T17:36:05	170.055	172.604	16.11
2021-12-14T17:36:06	170.012	173.022	16.11
2021-12-14T17:36:07	169.998	172.525	16.11
2021-12-14T17:36:08	170.055	172.457	16.11
2021-12-14T17:36:09	169.948	172.945	16.11
2021-12-14T17:36:10	169.973	172.755	16.11
2021-12-14T17:36:11	169.983	172.659	16.11
2021-12-14T17:36:12	169.932	172.721	16.11
2021-12-14T17:36:13	170.006	172.706	16.11
2021-12-14T17:36:14	169.933	172.663	16.11
2021-12-14T17:36:15	169.91	172.549	16.11
2021-12-14T17:36:16	170.012	172.604	16.11
2021-12-14T17:36:17	169.906	172.625	16.11
2021-12-14T17:36:18	169.937	172.427	16.11
2021-12-14T17:36:19	170.004	172.48	16.11
2021-12-14T17:36:20	169.888	172.545	16.11
2021-12-14T17:36:21	169.946	172.559	16.11

2021-12-14T17:36:22	169.96	172.599	16.11
2021-12-14T17:36:23	169.947	172.514	16.11
2021-12-14T17:36:24	169.984	172.525	16.11
2021-12-14T17:36:25	169.943	172.337	15.89
2021-12-14T17:36:26	170.032	172.692	15.89
2021-12-14T17:36:27	170.053	172.549	15.89
2021-12-14T17:36:28	169.988	172.632	15.89
2021-12-14T17:36:29	170.076	172.614	15.89
2021-12-14T17:36:30	170.046	172.463	15.89
2021-12-14T17:36:31	169.923	172.595	15.89
2021-12-14T17:36:32	170.091	172.446	15.89
2021-12-14T17:36:33	170.056	172.76	15.89
2021-12-14T17:36:34	169.997	172.464	15.89
2021-12-14T17:36:35	170.109	172.709	15.89
2021-12-14T17:36:36	169.95	172.719	15.89
2021-12-14T17:36:37	169.989	172.833	15.89
2021-12-14T17:36:38	170.043	172.761	15.89
2021-12-14T17:36:39	169.997	172.777	15.89
2021-12-14T17:36:40	169.958	172.823	15.89
2021-12-14T17:36:41	170.059	172.919	15.89
2021-12-14T17:36:42	169.955	172.721	15.89
2021-12-14T17:36:43	169.871	172.644	15.89
2021-12-14T17:36:44	170.013	172.749	15.89
2021-12-14T17:36:45	169.99	172.91	15.89
2021-12-14T17:36:46	169.804	172.79	15.89
2021-12-14T17:36:47	169.863	172.684	15.89
2021-12-14T17:36:48	169.927	172.723	15.89
2021-12-14T17:36:49	169.879	172.79	15.89
2021-12-14T17:36:50	169.895	172.816	15.96
2021-12-14T17:36:51	169.927	172.628	15.96
2021-12-14T17:36:52	169.776	172.899	15.96
2021-12-14T17:36:53	169.919	172.698	15.96
2021-12-14T17:36:54	169.85	172.866	15.96
2021-12-14T17:36:55	169.755	172.862	15.96
2021-12-14T17:36:56	169.844	172.855	15.96
2021-12-14T17:36:57	169.861	172.859	15.96
2021-12-14T17:36:58	169.927	172.779	15.96
2021-12-14T17:36:59	169.883	172.736	15.96
2021-12-14T17:37:00	169.778	172.592	15.96
2021-12-14T17:37:01	169.906	172.816	15.96
2021-12-14T17:37:02	169.879	172.826	15.96
2021-12-14T17:37:03	169.792	172.789	15.96
2021-12-14T17:37:04	169.923	172.753	15.96
2021-12-14T17:37:05	169.893	172.843	15.96
2021-12-14T17:37:06	169.783	172.655	15.96

2021-12-14T17:37:07	169.849	172.932	15.96
2021-12-14T17:37:08	169.73	172.805	15.96
2021-12-14T17:37:09	169.898	172.688	15.96
2021-12-14T17:37:10	169.799	172.92	15.96
2021-12-14T17:37:11	169.724	172.847	15.96
2021-12-14T17:37:12	169.925	172.68	15.96
2021-12-14T17:37:13	169.831	172.678	15.96
2021-12-14T17:37:14	169.879	172.54	15.96
2021-12-14T17:37:15	169.997	172.532	16.07
2021-12-14T17:37:16	169.792	173.034	16.07
2021-12-14T17:37:17	169.916	172.95	16.07
2021-12-14T17:37:18	170.042	172.661	16.07
2021-12-14T17:37:19	169.969	172.788	16.07
2021-12-14T17:37:20	170.058	172.93	16.07
2021-12-14T17:37:21	170.06	172.792	16.07
2021-12-14T17:37:22	170.007	172.705	16.07
2021-12-14T17:37:23	170.118	172.898	16.07
2021-12-14T17:37:24	170.032	172.677	16.07
2021-12-14T17:37:25	170.233	172.7	16.07
2021-12-14T17:37:26	170.112	172.918	16.07
2021-12-14T17:37:27	169.98	172.665	16.07
2021-12-14T17:37:28	170.203	172.731	16.07
2021-12-14T17:37:29	170.118	173.048	16.07
2021-12-14T17:37:30	170.163	172.767	16.07
2021-12-14T17:37:31	170.228	172.759	16.07
2021-12-14T17:37:32	170.17	172.972	16.07
2021-12-14T17:37:33	170.149	172.74	16.07
2021-12-14T17:37:34	170.206	172.538	16.07
2021-12-14T17:37:35	170.2	172.708	16.07
2021-12-14T17:37:36	170.178	172.884	16.07
2021-12-14T17:37:37	170.206	172.678	16.07
2021-12-14T17:37:38	170.136	172.772	16.07
2021-12-14T17:37:39	169.99	172.731	16.07
2021-12-14T17:37:40	170.14	172.954	15.04
2021-12-14T17:37:41	170.187	172.748	15.04
2021-12-14T17:37:42	170.018	172.872	15.04
2021-12-14T17:37:43	170.127	172.703	15.04
2021-12-14T17:37:44	170.189	172.769	15.04
2021-12-14T17:37:45	170.015	173.005	15.04
2021-12-14T17:37:46	170.115	172.684	15.04
2021-12-14T17:37:47	170.26	172.861	15.04
2021-12-14T17:37:48	169.991	172.772	15.04
2021-12-14T17:37:49	170.108	172.618	15.04
2021-12-14T17:37:50	170.279	172.778	15.04
2021-12-14T17:37:51	169.973	172.935	15.04

2021-12-14T17:37:52	170.198	172.632	15.04
2021-12-14T17:37:53	170.244	172.784	15.04
2021-12-14T17:37:54	170.133	172.612	15.04
2021-12-14T17:37:55	170.202	172.689	15.04
2021-12-14T17:37:56	170.144	173.087	15.04
2021-12-14T17:37:57	170.2	172.644	15.04
2021-12-14T17:37:58	170.214	172.794	15.04
2021-12-14T17:37:59	170.168	172.82	15.04
2021-12-14T17:38:00	170.211	172.795	15.04
2021-12-14T17:38:01	170.098	172.921	15.04
2021-12-14T17:38:02	170.162	172.696	15.04
2021-12-14T17:38:03	170.202	172.852	15.04
2021-12-14T17:38:04	170.134	172.755	15.04
2021-12-14T17:38:05	170.142	172.965	15.33
2021-12-14T17:38:06	170.148	172.831	15.33
2021-12-14T17:38:07	169.994	172.561	15.33
2021-12-14T17:38:08	170.236	172.692	15.33
2021-12-14T17:38:09	170.105	172.696	15.33
2021-12-14T17:38:10	170.047	172.485	15.33
2021-12-14T17:38:11	170.249	172.713	15.33
2021-12-14T17:38:12	170.105	172.557	15.33
2021-12-14T17:38:13	170.12	172.613	15.33
2021-12-14T17:38:14	170.205	172.511	15.33
2021-12-14T17:38:15	170.188	172.585	15.33
2021-12-14T17:38:16	170.162	172.34	15.33
2021-12-14T17:38:17	170.228	172.315	15.33
2021-12-14T17:38:18	170.204	172.408	15.33
2021-12-14T17:38:19	170.155	172.172	15.33
2021-12-14T17:38:20	170.232	172.336	15.33
2021-12-14T17:38:21	170.258	172.141	15.33
2021-12-14T17:38:22	170.202	172.069	15.33
2021-12-14T17:38:23	170.199	172	15.33
2021-12-14T17:38:24	170.183	171.834	15.33
2021-12-14T17:38:25	170.156	171.644	15.33
2021-12-14T17:38:26	170.165	171.977	15.33
2021-12-14T17:38:27	170.235	171.936	15.33
2021-12-14T17:38:28	170.007	171.848	15.33
2021-12-14T17:38:29	170.122	172.076	15.33
2021-12-14T17:38:30	170.239	172.216	15.27
2021-12-14T17:38:31	170.031	172.177	15.27
2021-12-14T17:38:32	170.09	172.066	15.27
2021-12-14T17:38:33	170.102	172.375	15.27
2021-12-14T17:38:34	169.969	172.281	15.27
2021-12-14T17:38:35	170.048	172.087	15.27
2021-12-14T17:38:36	170.024	172.107	15.27

2021-12-14T17:38:37	169.962	172.439	15.27
2021-12-14T17:38:38	169.923	172.316	15.27
2021-12-14T17:38:39	170.052	172.447	15.27
2021-12-14T17:38:40	170.205	172.592	15.27
2021-12-14T17:38:41	169.988	172.597	15.27
2021-12-14T17:38:42	169.972	172.792	15.27
2021-12-14T17:38:43	170.135	172.502	15.27
2021-12-14T17:38:44	169.993	172.938	15.27
2021-12-14T17:38:45	170.063	172.753	15.27
2021-12-14T17:38:46	170.202	172.748	15.27
2021-12-14T17:38:47	169.979	172.752	15.27
2021-12-14T17:38:48	170.18	172.853	15.27
2021-12-14T17:38:49	170.205	172.825	15.27
2021-12-14T17:38:50	170.107	172.805	15.27
2021-12-14T17:38:51	170.21	172.79	15.27
2021-12-14T17:38:52	170.081	172.846	15.27
2021-12-14T17:38:53	170.062	172.611	15.27
2021-12-14T17:38:54	170.052	172.875	15.27
2021-12-14T17:38:55	170.08	172.538	14.67
2021-12-14T17:38:56	170.149	172.809	14.67
2021-12-14T17:38:57	170.006	172.637	14.67
2021-12-14T17:38:58	170.01	172.637	14.67
2021-12-14T17:38:59	170	172.693	14.67
2021-12-14T17:39:00	169.918	172.702	14.67
2021-12-14T17:39:01	169.955	172.658	14.67
2021-12-14T17:39:02	169.978	172.743	14.67
2021-12-14T17:39:03	169.832	172.756	14.67
2021-12-14T17:39:04	169.993	172.793	14.67
2021-12-14T17:39:05	169.894	173.042	14.67
2021-12-14T17:39:06	169.855	172.859	14.67
2021-12-14T17:39:07	169.984	172.689	14.67
2021-12-14T17:39:08	170.014	172.823	14.67
2021-12-14T17:39:09	169.973	172.887	14.67
2021-12-14T17:39:10	170.012	172.616	14.67
2021-12-14T17:39:11	169.959	172.779	14.67
2021-12-14T17:39:12	170.014	172.953	14.67
2021-12-14T17:39:13	170.004	172.835	14.67
2021-12-14T17:39:14	169.972	172.594	14.67
2021-12-14T17:39:15	170.122	172.873	14.67
2021-12-14T17:39:16	169.976	172.828	14.67
2021-12-14T17:39:17	170.184	172.381	14.67
2021-12-14T17:39:18	170.06	172.606	14.67
2021-12-14T17:39:19	169.967	172.492	14.67
2021-12-14T17:39:20	170.11	172.493	14.73
2021-12-14T17:39:21	170.009	172.568	14.73

2021-12-14T17:39:22	169.937	172.407	14.73
2021-12-14T17:39:23	170.156	172.467	14.73
2021-12-14T17:39:24	170.033	172.626	14.73
2021-12-14T17:39:25	169.939	172.612	14.73
2021-12-14T17:39:26	170.077	172.964	14.73
2021-12-14T17:39:27	169.893	172.792	14.73
2021-12-14T17:39:28	170.001	172.629	14.73
2021-12-14T17:39:29	170.107	172.422	14.73
2021-12-14T17:39:30	169.994	172.569	14.73
2021-12-14T17:39:31	170	172.695	14.73
2021-12-14T17:39:32	170.084	172.38	14.73
2021-12-14T17:39:33	170.021	172.482	14.73
2021-12-14T17:39:34	169.957	172.404	14.73
2021-12-14T17:39:35	170.052	172.408	14.73
2021-12-14T17:39:36	170.036	172.43	14.73
2021-12-14T17:39:37	169.995	172.441	14.73
2021-12-14T17:39:38	169.975	172.137	14.73
2021-12-14T17:39:39	170.068	172.396	14.73
2021-12-14T17:39:40	169.911	172.338	14.73
2021-12-14T17:39:41	170.012	172.102	14.73
2021-12-14T17:39:42	170.125	172.287	14.73
2021-12-14T17:39:43	169.898	172.284	14.73
2021-12-14T17:39:44	170.043	172.232	14.73
2021-12-14T17:39:45	170.148	171.947	14.74
2021-12-14T17:39:46	170.03	172.188	14.74
2021-12-14T17:39:47	170.191	172.156	14.74
2021-12-14T17:39:48	170.184	172.153	14.74
2021-12-14T17:39:49	170.069	172.29	14.74
2021-12-14T17:39:50	170.194	172.434	14.74
2021-12-14T17:39:51	170.197	172.434	14.74
2021-12-14T17:39:52	170.109	172.487	14.74
2021-12-14T17:39:53	170.021	172.713	14.74
2021-12-14T17:39:54	170.028	172.354	14.74
2021-12-14T17:39:55	170.134	172.703	14.74
2021-12-14T17:39:56	169.978	172.406	14.74
2021-12-14T17:39:57	170.224	172.555	14.74
2021-12-14T17:39:58	170.173	172.573	14.74
2021-12-14T17:39:59	169.961	172.437	14.74
2021-12-14T17:40:00	170.252	172.561	14.74
2021-12-14T17:40:01	170.114	172.461	14.74
2021-12-14T17:40:02	170.118	172.25	14.74
2021-12-14T17:40:03	170.263	172.099	14.74
2021-12-14T17:40:04	170.008	172.138	14.74
2021-12-14T17:40:05	170.211	172.286	14.74
2021-12-14T17:40:06	170.359	172.231	14.74

2021-12-14T17:40:07	170.081	172.26	14.74
2021-12-14T17:40:08	170.304	172.544	14.74
2021-12-14T17:40:09	170.29	172.406	14.74
2021-12-14T17:40:10	170.129	172.456	15.23
2021-12-14T17:40:11	170.403	172.588	15.23
2021-12-14T17:40:12	170.385	172.25	15.23
2021-12-14T17:40:13	170.173	172.441	15.23
2021-12-14T17:40:14	170.379	172.474	15.23
2021-12-14T17:40:15	170.311	172.605	15.23
2021-12-14T17:40:16	170.145	172.414	15.23
2021-12-14T17:40:17	170.366	172.694	15.23
2021-12-14T17:40:18	170.16	172.611	15.23
2021-12-14T17:40:19	170.145	172.65	15.23
2021-12-14T17:40:20	170.163	172.743	15.23
2021-12-14T17:40:21	170.355	172.619	15.23
2021-12-14T17:40:22	170.279	172.542	15.23
2021-12-14T17:40:23	170.148	172.538	15.23
2021-12-14T17:40:24	170.171	172.433	15.23
2021-12-14T17:40:25	170.356	172.471	15.23
2021-12-14T17:40:26	170.203	172.391	15.23
2021-12-14T17:40:27	170.19	172.557	15.23
2021-12-14T17:40:28	170.171	172.435	15.23
2021-12-14T17:40:29	170.206	172.416	15.23
2021-12-14T17:40:30	170.205	172.481	15.23
2021-12-14T17:40:31	170.215	172.53	15.23
2021-12-14T17:40:32	170.208	172.364	15.23
2021-12-14T17:40:33	170.172	172.52	15.23
2021-12-14T17:40:34	170.209	172.631	15.23
2021-12-14T17:40:35	170.193	172.68	14.91
2021-12-14T17:40:36	170.179	172.669	14.91
2021-12-14T17:40:37	170.246	172.847	14.91
2021-12-14T17:40:38	170.29	172.968	14.91
2021-12-14T17:40:39	170.176	172.882	14.91
2021-12-14T17:40:40	170.352	172.886	14.91
2021-12-14T17:40:41	170.348	172.782	14.91
2021-12-14T17:40:42	170.194	173.033	14.91
2021-12-14T17:40:43	170.29	173.008	14.91
2021-12-14T17:40:44	170.323	173.167	14.91
2021-12-14T17:40:45	170.242	173.008	14.91
2021-12-14T17:40:46	170.256	173.056	14.91
2021-12-14T17:40:47	170.302	173.094	14.91
2021-12-14T17:40:48	170.357	173.031	14.91
2021-12-14T17:40:49	170.155	172.942	14.91
2021-12-14T17:40:50	170.154	172.864	14.91
2021-12-14T17:40:51	170.225	172.96	14.91

2021-12-14T17:40:52	170.054	172.836	14.91
2021-12-14T17:40:53	170.171	173.028	14.91
2021-12-14T17:40:54	170.183	173.164	14.91
2021-12-14T17:40:55	169.961	173.191	14.91
2021-12-14T17:40:56	170.11	172.988	14.91
2021-12-14T17:40:57	170.104	172.944	14.91
2021-12-14T17:40:58	169.916	173.127	14.91
2021-12-14T17:40:59	170.141	172.934	14.91
2021-12-14T17:41:00	170.059	173.008	14.68
2021-12-14T17:41:01	169.949	173.186	14.68
2021-12-14T17:41:02	169.948	172.988	14.68
2021-12-14T17:41:03	170.036	173.053	14.68
2021-12-14T17:41:04	169.996	172.958	14.68
2021-12-14T17:41:05	169.997	172.988	14.68
2021-12-14T17:41:06	169.95	173.092	14.68
2021-12-14T17:41:07	170.007	173.054	14.68
2021-12-14T17:41:08	170.014	173.004	14.68
2021-12-14T17:41:09	169.992	173.195	14.68
2021-12-14T17:41:10	170.092	172.934	14.68
2021-12-14T17:41:11	169.962	172.951	14.68
2021-12-14T17:41:12	170.08	173.036	14.68
2021-12-14T17:41:13	170.088	172.92	14.68
2021-12-14T17:41:14	170.096	172.99	14.68
2021-12-14T17:41:15	170.246	172.784	14.68
2021-12-14T17:41:16	170.125	172.823	14.68
2021-12-14T17:41:17	170.094	172.946	14.68
2021-12-14T17:41:18	170.198	172.827	14.68
2021-12-14T17:41:19	170.083	172.905	14.68
2021-12-14T17:41:20	170.205	173.051	14.68
2021-12-14T17:41:21	170.156	172.848	14.68
2021-12-14T17:41:22	170.028	172.941	14.68
2021-12-14T17:41:23	170.294	173.015	14.68
2021-12-14T17:41:24	170.203	172.775	14.68
2021-12-14T17:41:25	170.041	172.708	14.45
2021-12-14T17:41:26	170.155	173.092	14.45
2021-12-14T17:41:27	170.109	172.769	14.45
2021-12-14T17:41:28	170.014	172.764	14.45
2021-12-14T17:41:29	170.18	172.762	14.45
2021-12-14T17:41:30	170.114	172.642	14.45
2021-12-14T17:41:31	170.133	172.531	14.45
2021-12-14T17:41:32	170.184	172.642	14.45
2021-12-14T17:41:33	170.17	172.628	14.45
2021-12-14T17:41:34	170.118	172.8	14.45
2021-12-14T17:41:35	169.972	172.399	14.45
2021-12-14T17:41:36	170.146	172.569	14.45

2021-12-14T17:41:37	170.179	172.79	14.45
2021-12-14T17:41:38	169.923	172.479	14.45
2021-12-14T17:41:39	170.142	172.582	14.45
2021-12-14T17:41:40	170.185	172.538	14.45
2021-12-14T17:41:41	169.934	172.616	14.45
2021-12-14T17:41:42	170.246	172.397	14.45
2021-12-14T17:41:43	170.185	172.587	14.45
2021-12-14T17:41:44	170.038	172.814	14.45
2021-12-14T17:41:45	170.228	172.718	14.45
2021-12-14T17:41:46	170.158	172.839	14.45
2021-12-14T17:41:47	169.975	172.825	14.45
2021-12-14T17:41:48	170.123	172.921	14.45
2021-12-14T17:41:49	170.086	173.061	14.45
2021-12-14T17:41:50	169.99	172.877	15.4
2021-12-14T17:41:51	170.04	172.91	15.4
2021-12-14T17:41:52	170.11	172.878	15.4
2021-12-14T17:41:53	169.939	172.477	15.4
2021-12-14T17:41:54	169.947	172.776	15.4
2021-12-14T17:41:55	170.139	172.864	15.4
2021-12-14T17:41:56	169.979	172.602	15.4
2021-12-14T17:41:57	170.096	172.656	15.4
2021-12-14T17:41:58	170.098	172.796	15.4
2021-12-14T17:41:59	169.976	172.687	15.4
2021-12-14T17:42:00	170.088	172.568	15.4
2021-12-14T17:42:01	170.097	172.95	15.4
2021-12-14T17:42:02	170.002	172.845	15.4
2021-12-14T17:42:03	170.047	172.859	15.4
2021-12-14T17:42:04	170.011	172.788	15.4
2021-12-14T17:42:05	170.104	173.247	15.4
2021-12-14T17:42:06	170.235	172.871	15.4
2021-12-14T17:42:07	170.112	173.097	15.4
2021-12-14T17:42:08	170.238	172.998	15.4
2021-12-14T17:42:09	170.215	173.179	15.4
2021-12-14T17:42:10	170.12	173.088	15.4
2021-12-14T17:42:11	170.161	172.94	15.4
2021-12-14T17:42:12	170.218	173.401	15.4
2021-12-14T17:42:13	170.095	173.062	15.4
2021-12-14T17:42:14	170.148	173.029	15.4
2021-12-14T17:42:15	170.088	173.222	15.99
2021-12-14T17:42:16	170.176	173.188	15.99
2021-12-14T17:42:17	170.15	172.857	15.99
2021-12-14T17:42:18	169.889	173.033	15.99
2021-12-14T17:42:19	170.042	173.165	15.99
2021-12-14T17:42:20	170.065	173.022	15.99
2021-12-14T17:42:21	169.865	173.164	15.99

2021-12-14T17:42:22	170.157	173.157	15.99
2021-12-14T17:42:23	169.919	173.047	15.99
2021-12-14T17:42:24	169.881	172.937	15.99
2021-12-14T17:42:25	170.074	173.157	15.99
2021-12-14T17:42:26	169.9	173.405	15.99
2021-12-14T17:42:27	169.974	172.983	15.99
2021-12-14T17:42:28	170.072	173.181	15.99
2021-12-14T17:42:29	169.929	173.166	15.99
2021-12-14T17:42:30	170.128	173.092	15.99
2021-12-14T17:42:31	170.105	173.165	15.99
2021-12-14T17:42:32	170.155	172.958	15.99
2021-12-14T17:42:33	170.189	173.046	15.99
2021-12-14T17:42:34	170.115	173.206	15.99
2021-12-14T17:42:35	170.211	173.108	15.99
2021-12-14T17:42:36	170.222	172.984	15.99
2021-12-14T17:42:37	170.151	173.312	15.99
2021-12-14T17:42:38	170.245	173.016	15.99
2021-12-14T17:42:39	170.354	173.016	15.99
2021-12-14T17:42:40	170.213	173.064	15.1
2021-12-14T17:42:41	170.27	173.127	15.1
2021-12-14T17:42:42	170.364	173.019	15.1
2021-12-14T17:42:43	170.186	172.921	15.1
2021-12-14T17:42:44	170.113	172.996	15.1
2021-12-14T17:42:45	170.205	172.977	15.1
2021-12-14T17:42:46	170.233	173.048	15.1
2021-12-14T17:42:47	170.103	173.211	15.1
2021-12-14T17:42:48	170.219	173.143	15.1
2021-12-14T17:42:49	170.219	173.161	15.1
2021-12-14T17:42:50	170.07	173.108	15.1
2021-12-14T17:42:51	170.206	173.013	15.1
2021-12-14T17:42:52	170.069	173.343	15.1
2021-12-14T17:42:53	170.073	173.122	15.1
2021-12-14T17:42:54	170.22	173.068	15.1
2021-12-14T17:42:55	170.039	173.233	15.1
2021-12-14T17:42:56	169.934	173.116	15.1
2021-12-14T17:42:57	170.211	173.07	15.1
2021-12-14T17:42:58	170.021	173.107	15.1
2021-12-14T17:42:59	170	173.184	15.1
2021-12-14T17:43:00	170.204	173.091	15.1
2021-12-14T17:43:01	170.017	172.848	15.1
2021-12-14T17:43:02	170.096	173.038	15.1
2021-12-14T17:43:03	170.169	172.871	15.1
2021-12-14T17:43:04	170.096	172.965	15.1
2021-12-14T17:43:05	170.137	172.851	15.27
2021-12-14T17:43:06	170.136	172.688	15.27

2021-12-14T17:43:07	170.263	172.46	15.27
2021-12-14T17:43:08	170.158	172.39	15.27
2021-12-14T17:43:09	170.124	172.191	15.27
2021-12-14T17:43:10	170.245	172.12	15.27
2021-12-14T17:43:11	170.051	172.238	15.27
2021-12-14T17:43:12	170.244	172.213	15.27
2021-12-14T17:43:13	170.289	172.52	15.27
2021-12-14T17:43:14	170.082	172.417	15.27
2021-12-14T17:43:15	170.197	172.304	15.27
2021-12-14T17:43:16	170.141	172.638	15.27
2021-12-14T17:43:17	170.002	172.815	15.27
2021-12-14T17:43:18	170.209	172.571	15.27
2021-12-14T17:43:19	170.045	172.764	15.27
2021-12-14T17:43:20	169.996	173.082	15.27
2021-12-14T17:43:21	170.095	172.967	15.27
2021-12-14T17:43:22	169.988	173.112	15.27
2021-12-14T17:43:23	170.018	173.251	15.27
2021-12-14T17:43:24	170.012	173.084	15.27
2021-12-14T17:43:25	170.005	173.031	15.27
2021-12-14T17:43:26	170.114	173.206	15.27
2021-12-14T17:43:27	170.043	173.038	15.27
2021-12-14T17:43:28	170.215	173.049	15.27
2021-12-14T17:43:29	170.238	172.961	15.27
2021-12-14T17:43:30	170.014	173.119	16.34
2021-12-14T17:43:31	170.273	173.132	16.34
2021-12-14T17:43:32	170.252	172.712	16.34
2021-12-14T17:43:33	170.163	172.742	16.34
2021-12-14T17:43:34	170.319	172.738	16.34
2021-12-14T17:43:35	170.332	172.406	16.34
2021-12-14T17:43:36	170.288	172.444	16.34
2021-12-14T17:43:37	170.411	172.367	16.34
2021-12-14T17:43:38	170.201	172.398	16.34
2021-12-14T17:43:39	170.325	172.429	16.34
2021-12-14T17:43:40	170.359	172.496	16.34
2021-12-14T17:43:41	170.235	172.576	16.34
2021-12-14T17:43:42	170.405	172.363	16.34
2021-12-14T17:43:43	170.243	172.323	16.34
2021-12-14T17:43:44	170.268	172.024	16.34
2021-12-14T17:43:45	170.331	171.973	16.34
2021-12-14T17:43:46	170.296	171.906	16.34
2021-12-14T17:43:47	170.335	171.798	16.34
2021-12-14T17:43:48	170.424	172.402	16.34
2021-12-14T17:43:49	170.251	172.142	16.34
2021-12-14T17:43:50	170.264	172.323	16.34
2021-12-14T17:43:51	170.379	172.384	16.34

2021-12-14T17:43:52	170.276	172.533	16.34
2021-12-14T17:43:53	170.421	172.528	16.34
2021-12-14T17:43:54	170.341	172.602	16.34
2021-12-14T17:43:55	170.317	172.775	16.93
2021-12-14T17:43:56	170.428	172.774	16.93
2021-12-14T17:43:57	170.368	172.759	16.93
2021-12-14T17:43:58	170.368	172.931	16.93
2021-12-14T17:43:59	170.412	173.203	16.93
2021-12-14T17:44:00	170.409	173.051	16.93
2021-12-14T17:44:01	170.393	173.239	16.93
2021-12-14T17:44:02	170.46	173.122	16.93
2021-12-14T17:44:03	170.476	173.304	16.93
2021-12-14T17:44:04	170.446	173.089	16.93
2021-12-14T17:44:05	170.566	173.241	16.93
2021-12-14T17:44:06	170.496	173.214	16.93
2021-12-14T17:44:07	170.461	173.107	16.93
2021-12-14T17:44:08	170.582	173.153	16.93
2021-12-14T17:44:09	170.48	173.173	16.93
2021-12-14T17:44:10	170.323	173.172	16.93
2021-12-14T17:44:11	170.484	173.192	16.93
2021-12-14T17:44:12	170.386	173.088	16.93
2021-12-14T17:44:13	170.345	173.118	16.93
2021-12-14T17:44:14	170.423	173.171	16.93
2021-12-14T17:44:15	170.403	173.282	16.93
2021-12-14T17:44:16	170.357	172.911	16.93
2021-12-14T17:44:17	170.374	173.299	16.93
2021-12-14T17:44:18	170.298	173.139	16.93
2021-12-14T17:44:19	170.328	173.122	16.93
2021-12-14T17:44:20	170.341	173.291	16.44
2021-12-14T17:44:21	170.338	173.224	16.44
2021-12-14T17:44:22	170.431	173.095	16.44
2021-12-14T17:44:23	170.341	172.988	16.44
2021-12-14T17:44:24	170.377	173.114	16.44
2021-12-14T17:44:25	170.462	172.996	16.44
2021-12-14T17:44:26	170.296	173.033	16.44
2021-12-14T17:44:27	170.465	172.986	16.44
2021-12-14T17:44:28	170.492	172.751	16.44
2021-12-14T17:44:29	170.335	172.625	16.44
2021-12-14T17:44:30	170.585	172.993	16.44
2021-12-14T17:44:31	170.569	172.698	16.44
2021-12-14T17:44:32	170.423	172.92	16.44
2021-12-14T17:44:33	170.591	172.764	16.44
2021-12-14T17:44:34	170.605	172.801	16.44
2021-12-14T17:44:35	170.353	172.942	16.44
2021-12-14T17:44:36	170.538	172.903	16.44

2021-12-14T17:44:37	170.572	173.123	16.44
2021-12-14T17:44:38	170.478	173.217	16.44
2021-12-14T17:44:39	170.368	173.28	16.44
2021-12-14T17:44:40	170.551	173.31	16.44
2021-12-14T17:44:41	170.487	173.138	16.44
2021-12-14T17:44:42	170.309	173.185	16.44
2021-12-14T17:44:43	170.441	173.073	16.44
2021-12-14T17:44:44	170.305	173.192	16.44
2021-12-14T17:44:45	170.28	173.263	16.74
2021-12-14T17:44:46	170.427	173.333	16.74
2021-12-14T17:44:47	170.265	173.072	16.74
2021-12-14T17:44:48	170.18	173.175	16.74
2021-12-14T17:44:49	170.343	173.065	16.74
2021-12-14T17:44:50	170.254	173.221	16.74
2021-12-14T17:44:51	170.243	173.172	16.74
2021-12-14T17:44:52	170.273	173.122	16.74
2021-12-14T17:44:53	170.225	172.974	16.74
2021-12-14T17:44:54	170.235	173.066	16.74
2021-12-14T17:44:55	170.353	173.34	16.74
2021-12-14T17:44:56	170.329	173.226	16.74
2021-12-14T17:44:57	170.358	172.939	16.74
2021-12-14T17:44:58	170.337	173.199	16.74
2021-12-14T17:44:59	170.407	173.237	16.74
2021-12-14T17:45:00	170.399	172.975	16.74
2021-12-14T17:45:01	170.271	173.218	16.74
2021-12-14T17:45:02	170.4	173.31	16.74
2021-12-14T17:45:03	170.389	173.21	16.74
2021-12-14T17:45:04	170.491	173.032	16.74
2021-12-14T17:45:05	170.557	173.356	16.74
2021-12-14T17:45:06	170.297	173.149	16.74
2021-12-14T17:45:07	170.448	173.141	16.74
2021-12-14T17:45:08	170.48	173.178	16.74
2021-12-14T17:45:09	170.265	173.061	16.74
2021-12-14T17:45:10	170.397	173.189	17.24
2021-12-14T17:45:11	170.305	173.198	17.24
2021-12-14T17:45:12	170.253	173.31	17.24
2021-12-14T17:45:13	170.512	173.141	17.24
2021-12-14T17:45:14	170.341	173.201	17.24
2021-12-14T17:45:15	170.268	173.027	17.24
2021-12-14T17:45:16	170.487	173.159	17.24
2021-12-14T17:45:17	170.308	173.513	17.24
2021-12-14T17:45:18	170.288	173.407	17.24
2021-12-14T17:45:19	170.39	173.071	17.24
2021-12-14T17:45:20	170.228	173.227	17.24
2021-12-14T17:45:21	170.374	173.29	17.24

2021-12-14T17:45:22	170.373	173.205	17.24
2021-12-14T17:45:23	170.454	173.004	17.24
2021-12-14T17:45:24	170.331	173.345	17.24
2021-12-14T17:45:25	170.357	173.191	17.24
2021-12-14T17:45:26	170.454	172.984	17.24
2021-12-14T17:45:27	170.409	173.289	17.24
2021-12-14T17:45:28	170.283	173.181	17.24
2021-12-14T17:45:29	170.422	172.924	17.24
2021-12-14T17:45:30	170.277	173.007	17.24
2021-12-14T17:45:31	170.295	173.087	17.24
2021-12-14T17:45:32	170.352	173.171	17.24
2021-12-14T17:45:33	170.181	172.996	17.24
2021-12-14T17:45:34	170.209	173.155	17.24
2021-12-14T17:45:35	170.348	173.047	17.21
2021-12-14T17:45:36	170.156	173.191	17.21
2021-12-14T17:45:37	170.248	173.229	17.21
2021-12-14T17:45:38	170.131	172.899	17.21
2021-12-14T17:45:39	170.16	173.15	17.21
2021-12-14T17:45:40	170.241	173.147	17.21
2021-12-14T17:45:41	170.078	173.12	17.21
2021-12-14T17:45:42	170.195	173.331	17.21
2021-12-14T17:45:43	170.214	173.273	17.21
2021-12-14T17:45:44	169.999	173.088	17.21
2021-12-14T17:45:45	170.197	173.029	17.21
2021-12-14T17:45:46	170.21	172.982	17.21
2021-12-14T17:45:47	170.136	172.917	17.21
2021-12-14T17:45:48	170.225	172.858	17.21
2021-12-14T17:45:49	170.179	173.001	17.21
2021-12-14T17:45:50	170.184	173.111	17.21
2021-12-14T17:45:51	170.379	173.271	17.21
2021-12-14T17:45:52	170.204	173.292	17.21
2021-12-14T17:45:53	170.345	173.35	17.21
2021-12-14T17:45:54	170.419	173.013	17.21
2021-12-14T17:45:55	170.425	173.307	17.21
2021-12-14T17:45:56	170.421	173.265	17.21
2021-12-14T17:45:57	170.383	173.199	17.21
2021-12-14T17:45:58	170.454	173.334	17.21
2021-12-14T17:45:59	170.386	173.254	17.21
2021-12-14T17:46:00	170.41	172.983	17.37
2021-12-14T17:46:01	170.459	173.426	17.37
2021-12-14T17:46:02	170.442	173.283	17.37
2021-12-14T17:46:03	170.409	172.963	17.37
2021-12-14T17:46:04	170.466	173.226	17.37
2021-12-14T17:46:05	170.282	173.295	17.37
2021-12-14T17:46:06	170.279	173.146	17.37

2021-12-14T17:46:07	170.395	173.207	17.37
2021-12-14T17:46:08	170.218	173.325	17.37
2021-12-14T17:46:09	170.2	172.988	17.37
2021-12-14T17:46:10	170.218	173.244	17.37
2021-12-14T17:46:11	170.153	173.34	17.37
2021-12-14T17:46:12	170.131	173.029	17.37
2021-12-14T17:46:13	170.121	173.208	17.37
2021-12-14T17:46:14	170.153	173.418	17.37
2021-12-14T17:46:15	170.126	173.235	17.37
2021-12-14T17:46:16	170.148	173.076	17.37
2021-12-14T17:46:17	170.175	173.289	17.37
2021-12-14T17:46:18	170.169	173.147	17.37
2021-12-14T17:46:19	170.243	173.111	17.37
2021-12-14T17:46:20	170.215	173.076	17.37
2021-12-14T17:46:21	170.113	173.155	17.37
2021-12-14T17:46:22	170.405	173.124	17.37
2021-12-14T17:46:23	170.366	173.153	17.37
2021-12-14T17:46:24	170.288	173.379	17.37
2021-12-14T17:46:25	170.519	173.106	17.16
2021-12-14T17:46:26	170.309	173.107	17.16
2021-12-14T17:46:27	170.361	173.274	17.16
2021-12-14T17:46:28	170.657	173.27	17.16
2021-12-14T17:46:29	170.349	173.034	17.16
2021-12-14T17:46:30	170.462	173.199	17.16
2021-12-14T17:46:31	170.546	173.312	17.16
2021-12-14T17:46:32	170.38	173.17	17.16
2021-12-14T17:46:33	170.525	173.116	17.16
2021-12-14T17:46:34	170.4	173.2	17.16
2021-12-14T17:46:35	170.417	172.789	17.16
2021-12-14T17:46:36	170.447	173.009	17.16
2021-12-14T17:46:37	170.354	173.031	17.16
2021-12-14T17:46:38	170.413	173.024	17.16
2021-12-14T17:46:39	170.422	173.037	17.16
2021-12-14T17:46:40	170.359	172.91	17.16
2021-12-14T17:46:41	170.451	172.841	17.16
2021-12-14T17:46:42	170.341	172.716	17.16
2021-12-14T17:46:43	170.307	173.002	17.16
2021-12-14T17:46:44	170.455	172.768	17.16
2021-12-14T17:46:45	170.185	172.711	17.16
2021-12-14T17:46:46	170.332	172.828	17.16
2021-12-14T17:46:47	170.288	172.165	17.16
2021-12-14T17:46:48	170.208	172.334	17.16
2021-12-14T17:46:49	170.148	172.576	17.16
2021-12-14T17:46:50	170.285	172.393	16.88
2021-12-14T17:46:51	170.191	172.252	16.88

2021-12-14T17:46:52	170.24	172.745	16.88
2021-12-14T17:46:53	170.267	172.71	16.88
2021-12-14T17:46:54	170.201	172.531	16.88
2021-12-14T17:46:55	170.146	172.531	16.88
2021-12-14T17:46:56	170.25	172.462	16.88
2021-12-14T17:46:57	170.291	172.303	16.88
2021-12-14T17:46:58	170.146	172.361	16.88
2021-12-14T17:46:59	170.183	172.47	16.88
2021-12-14T17:47:00	170.253	172.624	16.88
2021-12-14T17:47:01	170.118	172.469	16.88
2021-12-14T17:47:02	170.199	172.319	16.88
2021-12-14T17:47:03	170.16	172.51	16.88
2021-12-14T17:47:04	169.977	172.167	16.88
2021-12-14T17:47:05	170.269	172.268	16.88
2021-12-14T17:47:06	170.109	172.423	16.88
2021-12-14T17:47:07	169.98	172.546	16.88
2021-12-14T17:47:08	170.263	172.327	16.88
2021-12-14T17:47:09	170.052	172.352	16.88
2021-12-14T17:47:10	170.071	172.302	16.88
2021-12-14T17:47:11	170.182	172.407	16.88
2021-12-14T17:47:12	170.034	172.086	16.88
2021-12-14T17:47:13	170.082	171.995	16.88
2021-12-14T17:47:14	170.132	172.1	16.88
2021-12-14T17:47:15	170.166	172.121	16.19
2021-12-14T17:47:16	170.105	171.917	16.19
2021-12-14T17:47:17	170.087	172.374	16.19
2021-12-14T17:47:18	170.244	172.228	16.19
2021-12-14T17:47:19	170.177	172.337	16.19
2021-12-14T17:47:20	170.052	172.445	16.19
2021-12-14T17:47:21	170.23	172.394	16.19
2021-12-14T17:47:22	170.124	172.385	16.19
2021-12-14T17:47:23	170.16	172.422	16.19
2021-12-14T17:47:24	170.274	172.449	16.19
2021-12-14T17:47:25	170.106	172.335	16.19
2021-12-14T17:47:26	170.098	172.118	16.19
2021-12-14T17:47:27	170.25	172.52	16.19
2021-12-14T17:47:28	170.179	172.56	16.19
2021-12-14T17:47:29	170.195	172.374	16.19
2021-12-14T17:47:30	170.161	172.5	16.19
2021-12-14T17:47:31	170.206	172.614	16.19
2021-12-14T17:47:32	170.254	172.3	16.19
2021-12-14T17:47:33	170.074	172.222	16.19
2021-12-14T17:47:34	170.102	172.332	16.19
2021-12-14T17:47:35	170.252	172.161	16.19
2021-12-14T17:47:36	170.181	172.322	16.19

2021-12-14T17:47:37	170.214	172.302	16.19
2021-12-14T17:47:38	170.254	172.103	16.19
2021-12-14T17:47:39	170.116	172.294	16.19
2021-12-14T17:47:40	170.213	172.122	16.12
2021-12-14T17:47:41	170.171	171.95	16.12
2021-12-14T17:47:42	170.234	172.206	16.12
2021-12-14T17:47:43	170.161	171.924	16.12
2021-12-14T17:47:44	170.178	172.323	16.12
2021-12-14T17:47:45	170.229	172.294	16.12
2021-12-14T17:47:46	170.233	172.369	16.12
2021-12-14T17:47:47	170.221	172.181	16.12
2021-12-14T17:47:48	170.253	172.407	16.12
2021-12-14T17:47:49	170.161	172.344	16.12
2021-12-14T17:47:50	170.265	172.217	16.12
2021-12-14T17:47:51	170.249	172.43	16.12
2021-12-14T17:47:52	170.063	172.46	16.12
2021-12-14T17:47:53	170.242	172.476	16.12
2021-12-14T17:47:54	170.156	172.451	16.12
2021-12-14T17:47:55	170.208	172.44	16.12
2021-12-14T17:47:56	170.284	172.725	16.12
2021-12-14T17:47:57	170.039	172.853	16.12
2021-12-14T17:47:58	170.221	172.522	16.12
2021-12-14T17:47:59	170.288	172.893	16.12
2021-12-14T17:48:00	169.998	172.709	16.12
2021-12-14T17:48:01	170.138	172.65	16.12
2021-12-14T17:48:02	170.084	172.755	16.12
2021-12-14T17:48:03	169.992	172.911	16.12
2021-12-14T17:48:04	170.245	172.636	16.12
2021-12-14T17:48:05	170.019	172.666	15.71
2021-12-14T17:48:06	169.925	172.828	15.71
2021-12-14T17:48:07	170.125	172.693	15.71
2021-12-14T17:48:08	170.118	172.823	15.71
2021-12-14T17:48:09	169.972	172.841	15.71
2021-12-14T17:48:10	170.017	172.816	15.71
2021-12-14T17:48:11	170.024	172.552	15.71
2021-12-14T17:48:12	170.045	172.284	15.71
2021-12-14T17:48:13	170.1	171.948	15.71
2021-12-14T17:48:14	170.05	171.998	15.71
2021-12-14T17:48:15	170.039	171.783	15.71
2021-12-14T17:48:16	170.012	171.956	15.71
2021-12-14T17:48:17	170.239	171.821	15.71
2021-12-14T17:48:18	170.03	171.837	15.71
2021-12-14T17:48:19	169.962	171.473	15.71
2021-12-14T17:48:20	170.105	171.413	15.71
2021-12-14T17:48:21	169.985	171.63	15.71

2021-12-14T17:48:22	169.954	171.348	15.71
2021-12-14T17:48:23	170.044	171.247	15.71
2021-12-14T17:48:24	169.957	171.533	15.71
2021-12-14T17:48:25	169.967	171.486	15.71
2021-12-14T17:48:26	169.998	171.371	15.71
2021-12-14T17:48:27	169.978	171.654	15.71
2021-12-14T17:48:28	169.818	171.787	15.71
2021-12-14T17:48:29	169.919	171.686	15.71
2021-12-14T17:48:30	169.974	171.831	16.16
2021-12-14T17:48:31	169.858	172.091	16.16
2021-12-14T17:48:32	169.739	172.039	16.16
2021-12-14T17:48:33	170.015	171.976	16.16
2021-12-14T17:48:34	169.778	172.485	16.16
2021-12-14T17:48:35	169.79	172.389	16.16
2021-12-14T17:48:36	169.984	172.509	16.16
2021-12-14T17:48:37	169.885	172.811	16.16
2021-12-14T17:48:38	169.928	172.572	16.16
2021-12-14T17:48:39	169.982	172.64	16.16
2021-12-14T17:48:40	169.923	172.827	16.16
2021-12-14T17:48:41	169.926	173.085	16.16
2021-12-14T17:48:42	170.047	173.212	16.16
2021-12-14T17:48:43	170.017	173.198	16.16
2021-12-14T17:48:44	170.032	173.118	16.16
2021-12-14T17:48:45	170.174	173.329	16.16
2021-12-14T17:48:46	170.089	173.146	16.16
2021-12-14T17:48:47	170.173	173.135	16.16
2021-12-14T17:48:48	170.146	173.191	16.16
2021-12-14T17:48:49	170.214	173.324	16.16
2021-12-14T17:48:50	170.206	173.333	16.16
2021-12-14T17:48:51	170.161	173.144	16.16
2021-12-14T17:48:52	170.27	173.177	16.16
2021-12-14T17:48:53	170.288	173.003	16.16
2021-12-14T17:48:54	170.219	172.926	16.16
2021-12-14T17:48:55	170.257	173.166	15.85
2021-12-14T17:48:56	170.161	173.402	15.85
2021-12-14T17:48:57	170.224	172.973	15.85
2021-12-14T17:48:58	170.296	173.242	15.85
2021-12-14T17:48:59	170.22	173.376	15.85
2021-12-14T17:49:00	170.221	173.123	15.85
2021-12-14T17:49:01	170.159	173.152	15.85
2021-12-14T17:49:02	170.163	173.318	15.85
2021-12-14T17:49:03	170.244	173.013	15.85
2021-12-14T17:49:04	170.172	173.329	15.85
2021-12-14T17:49:05	170.153	173.29	15.85
2021-12-14T17:49:06	170.16	172.884	15.85

2021-12-14T17:49:07	170.047	173.3	15.85
2021-12-14T17:49:08	170.093	173.332	15.85
2021-12-14T17:49:09	170.068	173.111	15.85
2021-12-14T17:49:10	170.152	173.196	15.85
2021-12-14T17:49:11	169.995	173.019	15.85
2021-12-14T17:49:12	170.067	172.912	15.85
2021-12-14T17:49:13	170.216	173.021	15.85
2021-12-14T17:49:14	169.977	172.85	15.85
2021-12-14T17:49:15	169.98	172.71	15.85
2021-12-14T17:49:16	170.195	172.641	15.85
2021-12-14T17:49:17	169.956	172.848	15.85
2021-12-14T17:49:18	170.125	172.702	15.85
2021-12-14T17:49:19	170.189	172.527	15.85
2021-12-14T17:49:20	169.946	172.691	15.44
2021-12-14T17:49:21	170.106	172.625	15.44
2021-12-14T17:49:22	170.151	172.581	15.44
2021-12-14T17:49:23	169.938	172.289	15.44
2021-12-14T17:49:24	170.131	172.41	15.44
2021-12-14T17:49:25	170.027	172.349	15.44
2021-12-14T17:49:26	169.99	172.207	15.44
2021-12-14T17:49:27	170.082	172.478	15.44
2021-12-14T17:49:28	170.011	172.63	15.44
2021-12-14T17:49:29	170.017	172.59	15.44
2021-12-14T17:49:30	170.04	172.58	15.44
2021-12-14T17:49:31	169.977	172.666	15.44
2021-12-14T17:49:32	170.06	172.343	15.44
2021-12-14T17:49:33	170.031	172.158	15.44
2021-12-14T17:49:34	169.96	172.321	15.44
2021-12-14T17:49:35	170.086	171.973	15.44
2021-12-14T17:49:36	169.949	171.767	15.44
2021-12-14T17:49:37	169.99	172.12	15.44
2021-12-14T17:49:38	170.043	172.185	15.44
2021-12-14T17:49:39	169.954	171.919	15.44
2021-12-14T17:49:40	170.005	172.472	15.44
2021-12-14T17:49:41	170.022	172.68	15.44
2021-12-14T17:49:42	169.984	172.591	15.44
2021-12-14T17:49:43	170.005	172.881	15.44
2021-12-14T17:49:44	169.999	172.907	15.44
2021-12-14T17:49:45	170.049	172.8	15.05
2021-12-14T17:49:46	170.038	172.966	15.05
2021-12-14T17:49:47	170.021	173.012	15.05
2021-12-14T17:49:48	170.065	173.241	15.05
2021-12-14T17:49:49	169.994	173.394	15.05
2021-12-14T17:49:50	170.025	172.998	15.05
2021-12-14T17:49:51	170.151	173.107	15.05

2021-12-14T17:49:52	170.012	173.467	15.05
2021-12-14T17:49:53	170.025	173.077	15.05
2021-12-14T17:49:54	170.037	173.013	15.05
2021-12-14T17:49:55	169.938	173.362	15.05
2021-12-14T17:49:56	170.021	173.301	15.05
2021-12-14T17:49:57	170.037	173.114	15.05
2021-12-14T17:49:58	169.984	173.232	15.05
2021-12-14T17:49:59	169.974	173.26	15.05
2021-12-14T17:50:00	169.987	173.175	15.05
2021-12-14T17:50:01	169.986	173.17	15.05
2021-12-14T17:50:02	169.965	173.052	15.05
2021-12-14T17:50:03	170.04	172.832	15.05
2021-12-14T17:50:04	170.1	172.855	15.05
2021-12-14T17:50:05	169.987	172.61	15.05
2021-12-14T17:50:06	170	172.185	15.05
2021-12-14T17:50:07	170.003	171.988	15.05
2021-12-14T17:50:08	170.097	171.979	15.05
2021-12-14T17:50:09	170.276	171.905	15.05
2021-12-14T17:50:10	170.211	171.994	15.1
2021-12-14T17:50:11	170.204	171.921	15.1
2021-12-14T17:50:12	170.305	172.055	15.1
2021-12-14T17:50:13	170.153	172.194	15.1
2021-12-14T17:50:14	170.113	172.378	15.1
2021-12-14T17:50:15	170.261	172.465	15.1
2021-12-14T17:50:16	170.201	172.707	15.1
2021-12-14T17:50:17	170.241	172.755	15.1
2021-12-14T17:50:18	170.296	172.921	15.1
2021-12-14T17:50:19	170.154	172.898	15.1
2021-12-14T17:50:20	170.205	172.829	15.1
2021-12-14T17:50:21	170.203	172.773	15.1
2021-12-14T17:50:22	170.163	172.668	15.1
2021-12-14T17:50:23	170.174	172.596	15.1
2021-12-14T17:50:24	170.087	172.809	15.1
2021-12-14T17:50:25	170.124	172.722	15.1
2021-12-14T17:50:26	170.178	172.701	15.1
2021-12-14T17:50:27	170.064	172.751	15.1
2021-12-14T17:50:28	170.2	172.709	15.1
2021-12-14T17:50:29	170.014	172.58	15.1
2021-12-14T17:50:30	170.1	172.672	15.1
2021-12-14T17:50:31	170.094	172.797	15.1
2021-12-14T17:50:32	169.902	172.692	15.1
2021-12-14T17:50:33	170.104	172.862	15.1
2021-12-14T17:50:34	170.189	172.793	15.1
2021-12-14T17:50:35	170.052	172.827	14.9
2021-12-14T17:50:36	170.211	172.953	14.9

2021-12-14T17:50:37	170.174	172.854	14.9
2021-12-14T17:50:38	170.14	172.964	14.9
2021-12-14T17:50:39	170.279	172.844	14.9
2021-12-14T17:50:40	170.175	172.913	14.9
2021-12-14T17:50:41	170.242	172.751	14.9
2021-12-14T17:50:42	170.336	172.596	14.9
2021-12-14T17:50:43	170.17	172.698	14.9
2021-12-14T17:50:44	170.353	172.689	14.9
2021-12-14T17:50:45	170.331	172.528	14.9
2021-12-14T17:50:46	170.284	172.55	14.9
2021-12-14T17:50:47	170.357	172.553	14.9
2021-12-14T17:50:48	170.297	172.583	14.9
2021-12-14T17:50:49	170.403	172.653	14.9
2021-12-14T17:50:50	170.271	172.583	14.9
2021-12-14T17:50:51	170.119	172.552	14.9
2021-12-14T17:50:52	170.241	172.645	14.9
2021-12-14T17:50:53	170.216	172.724	14.9
2021-12-14T17:50:54	170.073	172.581	14.9
2021-12-14T17:50:55	170.271	172.883	14.9
2021-12-14T17:50:56	170.159	172.873	14.9
2021-12-14T17:50:57	170.094	172.9	14.9
2021-12-14T17:50:58	170.281	172.88	14.9
2021-12-14T17:50:59	170.112	172.97	14.9
2021-12-14T17:51:00	170.036	173.26	15.34
2021-12-14T17:51:01	170.243	173.004	15.34
2021-12-14T17:51:02	170.124	173.215	15.34
2021-12-14T17:51:03	170.163	173.197	15.34
2021-12-14T17:51:04	170.15	172.992	15.34
2021-12-14T17:51:05	170.154	173.253	15.34
2021-12-14T17:51:06	170.108	173.173	15.34
2021-12-14T17:51:07	170.146	172.949	15.34
2021-12-14T17:51:08	170.254	173.263	15.34
2021-12-14T17:51:09	170.164	173.266	15.34
2021-12-14T17:51:10	170.151	173.014	15.34
2021-12-14T17:51:11	170.29	173.317	15.34
2021-12-14T17:51:12	170.25	173.236	15.34
2021-12-14T17:51:13	170.208	173.153	15.34
2021-12-14T17:51:14	170.302	173.032	15.34
2021-12-14T17:51:15	170.26	173.343	15.34
2021-12-14T17:51:16	170.284	173.2	15.34
2021-12-14T17:51:17	170.249	173.085	15.34
2021-12-14T17:51:18	170.283	173.029	15.34
2021-12-14T17:51:19	170.255	173.05	15.34
2021-12-14T17:51:20	170.194	173.177	15.34
2021-12-14T17:51:21	170.258	173.24	15.34

2021-12-14T17:51:22	170.175	173.1	15.34
2021-12-14T17:51:23	170.153	173.122	15.34
2021-12-14T17:51:24	170.217	173.262	15.34
2021-12-14T17:51:25	170.135	172.98	15.71
2021-12-14T17:51:26	170.122	173.026	15.71
2021-12-14T17:51:27	170.179	173.118	15.71
2021-12-14T17:51:28	170.032	172.905	15.71
2021-12-14T17:51:29	170.03	172.837	15.71
2021-12-14T17:51:30	170.02	172.828	15.71
2021-12-14T17:51:31	170.004	172.861	15.71
2021-12-14T17:51:32	170.012	172.756	15.71
2021-12-14T17:51:33	170.055	172.985	15.71
2021-12-14T17:51:34	170.006	173.156	15.71
2021-12-14T17:51:35	170.066	172.92	15.71
2021-12-14T17:51:36	169.999	172.962	15.71
2021-12-14T17:51:37	170.025	173.115	15.71
2021-12-14T17:51:38	170.083	172.874	15.71
2021-12-14T17:51:39	169.87	172.838	15.71
2021-12-14T17:51:40	170.063	172.966	15.71
2021-12-14T17:51:41	169.97	173.009	15.71
2021-12-14T17:51:42	169.858	172.976	15.71
2021-12-14T17:51:43	170.06	173.315	15.71
2021-12-14T17:51:44	169.948	173.068	15.71
2021-12-14T17:51:45	169.877	172.888	15.71
2021-12-14T17:51:46	170.033	173.432	15.71
2021-12-14T17:51:47	169.916	173.105	15.71
2021-12-14T17:51:48	169.916	173.224	15.71
2021-12-14T17:51:49	169.987	173.319	15.71
2021-12-14T17:51:50	169.862	173.262	15.44
2021-12-14T17:51:51	169.987	173.058	15.44
2021-12-14T17:51:52	169.918	173.189	15.44
2021-12-14T17:51:53	169.859	173.293	15.44
2021-12-14T17:51:54	170.003	173.115	15.44
2021-12-14T17:51:55	170.017	173.087	15.44
2021-12-14T17:51:56	169.985	173.142	15.44
2021-12-14T17:51:57	169.984	172.989	15.44
2021-12-14T17:51:58	169.965	173.142	15.44
2021-12-14T17:51:59	170.011	173.234	15.44
2021-12-14T17:52:00	169.977	173.143	15.44
2021-12-14T17:52:01	170.091	173.301	15.44
2021-12-14T17:52:02	170.007	173.242	15.44
2021-12-14T17:52:03	169.97	172.966	15.44
2021-12-14T17:52:04	170.129	173.403	15.44
2021-12-14T17:52:05	169.955	173.17	15.44
2021-12-14T17:52:06	170.002	173.102	15.44

2021-12-14T17:52:07	170.108	173.157	15.44
2021-12-14T17:52:08	169.97	173.458	15.44
2021-12-14T17:52:09	169.988	173.157	15.44
2021-12-14T17:52:10	170.037	173.053	15.44
2021-12-14T17:52:11	169.853	173.365	15.44
2021-12-14T17:52:12	169.949	173.2	15.44