

INFORME FINAL DE PRUEBAS INF 0347 – 2019 (REV 00)

Pruebas de Potencia Máxima Central Teno GAS 50

Cliente



ESTADO DEL DOCUMENTO				
Revisión	Fecha	Observaciones	Elaboró	Revisó
00	30.12.2019	Para revisión por parte del Coordinador Eléctrico Nacional	MNK	JPD

INDICE GENERAL

INTRODUCCIÓN	3
RESUMEN	3
RESPONSABILIDADES DEL PERSONAL INTERVINIENTE	3
CARACTERISTICAS DE LAS UNIDADES BAJO PRUEBA	4
CONDICIONES DE PRUEBA	4
EJECUCIÓN DE LA PRUEBA	5
CONDICIONES PARTICULARES	6
RESULTADOS DE LA PRUEBA	6
NORMAS APLICABLES	8
ANEXOS	8

1. INTRODUCCIÓN

El presente documento describe el procedimiento seguido para la prueba de potencia máxima de las 26 unidades pertenecientes a la Central Teno GAS 50 con combustible GLP, ubicada en la localidad de Teno, Región del Maule, Chile.

La prueba se llevó a cabo para dar cumplimiento al Anexo “Pruebas de Potencia Máxima en Unidades Generadoras” perteneciente a la norma técnica de seguridad y calidad del servicio (NTSyCS).

2. RESUMEN

La ejecución de la prueba de potencia máxima se realizó por nave, para lo cual se dispuso de cinco medidores externos **Bender PEM 735**, de los cuales cuatro fueron conectados directamente a los bornes de los generadores que fueron utilizados como muestra representativa de los demás, y el quinto fué conectado en el interruptor de salida del Tablero de Servicios Auxiliares.

La medición de la potencia neta se realizó del lado AT del transformador T1, con el medidor de facturación **Schneider ION 8650** existente.

Para obtener el valor final de potencia neta de la unidad se descontó la potencia medida en la salida del Tablero de Servicios Auxiliares.

Las mediciones se realizaron de a una nave por vez operando la planta de acuerdo al cuadro a continuación.

NAVE	GENERADOR	INSTALACION DE MEDIDOR	ESTADOS DE INTERRUPTORES DE NAVE			
			52CT4	52CT5	52CT6	52CT7
1	G1	X	CERRADO	ABIERTO	ABIERTO	ABIERTO
	G2	X				
	G3					
	G4					
	G5	X				
	G6					
	G7	X				
	G8					
2	G9	X	ABIERTO	CERRADO	ABIERTO	ABIERTO
	G10					
	G11	X				
	G12	X				
	G13					
	G14	X				
3	G15	X	ABIERTO	ABIERTO	CERRADO	ABIERTO
	G16					
	G17	X				
	G18	X				
	G19					
	G20	X				
4	G21	X	ABIERTO	ABIERTO	ABIERTO	CERRADO
	G22					
	G23	X				
	G24	X				
	G25					
	G26	X				

3. RESPONSABILIDADES DEL PERSONAL INTERVINIENTE

3.1. Representante de INERSA

El representante de INERSA dispuso del personal de mantenimiento y operaciones de la central, el cual brindó el apoyo necesario para la ejecución de la prueba, y se hizo responsable de las siguientes tareas:

- Conexión de los equipos de medición en los puntos definidos según el protocolo
- Realización de las maniobras necesarias de preparación, estabilización y operación de las unidades y naves a ensayar durante las pruebas
- Facilitó el ingreso y recolección de datos de los dispositivos de medición existentes

3.2. Experto técnico de DMA Energía

El experto técnico fué el responsable de la supervisión para llevar adelante las pruebas de acuerdo a lo siguiente:

- Operó los equipos de medición instalados para estos efectos.
- Compiló la información obtenida de todas las mediciones.
- Elaboró el acta de finalización de la prueba.
- Elaboró y entregó el informe final de la prueba al Coordinador Eléctrico Nacional.

4. CARACTERISTICAS DE LAS UNIDADES BAJO PRUEBA

Datos de placa de una Unidad Motor-Generador

Grupo Electrogeno		
Fabricante	Caterpillar	-
Num. de Serie	1558294	-
Año de Fabricación	08 / 2018	-
Potencia Nom.	COP 1720 / 2000	kW
Factor de Potencia Nom.	cos phi 1,0	-
Altitud max.de Instal.	421	m
Temperatura max.de Inst.	27	°C
Frecuencia Nominal	50	Hz
Voltaje Nominal	400	V
Corriente Nominal	2483 / 2887	A
Masa	18100 / 19850	kg
Tipo de Potencia	G2	-
Potencia Adicional para Regulación	5	%
Combustibles	Gas propano / Gas natura	

5. CONDICIONES DE PRUEBA

Antes del inicio de la prueba se verificó el cumplimiento de lo siguiente:

- El sistema SCADA estuvo disponible para la operación de la central en las condiciones requeridas por el coordinador
- No existieron alarmas relevantes
- Todas las protecciones estuvieron operativas
- El factor de potencia recomendado por el fabricante es 1, por lo tanto la prueba se realizó con ese ajuste
- El modo de control por frecuencia estaba deshabilitado
- La unidad estuvo operando bajo el modo control de carga

6. EJECUCIÓN DE LA PRUEBA

6.1. Verificaciones previas

Previo al inicio de las pruebas se verificó lo siguiente:

- Cumplimiento de las condiciones de prueba establecidas en el punto 5
- Lectura de todos los dispositivos de medición
- Sincronización horaria de los dispositivos de medición
- El sistema de adquisición de datos de la planta operaba correctamente
- Que todas las personas intervinientes se encuentren listas para el inicio de la prueba, con los EPP correspondientes.

6.2. Incremento de potencia y estabilización

Una vez que el operador puso en marcha todas las unidades de cada Nave en prueba, éste procedió a poner el ajuste de potencia al máximo disponible.

Una vez alcanzado esta potencia, se verificó que tanto las variables eléctricas como las variables termodinámicas se encontraban dentro de los límites seguros de operación.

Luego se dió comienzo al periodo de estabilización. Dicho período fue menor a dos horas; durante dicho período no fue necesario corregir ningún parámetro. El experto técnico registró el horario de inicio y finalización del periodo de estabilización.

6.3. Inicio de la prueba

Una vez finalizado el periodo de estabilización se dió inicio a la prueba, para lo cual se dejó constancia en el acta de prueba del horario exacto de inicio.

6.4. Periodo de prueba valido

La prueba tuvo una duración mínima de 05:00Hs durante las cuales las unidades cumplieron con los parámetros de estabilidad definidos por normas de acuerdo a la tabla a continuación. A los fines prácticos, para tener un control del proceso de prueba, se evaluaron esas 5 horas en 10 segmentos de datos de 30 minutos de duración cada uno.

PARAMETRO	VARIACIÓN ADMISIBLE	NORMA DE REFERENCIA
Potencia Eléctrica	± 3 [%]	ASME - PTC 17 - Reciprocating Internal Combustion Engines
Velocidad Rotacional	$\pm 1 / \pm 10$ [%] / [rpm]	
Temperatura de Aire de Admisión	± 2 [°C]	ISO 1550 : 2016 - Internal combustion engines - Determination and method for the measurement of engine power - General requirements
Temperatura del Refrigerante	± 2 [°C]	

6.5. Tasa de muestreo de los parámetros

Durante todo el periodo de prueba se registraron todos los parámetros cada un minuto, excepto la potencia activa que se tomó cada 1 segundo.

6.6. Detalle de la toma de muestras de parámetros

En la tabla a continuación se detalla la forma en que se tomaron los datos de los parámetros durante el periodo de prueba.

DETALLE DE MEDICIÓN Y ADQUISICIÓN DE DATOS					
Parámetro	Punto de Medición	Equipo a Utilizar	Unidad de Medida	Registro	Tasa de Muestreo
Caudal de combustible	Ingreso de gas para sistema alimentacion unidad	Micro Motion Serie "R"	[kg/h]	Digital	1 min
Caudal de combustible de los vaporizadores	Ingreso de gas para sistema vaporizador	TEC 24	[kg/h]	Digital	1 min
Potencia activa bruta	Bornes del Generador	PEM 735	[kW]	Digital	1 seg
Potencia reactiva bruta	Bornes del Generador	PEM 735	[kVAr]	Digital	1 seg
Tensión	Bornes del Generador	PEM 735	[V]	Digital	1 seg
Frecuencia	Bornes del Generador	PEM 735	[Hz]	Digital	1 seg
Potencia activa neta	Patio AT lado 66 kV	ION 8650	[kW]	Digital	1 min
Velocidad del rotor	Pick Up cigüeña	Sistema SCADA	[1/min]	Digital	1 min
Temperatura del refrigerante	Salida del block	Sistema SCADA	[°C]	Digital	1 min
Temperatura de gases de escape	Salida de gases	Sistema SCADA	[°C]	Digital	1 min
Temperatura del combustible	Ingreso de admisión	Sistema SCADA	[°C]	Digital	1 min
Temperatura del aceite	Circuito de retorno	Sistema SCADA	[°C]	Digital	1 min
Presión de aceite	Posterior a filtro	Sistema SCADA	[°C]	Digital	1 min
Temperatura ambiente	Subestación Aguas Claras	Estacion de monitoreo ambiental	[°C]	Digital	1 min
Humedad relativa	Subestación Aguas Claras	Estacion de monitoreo ambiental	[%]	Digital	1 min
Presión atmosférica	Subestación Aguas Claras	Estacion de monitoreo ambiental	[mBar]	Digital	1 min

6.7. Finalización de la prueba

Una vez dado cumplimiento de lo establecido en el punto 6.4, el experto técnico dió por finalizada la prueba, dejando el debido registro en el acta de prueba, la cual fué firmada por todos los presentes.

7. CONDICIONES PARTICULARES

7.1. Suspensión y reanudación de la prueba

Para el caso de la Nave #2, el día 03/12 se suspendió la prueba debido a un fallo en un transformador elevador. Se reemplazó el transformador y, de común acuerdo entre el Coordinador y el Coordinado, el día 05/12 se repitió la prueba.

Durante la repetición de la prueba de la Nave #2 se detuvo el Generador #10 durante 20 minutos para reemplazar 4 bujías y luego se volvió a sincronizar. Debido a esto se decidió extender la prueba por 30 minutos adicionales para lograr la cantidad de segmentos de medición válidos.

8. RESULTADOS DE LA PRUEBA

8.1. Metodología de obtención y validación de datos de potencia

Para la obtención de los datos de potencia tanto neta como bruta se realizó la medición en 10 segmentos de 30 mediciones cada uno con una tasa de muestreo de 1 minuto.

En la figura a continuación, se muestra la matriz de toma de datos en donde:

P_{msn} → corresponde a la potencia medida "m" del segmento "n"

P_{nn} → corresponde a la potencia medida del segmento "n" en el minuto "n"

P_{ms1}	=	PROMEDIO	(P_{11}	P_{12}	P_{13}	P_{14}	P_{15}	P_{16}	P_{17}	P_{18}	P_{19}	P_{20}	P_{21}	P_{22}	P_{23}	P_{24}	P_{25}	P_{26}	P_{27}	P_{28}	P_{29}	P_{30}	P_{31}	P_{32}	P_{33}	P_{34}	P_{35}	P_{36}	P_{37}	P_{38}	P_{39}	P_{40}	P_{41}	P_{42}	P_{43}	P_{44}	P_{45}	P_{46}	P_{47}	P_{48}	P_{49}	P_{50}	P_{51}	P_{52}	P_{53}	P_{54}	P_{55}	P_{56}	P_{57}	P_{58}	P_{59}	P_{60}	P_{61}	P_{62}	P_{63}	P_{64}	P_{65}	P_{66}	P_{67}	P_{68}	P_{69}	P_{70}	P_{71}	P_{72}	P_{73}	P_{74}	P_{75}	P_{76}	P_{77}	P_{78}	P_{79}	P_{80}	P_{81}	P_{82}	P_{83}	P_{84}	P_{85}	P_{86}	P_{87}	P_{88}	P_{89}	P_{90}	P_{91}	P_{92}	P_{93}	P_{94}	P_{95}	P_{96}	P_{97}	P_{98}	P_{99}	P_{100}	P_{101}	P_{102}	P_{103}	P_{104}	P_{105}	P_{106}	P_{107}	P_{108}	P_{109}	P_{110}	P_{111}	P_{112}	P_{113}	P_{114}	P_{115}	P_{116}	P_{117}	P_{118}	P_{119}	P_{120}	P_{121}	P_{122}	P_{123}	P_{124}	P_{125}	P_{126}	P_{127}	P_{128}	P_{129}	P_{130})
P_{ms2}	=	PROMEDIO	(P_{21}	P_{22}	P_{23}	P_{24}	P_{25}	P_{26}	P_{27}	P_{28}	P_{29}	P_{30}	P_{31}	P_{32}	P_{33}	P_{34}	P_{35}	P_{36}	P_{37}	P_{38}	P_{39}	P_{40}	P_{41}	P_{42}	P_{43}	P_{44}	P_{45}	P_{46}	P_{47}	P_{48}	P_{49}	P_{50}	P_{51}	P_{52}	P_{53}	P_{54}	P_{55}	P_{56}	P_{57}	P_{58}	P_{59}	P_{60}	P_{61}	P_{62}	P_{63}	P_{64}	P_{65}	P_{66}	P_{67}	P_{68}	P_{69}	P_{70}	P_{71}	P_{72}	P_{73}	P_{74}	P_{75}	P_{76}	P_{77}	P_{78}	P_{79}	P_{80}	P_{81}	P_{82}	P_{83}	P_{84}	P_{85}	P_{86}	P_{87}	P_{88}	P_{89}	P_{90}	P_{91}	P_{92}	P_{93}	P_{94}	P_{95}	P_{96}	P_{97}	P_{98}	P_{99}	P_{100}	P_{101}	P_{102}	P_{103}	P_{104}	P_{105}	P_{106}	P_{107}	P_{108}	P_{109}	P_{110}	P_{111}	P_{112}	P_{113}	P_{114}	P_{115}	P_{116}	P_{117}	P_{118}	P_{119}	P_{120}	P_{121}	P_{122}	P_{123}	P_{124}	P_{125}	P_{126}	P_{127}	P_{128}	P_{129}	P_{130})										
P_{ms3}	=	PROMEDIO	(P_{31}	P_{32}	P_{33}	P_{34}	P_{35}	P_{36}	P_{37}	P_{38}	P_{39}	P_{40}	P_{41}	P_{42}	P_{43}	P_{44}	P_{45}	P_{46}	P_{47}	P_{48}	P_{49}	P_{50}	P_{51}	P_{52}	P_{53}	P_{54}	P_{55}	P_{56}	P_{57}	P_{58}	P_{59}	P_{60}	P_{61}	P_{62}	P_{63}	P_{64}	P_{65}	P_{66}	P_{67}	P_{68}	P_{69}	P_{70}	P_{71}	P_{72}	P_{73}	P_{74}	P_{75}	P_{76}	P_{77}	P_{78}	P_{79}	P_{80}	P_{81}	P_{82}	P_{83}	P_{84}	P_{85}	P_{86}	P_{87}	P_{88}	P_{89}	P_{90}	P_{91}	P_{92}	P_{93}	P_{94}	P_{95}	P_{96}	P_{97}	P_{98}	P_{99}	P_{100}	P_{101}	P_{102}	P_{103}	P_{104}	P_{105}	P_{106}	P_{107}	P_{108}	P_{109}	P_{110}	P_{111}	P_{112}	P_{113}	P_{114}	P_{115}	P_{116}	P_{117}	P_{118}	P_{119}	P_{120}	P_{121}	P_{122}	P_{123}	P_{124}	P_{125}	P_{126}	P_{127}	P_{128}	P_{129}	P_{130})																				
P_{ms4}	=	PROMEDIO	(P_{41}	P_{42}	P_{43}	P_{44}	P_{45}	P_{46}	P_{47}	P_{48}	P_{49}	P_{50}	P_{51}	P_{52}	P_{53}	P_{54}	P_{55}	P_{56}	P_{57}	P_{58}	P_{59}	P_{60}	P_{61}	P_{62}	P_{63}	P_{64}	P_{65}	P_{66}	P_{67}	P_{68}	P_{69}	P_{70}	P_{71}	P_{72}	P_{73}	P_{74}	P_{75}	P_{76}	P_{77}	P_{78}	P_{79}	P_{80}	P_{81}	P_{82}	P_{83}	P_{84}	P_{85}	P_{86}	P_{87}	P_{88}	P_{89}	P_{90}	P_{91}	P_{92}	P_{93}	P_{94}	P_{95}	P_{96}	P_{97}	P_{98}	P_{99}	P_{100}	P_{101}	P_{102}	P_{103}	P_{104}	P_{105}	P_{106}	P_{107}	P_{108}	P_{109}	P_{110}	P_{111}	P_{112}	P_{113}	P_{114}	P_{115}	P_{116}	P_{117}	P_{118}	P_{119}	P_{120}	P_{121}	P_{122}	P_{123}	P_{124}	P_{125}	P_{126}	P_{127}	P_{128}	P_{129}	P_{130})																														
P_{ms5}	=	PROMEDIO	(P_{51}	P_{52}	P_{53}	P_{54}	P_{55}	P_{56}	P_{57}	P_{58}	P_{59}	P_{60}	P_{61}	P_{62}	P_{63}	P_{64}	P_{65}	P_{66}	P_{67}	P_{68}	P_{69}	P_{70}	P_{71}	P_{72}	P_{73}	P_{74}	P_{75}	P_{76}	P_{77}	P_{78}	P_{79}	P_{80}	P_{81}	P_{82}	P_{83}	P_{84}	P_{85}	P_{86}	P_{87}	P_{88}	P_{89}	P_{90}	P_{91}	P_{92}	P_{93}	P_{94}	P_{95}	P_{96}	P_{97}	P_{98}	P_{99}	P_{100}	P_{101}	P_{102}	P_{103}	P_{104}	P_{105}	P_{106}	P_{107}	P_{108}	P_{109}	P_{110}	P_{111}	P_{112}	P_{113}	P_{114}	P_{115}	P_{116}	P_{117}	P_{118}	P_{119}	P_{120}	P_{121}	P_{122}	P_{123}	P_{124}	P_{125}	P_{126}	P_{127}	P_{128}	P_{129}	P_{130})																																								
P_{ms6}	=	PROMEDIO	(P_{61}	P_{62}	P_{63}	P_{64}	P_{65}	P_{66}	P_{67}	P_{68}	P_{69}	P_{70}	P_{71}	P_{72}	P_{73}	P_{74}	P_{75}	P_{76}	P_{77}	P_{78}	P_{79}	P_{80}	P_{81}	P_{82}	P_{83}	P_{84}	P_{85}	P_{86}	P_{87}	P_{88}	P_{89}	P_{90}	P_{91}	P_{92}	P_{93}	P_{94}	P_{95}	P_{96}	P_{97}	P_{98}	P_{99}	P_{100}	P_{101}	P_{102}	P_{103}	P_{104}	P_{105}	P_{106}	P_{107}	P_{108}	P_{109}	P_{110}	P_{111}	P_{112}	P_{113}	P_{114}	P_{115}	P_{116}	P_{117}	P_{118}	P_{119}	P_{120}	P_{121}	P_{122}	P_{123}	P_{124}	P_{125}	P_{126}	P_{127}	P_{128}	P_{129}	P_{130})																																																		
P_{ms7}	=	PROMEDIO	(P_{71}	P_{72}	P_{73}	P_{74}	P_{75}	P_{76}	P_{77}	P_{78}	P_{79}	P_{80}	P_{81}	P_{82}	P_{83}	P_{84}	P_{85}	P_{86}	P_{87}	P_{88}	P_{89}	P_{90}	P_{91}	P_{92}	P_{93}	P_{94}	P_{95}	P_{96}	P_{97}	P_{98}	P_{99}	P_{100}	P_{101}	P_{102}	P_{103}	P_{104}	P_{105}	P_{106}	P_{107}	P_{108}	P_{109}	P_{110}	P_{111}	P_{112}	P_{113}	P_{114}	P_{115}	P_{116}	P_{117}	P_{118}	P_{119}	P_{120}	P_{121}	P_{122}	P_{123}	P_{124}	P_{125}	P_{126}	P_{127}	P_{128}	P_{129}	P_{130})																																																												
P_{ms8}	=	PROMEDIO	(P_{81}	P_{82}	P_{83}	P_{84}	P_{85}	P_{86}	P_{87}	P_{88}	P_{89}	P_{90}	P_{91}	P_{92}	P_{93}	P_{94}	P_{95}	P_{96}	P_{97}	P_{98}	P_{99}	P_{100}	P_{101}	P_{102}	P_{103}	P_{104}	P_{105}	P_{106}	P_{107}	P_{108}	P_{109}	P_{110}	P_{111}	P_{112}	P_{113}	P_{114}	P_{115}	P_{116}	P_{117}	P_{118}	P_{119}	P_{120}	P_{121}	P_{122}	P_{123}	P_{124}	P_{125}	P_{126}	P_{127}	P_{128}	P_{129}	P_{130})																																																																						
P_{ms9}	=	PROMEDIO	(P_{91}	P_{92}	P_{93}	P_{94}	P_{95}	P_{96}	P_{97}	P_{98}	P_{99}	P_{100}	P_{101}	P_{102}	P_{103}	P_{104}	P_{105}	P_{106}	P_{107}	P_{108}	P_{109}	P_{110}	P_{111}	P_{112}	P_{113}	P_{114}	P_{115}	P_{116}	P_{117}	P_{118}	P_{119}	P_{120}	P_{121}	P_{122}	P_{123}	P_{124}	P_{125}	P_{126}	P_{127}	P_{128}	P_{129}	P_{130})																																																																																
P_{ms10}	=	PROMEDIO	(P_{101}	P_{102}	P_{103}	P_{104}	P_{105}	P_{106}	P_{107}	P_{108}	P_{109}	P_{110}	P_{111}	P_{112}	P_{113}	P_{114}	P_{115}	P_{116}	P_{117}	P_{118}	P_{119}	P_{120}	P_{121}	P_{122}	P_{123}	P_{124}	P_{125}	P_{126}	P_{127}	P_{128}	P_{129}	P_{130})																																																																																										

Figura 8.1 – Matriz de datos medidos por segmento

8.2. Determinación de la potencia bruta en bornes del generador [P_b]

Para la determinación de la potencia bruta en los bornes de cada generador se utilizó la formula a continuación tomando como base lo expuesto en el punto 8.1.

$$P_b = \frac{P_{ms1} + P_{ms2} + \dots + P_{ms10}}{10} [kW]$$

Donde:

P_b → Potencia bruta en bornes de la unidad

P_{msn} → Potencia bruta medida en bornes de la unidad del segmento "n"

NOTA: Se tomaron mediciones en cuatro puntos; el promedio de estas mediciones se adoptó como la potencia bruta de cada unidad.

$$P_{bpu} = \frac{P_{bpu1} + P_{bpu2} + P_{bpu3} + P_{bpu4}}{4} [kW]$$

Donde:

P_{bpu} → Potencia bruta por unidad [kW]

8.3. Determinación de la potencia neta de la nave

Para determinar la potencia neta de la nave se realizó una medición de la potencia en el lado de alta del transformador de 66 kV, y luego se le descontó la potencia medida en el tablero de servicios auxiliares:

$$P_{nt} = \left[\frac{P_{ms1} + P_{ms2} + \dots + P_{ms10}}{10} \right] - P_{SSAA} [kW]$$

Donde:

P_{nt} → Potencia neta total

P_{msn} → Potencia neta medida en la salida del trafo de 66kV del segmento "n"(*)

P_{SSAA} → Potencia consumida por los servicios auxiliares

(*) Esta medición se tomará con el criterio de la matriz detallada en el punto 8.1.

La potencia neta por unidad será igual a la potencia neta total dividida entre la cantidad de generadores de la nave.

8.4. Potencias corregidas

Para este caso los sistemas de control tienen incorporados los ábacos de corrección y limitación de potencia en función de la temperatura de aire de admisión: Durante toda la prueba no actuó ningún limitador por lo que se considera como factor de corrección igual a 1.

8.5. Cuadro resumen de los resultados

POTENCIA MAXIMA BRUTA			
NAVE #1	MEDIDA	[kW]	1.716,76
	CORREGIDA	[kW]	1.667,15

POTENCIA MAXIMA NETA		
CALCULADA	[kW]	1.674,83
CORREGIDA	[kW]	1.625,21

POTENCIA MAXIMA BRUTA			
NAVE #2	MEDIDA	[kW]	1.717,81
	CORREGIDA	[kW]	1.668,17

POTENCIA MAXIMA NETA		
CALCULADA	[kW]	1.679,12
CORREGIDA	[kW]	1.629,48

POTENCIA MAXIMA BRUTA			
NAVE #3	MEDIDA	[kW]	1.707,28
	CORREGIDA	[kW]	1.641,54

POTENCIA MAXIMA NETA		
CALCULADA	[kW]	1.677,55
CORREGIDA	[kW]	1.611,82

POTENCIA MAXIMA BRUTA			
NAVE #4	MEDIDA	[kW]	1.709,55
	CORREGIDA	[kW]	1.643,74

POTENCIA MAXIMA NETA		
CALCULADA	[kW]	1.676,19
CORREGIDA	[kW]	1.610,37

9. NORMAS APLICABLES

- Anexo Técnico: “Res. Ex. N°375 20160422 AT Pruebas de Potencia Máxima en Unidades Generadoras”
- ASME - PTC 17 – “Reciprocating Internal Combustion Engines”
- ISO 1550: 2016 – “Internal combustion engines - Determination and method for the measurement of engine power - General requirements”
- ASME PTC 19.1 “Test Uncertainty”

10. ANEXOS

- **ANEXO I:** Datos de la medición de Potencia Máxima
- **ANEXO II:** Diagrama unifilar de la planta
- **ANEXO III:** Especificaciones de los equipos de medición
- **ANEXO IV:** Certificados de calibración de los equipos de medición
- **ANEXO V:** Datos característicos del grupo motor-generator
- **ANEXO VI:** Certificado de análisis del combustible

ANEXO I

Datos de la medición de Potencia Máxima

POTENCIA MÁXIMA NAVE #1

dic-19

SEGMENTO >>>	1	2	3	4	5	6	7	8	9	10
HORA >>>	20:30	21:00	21:30	22:00	22:30	23:00	23:30	00:00	00:30	01:00

VARIABLES MEDIDAS	Unidad	Límite	1	2	3	4	5	6	7	8	9	10
Potencia Bruta	[kW]		1.709,13	1.724,50	1.729,63	1.716,63	1.709,00	1.713,88	1.717,75	1.723,13	1.718,75	1.705,25
Factor de Potencia			0,98	0,98	0,98	0,98	0,98	0,98	0,98	0,98	0,98	0,98
Frecuencia	[Hz]		49,93	49,95	49,97	49,98	49,99	50,02	49,99	49,98	49,98	49,99
Temperatura de Refrigerante	[°C]		88,99	89,66	89,57	89,60	89,54	89,56	89,62	89,59	89,57	89,60
Temperatura	[°C]		21,97	21,15	20,36	19,76	19,12	18,76	18,46	17,89	17,34	16,69
Humedad Relativa	[%]		41,97	45,04	47,90	50,35	52,78	53,84	54,63	56,56	59,34	61,82

VERIFICACIÓN DE ESTABILIDAD

Potencia Bruta	[%]	±3	0,862	1,047	0,988	0,588	0,912	1,043	0,761	0,788	0,944	0,662
Frecuencia	[%]	±1	0,089	0,064	0,052	0,015	0,039	0,044	0,122	0,073	0,032	0,076
Temperatura de Refrigerante	[°C]	±2	1,831	0,099	0,134	0,141	0,150	0,154	0,155	0,146	0,154	0,163
Cumple			SI	SI	SI	SI	SI	SI	SI	SI	SI	SI

POTENCIA BRUTA MEDIDA	[kW]		1.709,13	1.724,50	1.729,63	1.716,63	1.709,00	1.713,88	1.717,75	1.723,13	1.718,75	1.705,25
POTENCIA TRAF0 66 KV LADO AT	[kW]		1.696,33	1.696,27	1.695,96	1.695,61	1.695,87	1.695,78	1.695,68	1.695,53	1.695,31	1.688,68
SERVICIOS AUXILIARES	[kW]		20,24	20,17	20,20	20,47	20,01	20,48	20,20	20,42	20,42	20,12
POTENCIA NETA CALCULADA	[kW]		1.676,09	1.675,10	1.675,76	1.675,15	1.675,85	1.675,31	1.675,48	1.675,11	1.674,88	1.668,56

CORRECCIONES*

Por temperatura de admisión			1,00	1,00	1,00	1,00	1,00	1,00	1,00	1,00	1,00	1,00
Por humedad relativa			1,00000	1,00000	1,00000	1,00000	1,00000	1,00000	1,00000	1,00000	1,00000	1,00000
Por factor de potencia			0,9711	0,9711	0,9711	0,9711	0,9711	0,9711	0,9711	0,9711	0,9711	0,9711

POTENCIA BRUTA CORREGIDA	[kW]		1.659,73	1.674,66	1.679,64	1.667,01	1.659,61	1.664,34	1.668,11	1.673,33	1.669,08	1.655,97
POTENCIA NETA CORREGIDA	[kW]		1.627,65	1.627,66	1.627,33	1.626,73	1.627,42	1.626,89	1.627,05	1.626,70	1.626,48	1.620,34

POTENCIA MAXIMA BRUTA	
MEDIDA	[kW]
CORREGIDA	[kW]

POTENCIA MAXIMA NETA	
CALCULADA	[kW]
CORREGIDA	[kW]

(*) Solo se realiza corrección por factor de potencia distinto a 0,95, el resto de las correcciones no se realizan ya que no se superaron los límites de corrección.

POTENCIA MÁXIMA NAVE #2

dic-19

SEGMENTO >>>	1	2	3	4	5	6	7	8	9	10
HORA >>>	21:50	22:20	22:50	23:20	23:50	00:20	00:50	01:20	01:50	02:20

VARIABLES MEDIDAS	Unidad	Límite
Potencia Bruta	[kW]	
Factor de Potencia	[kW]	
Frecuencia	[Hz]	
Temperatura de Refrigerante	[°C]	
Temperatura	[°C]	
Humedad Relativa	[%]	

VERIFICACIÓN DE ESTABILIDAD	Unidad	Límite
Potencia Bruta	[%]	±3
Frecuencia	[%]	±1
Temperatura de Refrigerante	[°C]	±2
Cumple	SI	SI

POTENCIA BRUTA MEDIDA	1.711,98	1.722,10	1.719,23	1.714,10	1.715,10	1.713,60	1.724,85	1.717,60	1.720,35	1.719,23
POTENCIA TRAF0 66 KV LADO AT	1.700,11	1.699,57	1.699,33	1.699,25	1.699,31	1.699,20	1.699,11	1.699,00	1.699,12	1.699,10
SERVICIOS AUXILIARES	20,16	20,37	20,27	20,39	19,99	20,53	19,89	20,35	19,81	20,12
POTENCIA NETA CALCULADA	1.679,96	1.679,20	1.679,05	1.678,87	1.679,32	1.678,67	1.679,22	1.678,65	1.679,31	1.678,98

CORRECCIONES*	Unidad	Límite
Por temperatura de admisión	1,00	1,00
Por humedad relativa	1,00000	1,00000
Por factor de potencia	0,9711	0,9711

POTENCIA BRUTA CORREGIDA	1.662,50	1.672,33	1.669,54	1.664,56	1.665,53	1.664,08	1.675,00	1.667,96	1.670,63	1.669,54
POTENCIA NETA CORREGIDA	1.631,41	1.630,67	1.630,53	1.630,35	1.630,79	1.630,16	1.630,69	1.630,14	1.630,77	1.630,46

POTENCIA MAXIMA BRUTA	
MEDIDA	1.717,81
CORREGIDA	1.668,17

POTENCIA MAXIMA NETA	
CALCULADA	1.679,12
CORREGIDA	1.629,48

(*) Solo se realiza corrección por factor de potencia distinto a 0,95, el resto de las correcciones no se realizan ya que no se superaron los límites de corrección.

POTENCIA MÁXIMA NAVE #3

dic-19

SEGMENTO >>>	1	2	3	4	5	6	7	8	9	10
HORA >>>	02:15	02:45	03:15	03:45	04:15	04:45	05:15	05:45	06:15	06:45
Unidad	Límite									

VARIABLES MEDIDAS

	1	2	3	4	5	6	7	8	9	10
Potencia Bruta	1.708,13	1.706,63	1.708,88	1.705,50	1.710,25	1.709,75	1.708,38	1.708,88	1.704,38	1.702,00
Factor de Potencia	0,99	0,99	0,99	0,99	0,99	0,99	0,99	0,99	0,99	0,99
Frecuencia	49,91	49,96	49,97	49,98	49,99	49,99	49,99	50,00	49,99	50,02
Temperatura de Refrigerante	88,62	89,40	89,43	89,43	89,49	89,51	89,53	89,49	89,48	89,53
Temperatura	14,97	14,36	13,68	12,95	11,70	10,96	10,27	10,22	10,51	10,80
Humedad Relativa	69,84	71,47	74,23	75,86	65,15	64,96	67,82	70,03	71,39	72,96

VERIFICACIÓN DE ESTABILIDAD

Potencia Bruta	±3	0,363	0,507	0,114	0,311	0,269	0,352	0,547	0,382	0,300	6,499
Frecuencia	±1	0,075	0,054	0,053	0,047	0,057	0,027	0,099	0,123	0,068	0,149
Temperatura de Refrigerante	±2	1,662	0,137	0,144	0,161	0,165	0,150	0,165	0,177	0,170	0,171
Cumple		SI	SI	SI	SI	SI	SI	SI	SI	SI	SI

POTENCIA BRUTA MEDIDA

POTENCIA TRAF0 66 KV LADO AT	1.708,13	1.706,63	1.708,88	1.705,50	1.710,25	1.709,75	1.708,38	1.708,88	1.704,38	1.702,00
SERVICIOS AUXILIARES	1.697,84	1.697,52	1.697,73	1.697,76	1.697,73	1.697,69	1.697,77	1.697,71	1.697,71	1.698,03
POTENCIA NETA CALCULADA	20,39	20,12	20,18	20,08	20,08	20,08	20,29	20,30	20,16	20,37
	1.677,45	1.677,40	1.677,56	1.677,68	1.677,65	1.677,61	1.677,48	1.677,42	1.677,56	1.677,66

CORRECCIONES*

Por temperatura de admisión	1,00	1,00	1,00	1,00	1,00	1,00	1,00	1,00	1,00	1,00
Por humedad relativa	1,00000	1,00000	1,00000	1,00000	1,00000	1,00000	1,00000	1,00000	1,00000	1,00000
Por factor de potencia	0,9615	0,9615	0,9615	0,9615	0,9615	0,9615	0,9615	0,9615	0,9615	0,9615

POTENCIA BRUTA CORREGIDA

POTENCIA BRUTA CORREGIDA	1.642,36	1.640,92	1.643,08	1.639,84	1.644,41	1.643,92	1.642,60	1.643,08	1.638,76	1.636,47
POTENCIA NETA CORREGIDA	1.612,87	1.612,82	1.612,97	1.613,09	1.613,06	1.613,02	1.612,90	1.612,83	1.612,97	1.613,07

POTENCIA MAXIMA BRUTA

MEDIDA	[kW]	1.707,28
CORREGIDA	[kW]	1.641,54

POTENCIA MAXIMA NETA

CALCULADA	[kW]	1.677,55
CORREGIDA	[kW]	1.611,82

(*) Solo se realiza corrección por factor de potencia distinto a 0,95, el resto de las correcciones no se realizan ya que no se superaron los límites de corrección.

POTENCIA MÁXIMA NAVE #4

dic-19

SEGMENTO >>>	1	2	3	4	5	6	7	8	9	10
HORA >>>	20:10	20:40	21:10	21:40	22:10	22:40	23:10	23:40	00:10	00:40

VARIABLES MEDIDAS	Unidad		Límite									
Potencia Bruta	[kW]		1.706,75	1.706,88	1.708,13	1.709,38	1.711,25	1.709,88	1.711,00	1.712,13	1.709,63	1.710,53
Factor de Potencia			0,99	0,99	0,99	0,99	0,99	0,99	0,99	0,99	0,99	0,99
Frecuencia	[Hz]		49,98	49,98	49,99	49,97	49,99	49,99	50,00	50,01	50,00	49,99
Temperatura de Refrigerante	[°C]		90,04	90,24	90,10	90,03	89,81	89,75	89,82	89,90	89,96	90,00
Temperatura	[°C]		22,26	20,46	18,77	17,99	18,14	17,10	16,37	15,47	16,30	17,51
Humedad Relativa	[%]		29,57	33,65	37,80	40,98	38,85	42,53	45,44	50,19	46,18	45,98

VERIFICACIÓN DE ESTABILIDAD												
Potencia Bruta	[%]	±3	0,249	0,176	0,217	0,279	0,145	0,176	0,248	0,361	0,258	0,350
Frecuencia	[%]	±1	0,052	0,085	0,053	0,069	0,044	0,039	0,069	0,046	0,044	0,073
Temperatura de Refrigerante	[°C]	±2	0,722	0,185	0,047	0,170	0,141	0,211	0,246	0,201	0,175	0,144
Cumple			SI	SI	SI	SI	SI	SI	SI	SI	SI	SI

POTENCIA BRUTA MEDIDA	[kW]	1.706,75	1.706,88	1.708,13	1.709,38	1.711,25	1.709,88	1.711,00	1.712,13	1.709,63	1.710,53
POTENCIA TRAF0 66 KV LADO AT	[kW]	1.676,66	1.698,41	1.698,62	1.698,68	1.698,66	1.698,54	1.698,06	1.698,06	1.697,96	1.698,15
SERVICIOS AUXILIARES	[kW]	19,82	19,88	20,18	20,03	20,21	19,61	20,13	19,77	20,16	20,12
POTENCIA NETA CALCULADA	[kW]	1.656,84	1.678,54	1.678,43	1.678,65	1.678,45	1.678,93	1.677,92	1.678,29	1.677,79	1.678,03

CORRECCIONES*												
Por temperatura de admisión		1,00	1,00	1,00	1,00	1,00	1,00	1,00	1,00	1,00	1,00	1,00
Por humedad relativa		1,00000	1,00000	1,00000	1,00000	1,00000	1,00000	1,00000	1,00000	1,00000	1,00000	1,00000
Por factor de potencia		0,9615	0,9615	0,9615	0,9615	0,9615	0,9615	0,9615	0,9615	0,9615	0,9615	0,9615

POTENCIA BRUTA CORREGIDA	[kW]	1.641,04	1.641,16	1.642,36	1.643,56	1.645,37	1.644,04	1.645,13	1.646,21	1.643,80	1.644,67
POTENCIA NETA CORREGIDA	[kW]	1.593,06	1.613,91	1.613,81	1.614,02	1.613,83	1.614,29	1.613,32	1.613,67	1.613,20	1.613,42

POTENCIA MAXIMA BRUTA		
MEDIDA	[kW]	1.709,55
CORREGIDA	[kW]	1.643,74

POTENCIA MAXIMA NETA		
CALCULADA	[kW]	1.676,19
CORREGIDA	[kW]	1.610,37

(*) Solo se realiza corrección por factor de potencia distinto a 0,95, el resto de las correcciones no se realizan ya que no se superaron los límites de corrección.

DATOS DE POTENCIA PROMEDIO POR NAVE

NAVE #1	SEGMENTO	1	2	3	4	5	6	7	8	9	10
	P	1.709,13	1.724,50	1.729,63	1.716,63	1.709,00	1.713,88	1.717,75	1.723,13	1.718,75	1.705,25
SD	14,67	18,03	17,15	10,08	15,56	17,85	13,08	13,61	16,26	11,31	
SD %	0,86	1,05	0,99	0,59	0,91	1,04	0,76	0,79	0,94	0,66	
PF	0,98	0,98	0,98	0,98	0,98	0,98	0,98	0,98	0,98	0,98	
SD	0,00	-	0,00	0,00	0,00	0,00	0,00	0,00	0,00	0,00	
SD %	0,09	-	0,04	0,09	0,05	0,04	0,05	0,05	0,02	0,05	
F	49,93	49,95	49,97	49,98	49,99	50,02	49,99	49,98	49,98	49,99	
SD	0,04	0,03	0,03	0,01	0,02	0,02	0,06	0,04	0,02	0,04	
SD%	0,09	0,06	0,05	0,02	0,04	0,04	0,12	0,07	0,03	0,08	

NAVE #2	SEGMENTO	1	2	3	4	5	6	7	8	9	10
	P	1.711,98	1.722,10	1.719,23	1.714,10	1.715,10	1.713,60	1.724,85	1.717,60	1.720,35	1.719,23
SD	11,84	1,77	3,36	14,50	1,77	6,36	4,60	10,61	1,06	6,19	
SD %	0,70	0,10	0,20	0,86	0,10	0,38	0,27	0,63	0,06	0,37	
PF	0,98	0,98	0,98	0,98	0,98	0,98	0,98	0,98	0,98	0,98	
SD	0,00	-	-	0,00	0,00	0,00	0,00	0,00	-	0,00	
SD %	0,11	-	-	0,11	0,05	0,05	0,05	0,05	-	0,05	
F	49,98	49,96	49,98	49,99	49,98	50,01	50,02	49,98	49,97	49,98	
SD	0,04	0,02	0,04	0,03	0,01	0,05	0,04	0,02	0,01	0,00	
SD%	0,09	0,04	0,07	0,05	0,03	0,10	0,07	0,04	0,02	0,00	

NAVE #3	SEGMENTO	1	2	3	4	5	6	7	8	9	10
	P	1.708,13	1.706,63	1.708,88	1.705,50	1.710,25	1.709,75	1.708,38	1.708,88	1.704,38	1.702,00
SD	6,19	8,66	1,94	5,30	4,60	6,01	9,37	6,54	5,13	95,46	
SD %	0,36	0,51	0,11	0,31	0,27	0,35	0,55	0,38	0,30	6,50	
PF	0,99	0,99	0,99	0,99	0,99	0,99	0,99	0,99	0,99	0,99	
SD	0,00	-	-	0,00	0,00	0,00	0,00	0,00	0,00	0,00	
SD %	0,05	-	-	0,04	0,04	0,12	0,04	0,04	0,02	0,07	
F	49,91	49,96	49,97	49,98	49,99	49,99	49,99	50,00	49,99	50,02	
SD	0,04	0,03	0,03	0,02	0,03	0,01	0,05	0,06	0,03	0,07	
SD%	0,08	0,05	0,05	0,05	0,06	0,03	0,10	0,12	0,07	0,15	

NAVE #4	SEGMENTO	1	2	3	4	5	6	7	8	9	10
	P	1.706,75	1.706,88	1.708,13	1.709,38	1.711,25	1.709,88	1.711,00	1.712,13	1.709,63	1.710,53
SD	4,24	3,01	3,71	4,77	2,47	3,01	4,24	6,19	4,42	5,25	
SD %	0,25	0,18	0,22	0,28	0,14	0,18	0,25	0,36	0,26	0,35	
PF	0,99	0,99	0,99	0,99	0,99	0,99	0,99	0,99	0,99	0,99	
SD	0,00	0,00	0,00	0,00	0,00	-	0,00	0,00	-	0,00	
SD %	0,05	0,02	0,07	0,04	0,04	-	0,02	0,02	-	0,02	
F	49,98	49,98	49,99	49,97	49,97	49,99	50,00	50,01	50,00	49,99	
SD	0,03	0,04	0,03	0,03	0,02	0,02	0,03	0,02	0,02	0,04	
SD%	0,05	0,08	0,05	0,07	0,04	0,04	0,07	0,05	0,04	0,07	

	SEGMENTO	POTENCIA ACTIVA	SD		PF	SD		F	SD	
		[kW]	[kW]	[%]			[%]		[Hz]	[Hz]
GEN #1	1,00	1.713,50	13,44	0,78	0,97	0,0014	0,1455	49,98	0,05	0,09
	2,00	1.744,00	19,80	1,14	0,97	-	-	49,96	0,02	0,04
	3,00	1.744,00	36,77	2,11	0,97	-	-	49,97	0,01	0,03
	4,00	1.713,50	12,02	0,70	0,97	0,0014	0,1455	49,97	0,01	0,03
	5,00	1.693,00	24,04	1,42	0,97	0,0007	0,0728	49,99	0,01	0,01
	6,00	1.723,00	26,87	1,56	0,97	0,0007	0,0728	50,03	0,05	0,10
	7,00	1.724,00	25,46	1,48	0,97	0,0007	0,0727	50,02	0,04	0,09
	8,00	1.732,50	19,09	1,10	0,97	0,0007	0,0727	49,97	0,02	0,04
	9,00	1.725,00	29,70	1,72	0,97	-	-	49,96	0,00	0,00
10,00	1.706,00	22,63	1,33	0,97	0,0007	0,0727	49,96	0,00	0,00	

	SEGMENTO	POTENCIA ACTIVA	SD		PF	SD		F	SD	
		[kW]	[kW]	[%]			[%]		[Hz]	[Hz]
GEN #2	1,00	1.712,00	2,83	0,17	0,99	-	-	49,88	0,05	0,09
	2,00	1.740,50	20,51	1,18	0,99	-	-	49,95	0,04	0,08
	3,00	1.733,00	11,31	0,65	0,99	-	-	49,97	0,01	0,03
	4,00	1.722,50	7,78	0,45	0,99	-	-	49,96	0,01	0,01
	5,00	1.714,50	9,19	0,54	0,99	0,0007	0,0713	49,99	0,05	0,09
	6,00	1.716,00	12,73	0,74	0,99	-	-	50,02	-	-
	7,00	1.728,50	12,02	0,70	0,99	0,0007	0,0713	49,94	0,11	0,23
	8,00	1.741,50	17,68	1,02	0,99	-	-	49,91	0,06	0,11
	9,00	1.730,00	24,04	1,39	0,99	0,0007	0,0712	49,94	0,00	0,00
10,00	1.712,50	14,85	0,87	0,99	0,0007	0,0712	49,99	0,06	0,13	

	SEGMENTO	POTENCIA ACTIVA	SD		PF	SD		F	SD	
		[kW]	[kW]	[%]			[%]		[Hz]	[Hz]
GEN #5	1,00	1.694,50	37,48	2,21	0,97	0,0014	0,1455	49,88	0,01	0,01
	2,00	1.693,50	26,16	1,54	0,97	-	-	49,90	0,02	0,04
	3,00	1.715,50	12,02	0,70	0,97	-	-	49,95	0,04	0,09
	4,00	1.708,50	19,09	1,12	0,97	0,0014	0,1455	49,98	0,00	0,00
	5,00	1.710,50	20,51	1,20	0,97	0,0007	0,0728	49,98	0,00	0,00
	6,00	1.697,00	24,04	1,42	0,97	0,0007	0,0728	49,98	0,01	0,03
	7,00	1.697,50	9,19	0,54	0,97	0,0007	0,0727	49,98	0,03	0,05
	8,00	1.699,00	11,31	0,67	0,97	0,0007	0,0727	50,04	0,05	0,11
	9,00	1.700,50	10,61	0,62	0,97	-	-	50,04	0,06	0,12
10,00	1.688,00	2,83	0,17	0,97	0,0007	0,0727	50,05	0,07	0,13	

	SEGMENTO	POTENCIA ACTIVA	SD		PF	SD		F	SD	
		[kW]	[kW]	[%]			[%]		[Hz]	[Hz]
GEN #7	1,00	1.716,50	4,95	0,29	0,99	0,0007	0,0714	49,97	0,08	0,16
	2,00	1.720,00	5,66	0,33	0,99	-	-	49,99	0,04	0,09
	3,00	1.726,00	8,49	0,49	0,99	0,0014	0,1428	49,98	0,03	0,06
	4,00	1.722,00	1,41	0,08	0,99	0,0007	0,0715	50,00	0,01	0,02
	5,00	1.718,00	8,49	0,49	0,99	-	-	50,01	0,02	0,05
	6,00	1.719,50	7,78	0,45	0,99	-	-	50,04	0,02	0,04
	7,00	1.721,00	5,66	0,33	0,99	-	-	50,01	0,06	0,12
	8,00	1.719,50	6,36	0,37	0,99	0,0007	0,0714	49,98	0,01	0,03
	9,00	1.719,50	0,71	0,04	0,99	-	-	49,99	0,00	0,00
10,00	1.714,50	4,95	0,29	0,99	-	-	49,98	0,02	0,04	

	SEGMENTO	POTENCIA ACTIVA	SD		PF	SD		F	SD	
		[kW]	[kW]	[%]			[%]		[Hz]	[Hz]
GEN #9	1,00	1.712,80	15,56	0,92	0,97	0,0014	0,1455	49,98	0,05	0,09
	2,00	1.725,30	2,12	0,13	0,97	-	-	49,96	0,02	0,04
	3,00	1.720,80	1,41	0,08	0,97	-	-	49,97	0,01	0,03
	4,00	1.713,30	19,09	1,13	0,97	0,0014	0,1455	49,97	0,01	0,03
	5,00	1.716,80	1,41	0,08	0,97	0,0007	0,0728	49,99	0,01	0,01
	6,00	1.715,80	7,07	0,42	0,97	0,0007	0,0728	50,03	0,05	0,10
	7,00	1.729,80	2,83	0,17	0,97	0,0007	0,0727	50,02	0,04	0,09
	8,00	1.719,80	12,73	0,75	0,97	0,0007	0,0727	49,97	0,02	0,04
	9,00	1.723,80	-	-	0,97	-	-	49,96	0,00	0,00
10,00	1.722,30	7,78	0,46	0,97	0,0007	0,0727	49,96	0,00	0,00	

	SEGMENTO	POTENCIA ACTIVA	SD		PF	SD		F	SD	
		[kW]	[kW]	[%]			[%]		[Hz]	[Hz]
GEN #11	1,00	1.709,50	0,71	0,04	1,00	-	-	49,99	0,03	0,06
	2,00	1.712,50	0,71	0,04	1,00	-	-	49,96	0,03	0,05
	3,00	1.714,50	9,19	0,54	1,00	-	-	50,00	0,10	0,20
	4,00	1.716,50	0,71	0,04	1,00	-	-	50,03	0,06	0,12
	5,00	1.710,00	2,83	0,17	1,00	-	-	49,96	0,04	0,08
	6,00	1.707,00	4,24	0,25	1,00	-	-	49,97	0,05	0,09
	7,00	1.710,00	9,90	0,58	1,00	-	-	50,00	0,01	0,02
	8,00	1.711,00	4,24	0,25	1,00	-	-	49,98	0,01	0,02
	9,00	1.710,00	4,24	0,25	1,00	-	-	50,00	0,04	0,07
10,00	1.710,00	1,41	0,08	1,00	-	-	50,03	0,00	0,01	

	SEGMENTO	POTENCIA ACTIVA	SD		PF	SD		F	SD	
		[kW]	[kW]	[%]			[%]		[Hz]	[Hz]
GEN #12	1,00	1.712,80	15,56	0,92	0,97	0,0014	0,1455	49,98	0,05	0,09
	2,00	1.725,30	2,12	0,13	0,97	-	-	49,96	0,02	0,04
	3,00	1.720,80	1,41	0,08	0,97	-	-	49,97	0,01	0,03
	4,00	1.713,30	19,09	1,13	0,97	0,0014	0,1455	49,97	0,01	0,03
	5,00	1.716,80	1,41	0,08	0,97	0,0007	0,0728	49,99	0,01	0,01
	6,00	1.715,80	7,07	0,42	0,97	0,0007	0,0728	50,03	0,05	0,10
	7,00	1.729,80	2,83	0,17	0,97	0,0007	0,0727	50,02	0,04	0,09
	8,00	1.719,80	12,73	0,75	0,97	0,0007	0,0727	49,97	0,02	0,04
	9,00	1.723,80	-	-	0,97	-	-	49,96	0,00	0,00
10,00	1.722,30	7,78	0,46	0,97	0,0007	0,0727	49,96	0,00	0,00	

	SEGMENTO	POTENCIA ACTIVA	SD		PF	SD		F	SD	
		[kW]	[kW]	[%]			[%]		[Hz]	[Hz]
GEN #14	1,00	1.712,80	15,56	0,92	0,97	0,0014	0,1455	49,98	0,05	0,09
	2,00	1.725,30	2,12	0,13	0,97	-	-	49,96	0,02	0,04
	3,00	1.720,80	1,41	0,08	0,97	-	-	49,97	0,01	0,03
	4,00	1.713,30	19,09	1,13	0,97	0,0014	0,1455	49,97	0,01	0,03
	5,00	1.716,80	1,41	0,08	0,97	0,0007	0,0728	49,99	0,01	0,01
	6,00	1.715,80	7,07	0,42	0,97	0,0007	0,0728	50,03	0,05	0,10
	7,00	1.729,80	2,83	0,17	0,97	0,0007	0,0727	50,02	0,04	0,09
	8,00	1.719,80	12,73	0,75	0,97	0,0007	0,0727	49,97	0,02	0,04
	9,00	1.723,80	-	-	0,97	-	-	49,96	0,00	0,00
10,00	1.722,30	7,78	0,46	0,97	0,0007	0,0727	49,96	0,00	0,00	

	SEGMENTO	POTENCIA ACTIVA	SD		PF	SD		F	SD	
		[kW]	[kW]	[%]			[%]		[Hz]	[Hz]
GEN #15	1,00	1.708,00	9,90	0,58	0,97	0,0014	0,1455	49,88	0,01	0,01
	2,00	1.711,50	9,19	0,54	0,97	-	-	49,90	0,02	0,04
	3,00	1.712,00	4,24	0,25	0,97	-	-	49,95	0,04	0,09
	4,00	1.711,50	4,95	0,29	0,97	0,0014	0,1455	49,98	0,00	0,00
	5,00	1.711,50	2,12	0,12	0,97	0,0007	0,0728	49,98	0,00	0,00
	6,00	1.715,50	4,95	0,29	0,97	0,0007	0,0728	49,98	0,01	0,03
	7,00	1.709,00	9,90	0,58	0,97	0,0007	0,0727	49,98	0,03	0,05
	8,00	1.712,00	7,07	0,41	0,97	0,0007	0,0727	50,04	0,05	0,11
	9,00	1.714,00	7,07	0,41	0,97	-	-	50,04	0,06	0,12
10,00	1.706,00	3,54	0,21	0,97	0,0007	0,0727	50,05	0,07	0,13	

	SEGMENTO	POTENCIA ACTIVA	SD		PF	SD		F	SD	
		[kW]	[kW]	[%]			[%]		[Hz]	[Hz]
GEN #17	1,00	1.714,50	2,12	0,12	0,99	-	-	49,88	0,05	0,09
	2,00	1.713,50	12,02	0,70	0,99	-	-	49,95	0,04	0,08
	3,00	1.720,00	1,41	0,08	0,99	-	-	49,97	0,01	0,03
	4,00	1.708,50	6,36	0,37	0,99	-	-	49,96	0,01	0,01
	5,00	1.722,00	4,24	0,25	0,99	0,0007	0,0713	49,99	0,05	0,09
	6,00	1.716,00	4,24	0,25	0,99	-	-	50,02	-	-
	7,00	1.714,50	12,02	0,70	0,99	0,0007	0,0713	49,94	0,11	0,23
	8,00	1.704,50	4,95	0,29	0,99	-	-	49,91	0,06	0,11
	9,00	1.704,50	4,95	0,29	0,99	0,0007	0,0712	49,94	0,00	0,00
10,00	1.701,00	362,75	24,87	0,99	0,0007	0,0712	49,99	0,06	0,13	

	SEGMENTO	POTENCIA ACTIVA	SD		PF	SD		F	SD	
		[kW]	[kW]	[%]			[%]		[Hz]	[Hz]
GEN #18	1,00	1.708,50	4,95	0,29	1,00	0,0007	0,0709	49,92	0,01	0,01
	2,00	1.705,50	3,54	0,21	1,00	-	-	49,96	0,04	0,08
	3,00	1.708,50	0,71	0,04	1,00	-	-	49,96	0,00	0,00
	4,00	1.709,00	2,83	0,17	1,00	-	-	49,99	0,04	0,07
	5,00	1.709,50	4,95	0,29	1,00	-	-	49,99	0,04	0,09
	6,00	1.706,00	4,24	0,25	0,99	0,0042	0,4268	49,98	0,03	0,07
	7,00	1.717,00	12,73	0,74	0,99	-	-	50,04	0,06	0,11
	8,00	1.722,50	12,02	0,70	0,99	0,0007	0,0713	50,03	0,09	0,18
	9,00	1.702,00	7,07	0,42	0,99	-	-	49,97	0,00	0,00
10,00	1.704,00	12,02	0,71	0,99	0,0007	0,0712	50,01	0,05	0,11	

	SEGMENTO	POTENCIA ACTIVA	SD		PF	SD		F	SD	
		[kW]	[kW]	[%]			[%]		[Hz]	[Hz]
GEN #20	1,00	1.701,50	7,78	0,46	0,99	-	-	49,94	0,09	0,19
	2,00	1.696,00	9,90	0,58	0,99	-	-	50,02	0,00	0,01
	3,00	1.695,00	1,41	0,08	0,99	-	-	49,99	0,05	0,09
	4,00	1.693,00	7,07	0,42	0,99	-	-	49,99	0,05	0,10
	5,00	1.698,00	7,07	0,42	0,99	-	-	50,01	0,02	0,04
	6,00	1.701,50	10,61	0,62	0,99	-	-	50,00	0,00	0,01
	7,00	1.693,00	2,83	0,17	0,99	-	-	50,00	0,00	0,01
	8,00	1.696,50	2,12	0,13	0,99	-	-	50,04	0,04	0,09
	9,00	1.697,00	1,41	0,08	0,99	-	-	50,01	0,07	0,15
10,00	1.697,00	3,54	0,21	0,99	0,0007	0,0711	50,04	0,11	0,22	

	SEGMENTO	POTENCIA ACTIVA	SD		PF	SD		F	SD	
		[kW]	[kW]	[%]			[%]		[Hz]	[Hz]
GEN #21	1,00	1.707,00	2,83	0,17	0,99	0,0007	0,0714	49,97	0,08	0,16
	2,00	1.708,00	1,41	0,08	0,99	-	-	49,99	0,04	0,09
	3,00	1.714,50	9,19	0,54	0,99	0,0014	0,1428	49,98	0,03	0,06
	4,00	1.712,00	4,24	0,25	0,99	0,0007	0,0715	50,00	0,01	0,02
	5,00	1.705,50	3,54	0,21	0,99	-	-	50,01	0,02	0,05
	6,00	1.709,50	2,12	0,12	0,99	-	-	50,04	0,02	0,04
	7,00	1.706,00	1,41	0,08	0,99	-	-	50,01	0,06	0,12
	8,00	1.706,50	6,36	0,37	0,99	0,0007	0,0714	49,98	0,01	0,03
	9,00	1.701,50	0,71	0,04	0,99	-	-	49,99	0,00	0,00
10,00	1.673,50	50,20	3,00	0,99	-	-	49,98	0,02	0,04	

	SEGMENTO	POTENCIA ACTIVA	SD		PF	SD		F	SD	
		[kW]	[kW]	[%]			[%]		[Hz]	[Hz]
GEN #23	1,00	1.703,50	6,36	0,37	0,99	0,0007	0,0711	50,03	0,00	0,01
	2,00	1.712,50	6,36	0,37	0,99	0,0007	0,0711	50,00	0,06	0,12
	3,00	1.705,00	2,83	0,17	0,99	0,0007	0,0711	49,97	0,03	0,06
	4,00	1.711,50	10,61	0,62	0,99	-	-	49,97	0,02	0,03
	5,00	1.718,50	2,12	0,12	0,99	-	-	49,98	0,01	0,03
	6,00	1.713,00	4,24	0,25	0,99	-	-	49,97	0,02	0,05
	7,00	1.719,50	6,36	0,37	0,99	-	-	49,96	0,01	0,02
	8,00	1.716,50	12,02	0,70	0,99	-	-	50,00	0,05	0,10
	9,00	1.707,50	7,78	0,46	1,00	-	-	50,03	0,01	0,02
10,00	1.456,00	367,70	25,25	0,99	-	-	50,05	0,03	0,07	

	SEGMENTO	POTENCIA ACTIVA	SD		PF	SD		F	SD	
		[kW]	[kW]	[%]			[%]		[Hz]	[Hz]
GEN #24	1,00	1.709,50	2,12	0,12	0,99	-	-	49,98	0,02	0,04
	2,00	1.705,50	2,12	0,12	0,99	-	-	49,97	0,00	0,00
	3,00	1.706,00	1,41	0,08	0,99	0,0007	0,0711	49,96	0,03	0,06
	4,00	1.708,50	0,71	0,04	1,00	-	-	49,94	0,01	0,02
	5,00	1.713,50	0,71	0,04	0,99	0,0007	0,0711	49,97	0,02	0,04
	6,00	1.711,50	3,54	0,21	0,99	-	-	49,99	0,00	0,01
	7,00	1.710,50	4,95	0,29	0,99	-	-	50,01	0,02	0,04
	8,00	1.716,00	5,66	0,33	0,99	-	-	50,02	0,00	0,00
	9,00	1.719,50	7,78	0,45	0,99	-	-	49,98	0,05	0,10
10,00	1.714,00	-	-	0,99	-	-	50,00	0,07	0,14	

	SEGMENTO	POTENCIA ACTIVA	SD		PF	SD		F	SD	
		[kW]	[kW]	[%]			[%]		[Hz]	[Hz]
GEN #26	1,00	1.707,00	5,66	0,33	1,00	0,0007	0,0710	49,93	0,00	0,01
	2,00	1.701,50	2,12	0,12	1,00	-	-	49,97	0,06	0,12
	3,00	1.707,00	1,41	0,08	1,00	-	-	50,03	0,02	0,04
	4,00	1.705,50	3,54	0,21	1,00	0,0007	0,0710	49,97	0,10	0,20
	5,00	1.707,50	3,54	0,21	1,00	0,0007	0,0710	49,94	0,03	0,07
	6,00	1.705,50	2,12	0,12	1,00	-	-	49,96	0,03	0,06
	7,00	1.708,00	4,24	0,25	1,00	0,0007	0,0710	50,02	0,04	0,08
	8,00	1.709,50	0,71	0,04	1,00	-	-	50,02	0,03	0,05
	9,00	1.710,00	1,41	0,08	1,00	-	-	49,98	0,03	0,05
10,00	1.705,00	2,83	0,17	1,00	0,0007	0,0710	49,95	0,02	0,04	

RESUMEN DATOS DE HUMEDAD Y TEMPERATURA

		NAVE #1									
SEGMENTO		1	2	3	4	5	6	7	8	9	10
HR	[%]	41,97	45,04	47,90	50,35	52,78	53,84	54,63	56,56	59,34	61,82
SD	[%]	0,33	0,36	0,40	0,40	0,29	0,12	0,22	0,57	0,27	0,59
T	[°C]	21,97	21,15	20,36	19,76	19,12	18,76	18,46	17,89	17,34	16,69
SD	[°C]	0,21	0,20	0,24	0,19	0,14	0,09	0,15	0,29	0,09	0,27

		NAVE #2									
SEGMENTO		1	2	3	4	5	6	7	8	9	10
HR	[%]	38,88	41,74	44,51	46,96	50,11	53,59	56,19	58,80	60,87	63,14
SD	[%]	0,49	0,62	0,32	0,27	0,59	0,59	0,36	0,53	0,36	0,59
T	[°C]	20,50	19,81	19,51	19,24	18,87	18,18	17,72	16,98	16,45	15,88
SD	[°C]	0,46	0,39	0,13	0,06	0,19	0,18	0,19	0,21	0,15	0,20

		NAVE #3									
SEGMENTO		1	2	3	4	5	6	7	8	9	10
HR	[%]	69,84	71,47	74,23	75,86	65,15	64,96	67,82	70,03	71,39	72,96
SD	[%]	0,52	0,60	0,62	0,63	1,07	0,47	0,56	0,31	0,26	0,63
T	[°C]	14,97	14,36	13,68	12,95	11,70	10,96	10,27	10,22	10,51	10,80
SD	[°C]	0,26	0,23	0,17	0,35	0,28	0,22	0,16	0,11	0,14	0,07

		NAVE #4									
SEGMENTO		1	2	3	4	5	6	7	8	9	10
HR	[%]	29,57	33,65	37,80	40,98	38,85	42,53	45,44	50,19	46,18	45,98
SD	[%]	0,57	0,76	0,11	0,79	0,65	0,76	0,32	0,49	0,79	0,25
T	[°C]	22,26	20,46	18,77	17,99	18,14	17,10	16,37	15,47	16,30	17,51
SD	[°C]	0,76	0,61	0,23	0,45	0,37	0,38	0,17	0,22	0,69	0,27

TEMPERATURA REFRIGERANTE PROMEDIO NAVE #1

[hh:mm:ss]	[°C]	SEGMENTO	1	2	3	4	5	6	7	8	9	10
20:30:00	81,80											
20:30:05	82,70											
20:30:10	83,70											
20:30:15	83,70											
20:30:20	84,60											
20:30:25	85,60											
20:30:30	86,40											
20:30:35	87,30											
20:30:40	87,30											
20:30:45	88,00											
20:30:50	88,70											
20:30:55	89,20											
20:31:00	89,40											
20:31:05	89,20											
20:31:10	88,40											
20:31:15	88,40											
20:31:20	87,10											
20:31:25	85,50											
20:31:30	84,00											
20:31:35	82,60											
20:31:40	81,40											
20:31:45	80,60											
20:31:50	80,30											
20:31:55	80,30											
20:32:00	80,60											
20:32:05	81,40											
20:32:10	82,30											
20:32:15	83,30											
20:32:20	84,30											
20:32:25	85,40											
20:32:30	85,40											
20:32:35	86,40											
20:32:40	87,30											
20:32:45	88,30											
20:32:50	89,20											
20:32:55	89,90											
20:33:00	89,90											
20:33:05	90,60											
20:33:10	91,00											
20:33:15	90,80											
20:33:20	90,10											
20:33:25	89,00											
20:33:30	87,60											
20:33:35	87,60											
20:33:40	86,40											
20:33:45	85,30											
20:33:50	84,60											
20:33:55	84,40											
20:34:00	84,60											
20:34:05	85,30											
20:34:10	85,30											
20:34:15	86,30											
20:34:20	87,30											
20:34:25	88,50											
20:34:30	89,60											
20:34:35	90,50											
20:34:40	91,50											
20:34:45	91,90											
20:34:50	91,90											
20:34:55	91,80											
20:35:00	91,30											
20:35:05	90,40											
20:35:10	89,40											
20:35:15	88,30											
20:35:20	88,30											
20:35:25	87,40											
20:35:30	86,80											
20:35:35	86,40											
20:35:40	86,40											
20:35:45	86,40											
20:35:50	86,40											
20:35:55	86,80											
20:36:00	87,40											
20:36:05	88,20											
20:36:10	89,00											
20:36:15	89,70											
20:36:20	89,70											
20:36:25	90,70											
20:36:30	90,70											
20:36:35	91,00											
20:36:40	91,10											
20:36:45	91,00											
20:36:50	90,80											
20:36:55	90,50											
20:37:00	90,10											
20:37:05	90,10											
20:37:10	89,60											
20:37:15	89,10											
20:37:20	88,50											
20:37:25	88,00											
20:37:30	87,70											
20:37:35	87,50											
20:37:40	87,50											
20:37:45	87,60											

PROMEDIO
SD

88,991 89,662 89,570 89,603 89,539 89,557 89,616 89,589 89,574 89,602
1,83 0,10 0,13 0,14 0,15 0,15 0,16 0,15 0,15 0,16

20:37:50	87,80
20:37:55	88,20
20:38:00	88,70
20:38:05	89,30
20:38:10	89,30
20:38:15	89,80
20:38:20	90,40
20:38:25	90,80
20:38:30	91,20
20:38:35	91,40
20:38:40	91,50
20:38:45	91,50
20:38:50	91,40
20:38:55	91,10
20:39:00	90,80
20:39:05	90,30
20:39:10	89,80
20:39:15	89,40
20:39:20	89,40
20:39:25	89,10
20:39:30	88,90
20:39:35	88,80
20:39:40	88,90
20:39:45	89,10
20:39:50	89,30
20:39:55	89,30
20:40:00	89,40
20:40:05	89,70
20:40:10	90,10
20:40:15	90,20
20:40:20	90,40
20:40:25	90,50
20:40:30	90,50
20:40:35	90,60
20:40:40	90,50
20:40:45	90,40
20:40:50	90,30
20:40:55	90,10
20:41:00	90,10
20:41:05	90,10
20:41:10	89,80
20:41:15	89,70
20:41:20	89,60
20:41:25	89,60
20:41:30	89,60
20:41:35	89,60
20:41:40	89,60
20:41:45	89,60
20:41:50	89,70
20:41:55	89,70
20:42:00	89,70
20:42:05	89,80
20:42:10	89,80
20:42:15	89,80
20:42:20	89,90
20:42:25	89,90
20:42:30	89,90
20:42:35	89,80
20:42:40	89,80
20:42:45	89,80
20:42:50	89,80
20:42:55	89,70
20:43:00	89,70
20:43:05	89,70
20:43:10	89,70
20:43:15	89,70
20:43:20	89,70
20:43:25	89,70
20:43:30	89,70
20:43:35	89,70
20:43:40	89,70
20:43:45	89,70
20:43:50	89,70
20:43:55	89,70
20:44:00	89,70
20:44:05	89,60
20:44:10	89,60
20:44:15	89,60
20:44:20	89,60
20:44:25	89,60
20:44:30	89,40
20:44:35	89,40
20:44:40	89,40
20:44:45	89,40
20:44:50	89,40
20:44:55	89,40
20:45:00	89,40
20:45:05	89,40
20:45:10	89,40
20:45:15	89,40
20:45:20	89,40
20:45:25	89,40
20:45:30	89,40
20:45:35	89,40
20:45:40	89,40
20:45:45	89,40
20:45:50	89,40
20:45:55	89,40

20:46:00	89,40
20:46:05	89,40
20:46:10	89,40
20:46:15	89,40
20:46:20	89,40
20:46:25	89,40
20:46:30	89,40
20:46:35	89,30
20:46:40	89,30
20:46:45	89,30
20:46:50	89,30
20:46:55	89,30
20:47:00	89,20
20:47:05	89,20
20:47:10	89,20
20:47:15	89,20
20:47:20	89,20
20:47:25	89,20
20:47:30	89,20
20:47:35	89,20
20:47:40	89,20
20:47:45	89,30
20:47:50	89,30
20:47:55	89,30
20:48:00	89,30
20:48:05	89,30
20:48:10	89,40
20:48:15	89,40
20:48:20	89,40
20:48:25	89,40
20:48:30	89,40
20:48:35	89,40
20:48:40	89,40
20:48:45	89,40
20:48:50	89,40
20:48:55	89,40
20:49:00	89,40
20:49:05	89,40
20:49:10	89,40
20:49:15	89,30
20:49:20	89,30
20:49:25	89,30
20:49:30	89,20
20:49:35	89,20
20:49:40	89,20
20:49:45	89,20
20:49:50	89,20
20:49:55	89,20
20:50:00	89,10
20:50:05	89,20
20:50:10	89,20
20:50:15	89,20
20:50:20	89,30
20:50:25	89,30
20:50:30	89,40
20:50:35	89,40
20:50:40	89,40
20:50:45	89,40
20:50:50	89,40
20:50:55	89,40
20:51:00	89,40
20:51:05	89,40
20:51:10	89,40
20:51:15	89,40
20:51:20	89,40
20:51:25	89,40
20:51:30	89,40
20:51:35	89,40
20:51:40	89,40
20:51:45	89,40
20:51:50	89,40
20:51:55	89,40
20:52:00	89,40
20:52:05	89,40
20:52:10	89,40
20:52:15	89,40
20:52:20	89,40
20:52:25	89,40
20:52:30	89,40
20:52:35	89,40
20:52:40	89,40
20:52:45	89,40
20:52:50	89,40
20:52:55	89,40
20:53:00	89,40
20:53:05	89,40
20:53:10	89,40
20:53:15	89,40
20:53:20	89,40
20:53:25	89,40
20:53:30	89,40
20:53:35	89,40
20:53:40	89,40
20:53:45	89,40
20:53:50	89,60
20:53:55	89,60
20:54:00	89,60
20:54:05	89,60

20:54:10	89,70
20:54:15	89,70
20:54:20	89,70
20:54:25	89,70
20:54:30	89,70
20:54:35	89,70
20:54:40	89,70
20:54:45	89,70
20:54:50	89,60
20:54:55	89,60
20:55:00	89,60
20:55:05	89,60
20:55:10	89,60
20:55:15	89,60
20:55:20	89,60
20:55:25	89,60
20:55:30	89,70
20:55:35	89,70
20:55:40	89,70
20:55:45	89,70
20:55:50	89,70
20:55:55	89,70
20:56:00	89,70
20:56:05	89,70
20:56:10	89,80
20:56:15	89,80
20:56:20	89,80
20:56:25	89,80
20:56:30	89,80
20:56:35	89,80
20:56:40	89,80
20:56:45	89,80
20:56:50	89,70
20:56:55	89,70
20:57:00	89,70
20:57:05	89,70
20:57:10	89,60
20:57:15	89,60
20:57:20	89,60
20:57:25	89,60
20:57:30	89,60
20:57:35	89,60
20:57:40	89,60
20:57:45	89,60
20:57:50	89,60
20:57:55	89,60
20:58:00	89,60
20:58:05	89,60
20:58:10	89,60
20:58:15	89,60
20:58:20	89,60
20:58:25	89,60
20:58:30	89,60
20:58:35	89,60
20:58:40	89,40
20:58:45	89,40
20:58:50	89,40
20:58:55	89,40
20:59:00	89,40
20:59:05	89,40
20:59:10	89,40
20:59:15	89,40
20:59:20	89,40
20:59:25	89,40
20:59:30	89,40
20:59:35	89,40
20:59:40	89,40
20:59:45	89,40
20:59:50	89,40
20:59:55	89,40
21:00:00	89,40
21:00:05	89,40
21:00:10	89,40
21:00:15	89,40
21:00:20	89,40
21:00:25	89,40
21:00:30	89,60
21:00:35	89,60
21:00:40	89,60
21:00:45	89,70
21:00:50	89,70
21:00:55	89,70
21:01:00	89,70
21:01:05	89,70
21:01:10	89,70
21:01:15	89,70
21:01:20	89,70
21:01:25	89,60
21:01:30	89,60
21:01:35	89,60
21:01:40	89,40
21:01:45	89,40
21:01:50	89,40
21:01:55	89,40
21:02:00	89,40
21:02:05	89,40
21:02:10	89,40
21:02:15	89,40

21:02:20	89,40
21:02:25	89,40
21:02:30	89,40
21:02:35	89,40
21:02:40	89,60
21:02:45	89,60
21:02:50	89,70
21:02:55	89,70
21:03:00	89,70
21:03:05	89,70
21:03:10	89,70
21:03:15	89,70
21:03:20	89,70
21:03:25	89,70
21:03:30	89,70
21:03:35	89,70
21:03:40	89,70
21:03:45	89,70
21:03:50	89,70
21:03:55	89,70
21:04:00	89,70
21:04:05	89,70
21:04:10	89,70
21:04:15	89,70
21:04:20	89,70
21:04:25	89,70
21:04:30	89,70
21:04:35	89,70
21:04:40	89,70
21:04:45	89,70
21:04:50	89,70
21:04:55	89,70
21:05:00	89,70
21:05:05	89,70
21:05:10	89,70
21:05:15	89,70
21:05:20	89,70
21:05:25	89,70
21:05:30	89,70
21:05:35	89,70
21:05:40	89,70
21:05:45	89,70
21:05:50	89,70
21:05:55	89,70
21:06:00	89,70
21:06:05	89,70
21:06:10	89,70
21:06:15	89,70
21:06:20	89,70
21:06:25	89,70
21:06:30	89,70
21:06:35	89,70
21:06:40	89,60
21:06:45	89,60
21:06:50	89,60
21:06:55	89,60
21:07:00	89,60
21:07:05	89,60
21:07:10	89,60
21:07:15	89,60
21:07:20	89,70
21:07:25	89,70
21:07:30	89,70
21:07:35	89,70
21:07:40	89,70
21:07:45	89,70
21:07:50	89,70
21:07:55	89,70
21:08:00	89,70
21:08:05	89,70
21:08:10	89,70
21:08:15	89,70
21:08:20	89,70
21:08:25	89,70
21:08:30	89,70
21:08:35	89,70
21:08:40	89,70
21:08:45	89,70
21:08:50	89,70
21:08:55	89,70
21:09:00	89,70
21:09:05	89,80
21:09:10	89,80
21:09:15	89,80
21:09:20	89,80
21:09:25	89,70
21:09:30	89,70
21:09:35	89,70
21:09:40	89,70
21:09:45	89,70
21:09:50	89,70
21:09:55	89,70
21:10:00	89,70
21:10:05	89,70
21:10:10	89,70
21:10:15	89,70
21:10:20	89,70
21:10:25	89,70

21:10:30	89,70
21:10:35	89,70
21:10:40	89,70
21:10:45	89,70
21:10:50	89,70
21:10:55	89,80
21:11:00	89,80
21:11:05	89,70
21:11:10	89,70
21:11:15	89,70
21:11:20	89,70
21:11:25	89,70
21:11:30	89,70
21:11:35	89,70
21:11:40	89,70
21:11:45	89,70
21:11:50	89,70
21:11:55	89,70
21:12:00	89,60
21:12:05	89,60
21:12:10	89,60
21:12:15	89,60
21:12:20	89,60
21:12:25	89,60
21:12:30	89,60
21:12:35	89,60
21:12:40	89,60
21:12:45	89,60
21:12:50	89,60
21:12:55	89,60
21:13:00	89,60
21:13:05	89,60
21:13:10	89,60
21:13:15	89,60
21:13:20	89,70
21:13:25	89,70
21:13:30	89,70
21:13:35	89,70
21:13:40	89,70
21:13:45	89,70
21:13:50	89,70
21:13:55	89,70
21:14:00	89,70
21:14:05	89,70
21:14:10	89,70
21:14:15	89,70
21:14:20	89,70
21:14:25	89,70
21:14:30	89,70
21:14:35	89,70
21:14:40	89,60
21:14:45	89,60
21:14:50	89,60
21:14:55	89,60
21:15:00	89,60
21:15:05	89,60
21:15:10	89,60
21:15:15	89,60
21:15:20	89,60
21:15:25	89,70
21:15:30	89,70
21:15:35	89,70
21:15:40	89,70
21:15:45	89,70
21:15:50	89,70
21:15:55	89,70
21:16:00	89,60
21:16:05	89,60
21:16:10	89,60
21:16:15	89,60
21:16:20	89,60
21:16:25	89,60
21:16:30	89,60
21:16:35	89,60
21:16:40	89,60
21:16:45	89,70
21:16:50	89,70
21:16:55	89,70
21:17:00	89,70
21:17:05	89,70
21:17:10	89,70
21:17:15	89,70
21:17:20	89,70
21:17:25	89,70
21:17:30	89,70
21:17:35	89,70
21:17:40	89,70
21:17:45	89,70
21:17:50	89,70
21:17:55	89,70
21:18:00	89,70
21:18:05	89,70
21:18:10	89,70
21:18:15	89,70
21:18:20	89,70
21:18:25	89,60
21:18:30	89,60
21:18:35	89,60

21:18:40	89,60
21:18:45	89,60
21:18:50	89,60
21:18:55	89,60
21:19:00	89,40
21:19:05	89,40
21:19:10	89,40
21:19:15	89,40
21:19:20	89,40
21:19:25	89,40
21:19:30	89,40
21:19:35	89,40
21:19:40	89,40
21:19:45	89,60
21:19:50	89,60
21:19:55	89,60
21:20:00	89,60
21:20:05	89,60
21:20:10	89,60
21:20:15	89,60
21:20:20	89,60
21:20:25	89,60
21:20:30	89,60
21:20:35	89,60
21:20:40	89,60
21:20:45	89,60
21:20:50	89,60
21:20:55	89,70
21:21:00	89,70
21:21:05	89,70
21:21:10	89,70
21:21:15	89,70
21:21:20	89,70
21:21:25	89,70
21:21:30	89,70
21:21:35	89,70
21:21:40	89,70
21:21:45	89,70
21:21:50	89,80
21:21:55	89,80
21:22:00	89,80
21:22:05	89,80
21:22:10	89,80
21:22:15	89,80
21:22:20	89,80
21:22:25	89,80
21:22:30	89,70
21:22:35	89,70
21:22:40	89,70
21:22:45	89,70
21:22:50	89,70
21:22:55	89,70
21:23:00	89,70
21:23:05	89,70
21:23:10	89,70
21:23:15	89,70
21:23:20	89,70
21:23:25	89,70
21:23:30	89,70
21:23:35	89,70
21:23:40	89,80
21:23:45	89,80
21:23:50	89,80
21:23:55	89,80
21:24:00	89,80
21:24:05	89,80
21:24:10	89,80
21:24:15	89,80
21:24:20	89,80
21:24:25	89,80
21:24:30	89,80
21:24:35	89,80
21:24:40	89,70
21:24:45	89,70
21:24:50	89,80
21:24:55	89,80
21:25:00	89,80
21:25:05	89,70
21:25:10	89,70
21:25:15	89,80
21:25:20	89,80
21:25:25	89,80
21:25:30	89,80
21:25:35	89,80
21:25:40	89,80
21:25:45	89,80
21:25:50	89,80
21:25:55	89,80
21:26:00	89,70
21:26:05	89,70
21:26:10	89,70
21:26:15	89,70
21:26:20	89,70
21:26:25	89,70
21:26:30	89,80
21:26:35	89,80
21:26:40	89,80
21:26:45	89,70

21:26:50	89,70
21:26:55	89,70
21:27:00	89,70
21:27:05	89,70
21:27:10	89,70
21:27:15	89,70
21:27:20	89,70
21:27:25	89,70
21:27:30	89,70
21:27:35	89,70
21:27:40	89,70
21:27:45	89,70
21:27:50	89,70
21:27:55	89,70
21:28:00	89,70
21:28:05	89,70
21:28:10	89,70
21:28:15	89,70
21:28:20	89,70
21:28:25	89,70
21:28:30	89,70
21:28:35	89,70
21:28:40	89,60
21:28:45	89,60
21:28:50	89,60
21:28:55	89,60
21:29:00	89,60
21:29:05	89,60
21:29:10	89,60
21:29:15	89,60
21:29:20	89,60
21:29:25	89,60
21:29:30	89,60
21:29:35	89,60
21:29:40	89,60
21:29:45	89,40
21:29:50	89,40
21:29:55	89,40
21:30:00	89,40
21:30:05	89,40
21:30:10	89,40
21:30:15	89,40
21:30:20	89,40
21:30:25	89,40
21:30:30	89,40
21:30:35	89,40
21:30:40	89,40
21:30:45	89,40
21:30:50	89,40
21:30:55	89,40
21:31:00	89,40
21:31:05	89,40
21:31:10	89,40
21:31:15	89,40
21:31:20	89,40
21:31:25	89,40
21:31:30	89,40
21:31:35	89,40
21:31:40	89,40
21:31:45	89,40
21:31:50	89,40
21:31:55	89,40
21:32:00	89,40
21:32:05	89,40
21:32:10	89,40
21:32:15	89,40
21:32:20	89,40
21:32:25	89,40
21:32:30	89,40
21:32:35	89,40
21:32:40	89,40
21:32:45	89,40
21:32:50	89,40
21:32:55	89,40
21:33:00	89,40
21:33:05	89,40
21:33:10	89,40
21:33:15	89,40
21:33:20	89,40
21:33:25	89,40
21:33:30	89,40
21:33:35	89,40
21:33:40	89,40
21:33:45	89,40
21:33:50	89,40
21:33:55	89,40
21:34:00	89,40
21:34:05	89,40
21:34:10	89,40
21:34:15	89,40
21:34:20	89,40
21:34:25	89,40
21:34:30	89,40
21:34:35	89,40
21:34:40	89,40
21:34:45	89,30
21:34:50	89,30
21:34:55	89,30

21:35:00	89,30
21:35:05	89,30
21:35:10	89,40
21:35:15	89,40
21:35:20	89,40
21:35:25	89,40
21:35:30	89,40
21:35:35	89,40
21:35:40	89,40
21:35:45	89,40
21:35:50	89,40
21:35:55	89,40
21:36:00	89,40
21:36:05	89,40
21:36:10	89,40
21:36:15	89,40
21:36:20	89,40
21:36:25	89,40
21:36:30	89,40
21:36:35	89,40
21:36:40	89,40
21:36:45	89,40
21:36:50	89,40
21:36:55	89,40
21:37:00	89,40
21:37:05	89,40
21:37:10	89,40
21:37:15	89,40
21:37:20	89,40
21:37:25	89,60
21:37:30	89,60
21:37:35	89,60
21:37:40	89,60
21:37:45	89,60
21:37:50	89,60
21:37:55	89,60
21:38:00	89,60
21:38:05	89,60
21:38:10	89,60
21:38:15	89,60
21:38:20	89,60
21:38:25	89,70
21:38:30	89,70
21:38:35	89,70
21:38:40	89,70
21:38:45	89,70
21:38:50	89,70
21:38:55	89,70
21:39:00	89,70
21:39:05	89,70
21:39:10	89,70
21:39:15	89,70
21:39:20	89,70
21:39:25	89,70
21:39:30	89,70
21:39:35	89,70
21:39:40	89,70
21:39:45	89,70
21:39:50	89,70
21:39:55	89,70
21:40:00	89,70
21:40:05	89,60
21:40:10	89,60
21:40:15	89,70
21:40:20	89,70
21:40:25	89,70
21:40:30	89,70
21:40:35	89,70
21:40:40	89,70
21:40:45	89,70
21:40:50	89,70
21:40:55	89,70
21:41:00	89,70
21:41:05	89,70
21:41:10	89,70
21:41:15	89,70
21:41:20	89,70
21:41:25	89,70
21:41:30	89,60
21:41:35	89,60
21:41:40	89,60
21:41:45	89,60
21:41:50	89,60
21:41:55	89,60
21:42:00	89,60
21:42:05	89,60
21:42:10	89,60
21:42:15	89,60
21:42:20	89,60
21:42:25	89,60
21:42:30	89,70
21:42:35	89,70
21:42:40	89,70
21:42:45	89,70
21:42:50	89,70
21:42:55	89,70
21:43:00	89,70
21:43:05	89,70

21:43:10	89,70
21:43:15	89,70
21:43:20	89,70
21:43:25	89,70
21:43:30	89,70
21:43:35	89,70
21:43:40	89,70
21:43:45	89,70
21:43:50	89,70
21:43:55	89,70
21:44:00	89,70
21:44:05	89,70
21:44:10	89,70
21:44:15	89,70
21:44:20	89,70
21:44:25	89,70
21:44:30	89,70
21:44:35	89,70
21:44:40	89,70
21:44:45	89,70
21:44:50	89,70
21:44:55	89,70
21:45:00	89,70
21:45:05	89,70
21:45:10	89,70
21:45:15	89,70
21:45:20	89,70
21:45:25	89,60
21:45:30	89,60
21:45:35	89,60
21:45:40	89,60
21:45:45	89,60
21:45:50	89,60
21:45:55	89,60
21:46:00	89,60
21:46:05	89,60
21:46:10	89,60
21:46:15	89,60
21:46:20	89,60
21:46:25	89,60
21:46:30	89,60
21:46:35	89,60
21:46:40	89,60
21:46:45	89,60
21:46:50	89,60
21:46:55	89,60
21:47:00	89,60
21:47:05	89,60
21:47:10	89,60
21:47:15	89,60
21:47:20	89,60
21:47:25	89,60
21:47:30	89,60
21:47:35	89,60
21:47:40	89,60
21:47:45	89,60
21:47:50	89,60
21:47:55	89,60
21:48:00	89,40
21:48:05	89,40
21:48:10	89,40
21:48:15	89,40
21:48:20	89,40
21:48:25	89,40
21:48:30	89,60
21:48:35	89,60
21:48:40	89,60
21:48:45	89,60
21:48:50	89,60
21:48:55	89,60
21:49:00	89,60
21:49:05	89,60
21:49:10	89,60
21:49:15	89,60
21:49:20	89,60
21:49:25	89,60
21:49:30	89,60
21:49:35	89,60
21:49:40	89,60
21:49:45	89,60
21:49:50	89,60
21:49:55	89,40
21:50:00	89,40
21:50:05	89,40
21:50:10	89,40
21:50:15	89,40
21:50:20	89,40
21:50:25	89,40
21:50:30	89,40
21:50:35	89,40
21:50:40	89,40
21:50:45	89,40
21:50:50	89,40
21:50:55	89,40
21:51:00	89,40
21:51:05	89,40
21:51:10	89,40
21:51:15	89,40

21:51:20	89,40
21:51:25	89,40
21:51:30	89,40
21:51:35	89,40
21:51:40	89,40
21:51:45	89,40
21:51:50	89,60
21:51:55	89,60
21:52:00	89,60
21:52:05	89,60
21:52:10	89,60
21:52:15	89,60
21:52:20	89,60
21:52:25	89,60
21:52:30	89,40
21:52:35	89,40
21:52:40	89,40
21:52:45	89,40
21:52:50	89,40
21:52:55	89,40
21:53:00	89,40
21:53:05	89,40
21:53:10	89,60
21:53:15	89,60
21:53:20	89,60
21:53:25	89,60
21:53:30	89,70
21:53:35	89,70
21:53:40	89,70
21:53:45	89,70
21:53:50	89,70
21:53:55	89,70
21:54:00	89,70
21:54:05	89,70
21:54:10	89,70
21:54:15	89,70
21:54:20	89,70
21:54:25	89,70
21:54:30	89,70
21:54:35	89,70
21:54:40	89,70
21:54:45	89,70
21:54:50	89,70
21:54:55	89,70
21:55:00	89,70
21:55:05	89,70
21:55:10	89,70
21:55:15	89,70
21:55:20	89,70
21:55:25	89,70
21:55:30	89,70
21:55:35	89,70
21:55:40	89,70
21:55:45	89,70
21:55:50	89,70
21:55:55	89,70
21:56:00	89,70
21:56:05	89,70
21:56:10	89,70
21:56:15	89,70
21:56:20	89,70
21:56:25	89,70
21:56:30	89,70
21:56:35	89,70
21:56:40	89,70
21:56:45	89,70
21:56:50	89,70
21:56:55	89,70
21:57:00	89,70
21:57:05	89,70
21:57:10	89,70
21:57:15	89,70
21:57:20	89,70
21:57:25	89,70
21:57:30	89,70
21:57:35	89,70
21:57:40	89,70
21:57:45	89,70
21:57:50	89,70
21:57:55	89,70
21:58:00	89,70
21:58:05	89,70
21:58:10	89,70
21:58:15	89,70
21:58:20	89,70
21:58:25	89,70
21:58:30	89,70
21:58:35	89,70
21:58:40	89,70
21:58:45	89,70
21:58:50	89,70
21:58:55	89,70
21:59:00	89,70
21:59:05	89,70
21:59:10	89,70
21:59:15	89,70
21:59:20	89,70
21:59:25	89,70

21:59:30	89,70
21:59:35	89,70
21:59:40	89,70
21:59:45	89,70
21:59:50	89,70
21:59:55	89,70
22:00:00	89,70
22:00:05	89,70
22:00:10	89,70
22:00:15	89,70
22:00:20	89,70
22:00:25	89,70
22:00:30	89,70
22:00:35	89,70
22:00:40	89,70
22:00:45	89,70
22:00:50	89,70
22:00:55	89,70
22:01:00	89,70
22:01:05	89,70
22:01:10	89,70
22:01:15	89,70
22:01:20	89,70
22:01:25	89,70
22:01:30	89,70
22:01:35	89,70
22:01:40	89,70
22:01:45	89,70
22:01:50	89,80
22:01:55	89,80
22:02:00	89,80
22:02:05	89,80
22:02:10	89,80
22:02:15	89,80
22:02:20	89,80
22:02:25	89,80
22:02:30	89,80
22:02:35	89,80
22:02:40	89,80
22:02:45	89,80
22:02:50	89,80
22:02:55	89,80
22:03:00	89,80
22:03:05	89,80
22:03:10	89,80
22:03:15	89,80
22:03:20	89,80
22:03:25	89,80
22:03:30	89,70
22:03:35	89,70
22:03:40	89,70
22:03:45	89,70
22:03:50	89,70
22:03:55	89,70
22:04:00	89,70
22:04:05	89,70
22:04:10	89,70
22:04:15	89,70
22:04:20	89,70
22:04:25	89,70
22:04:30	89,70
22:04:35	89,70
22:04:40	89,70
22:04:45	89,70
22:04:50	89,70
22:04:55	89,70
22:05:00	89,70
22:05:05	89,70
22:05:10	89,70
22:05:15	89,70
22:05:20	89,70
22:05:25	89,70
22:05:30	89,70
22:05:35	89,70
22:05:40	89,70
22:05:45	89,60
22:05:50	89,70
22:05:55	89,70
22:06:00	89,70
22:06:05	89,70
22:06:10	89,70
22:06:15	89,70
22:06:20	89,70
22:06:25	89,70
22:06:30	89,70
22:06:35	89,70
22:06:40	89,70
22:06:45	89,70
22:06:50	89,70
22:06:55	89,70
22:07:00	89,70
22:07:05	89,70
22:07:10	89,70
22:07:15	89,70
22:07:20	89,70
22:07:25	89,70
22:07:30	89,70
22:07:35	89,70

22:07:40	89,60
22:07:45	89,60
22:07:50	89,60
22:07:55	89,60
22:08:00	89,60
22:08:05	89,60
22:08:10	89,60
22:08:15	89,60
22:08:20	89,60
22:08:25	89,60
22:08:30	89,60
22:08:35	89,40
22:08:40	89,40
22:08:45	89,40
22:08:50	89,40
22:08:55	89,40
22:09:00	89,40
22:09:05	89,40
22:09:10	89,40
22:09:15	89,40
22:09:20	89,40
22:09:25	89,40
22:09:30	89,40
22:09:35	89,40
22:09:40	89,40
22:09:45	89,40
22:09:50	89,40
22:09:55	89,40
22:10:00	89,40
22:10:05	89,40
22:10:10	89,40
22:10:15	89,40
22:10:20	89,40
22:10:25	89,40
22:10:30	89,40
22:10:35	89,40
22:10:40	89,40
22:10:45	89,40
22:10:50	89,40
22:10:55	89,40
22:11:00	89,40
22:11:05	89,40
22:11:10	89,40
22:11:15	89,40
22:11:20	89,40
22:11:25	89,40
22:11:30	89,40
22:11:35	89,40
22:11:40	89,40
22:11:45	89,40
22:11:50	89,40
22:11:55	89,40
22:12:00	89,40
22:12:05	89,60
22:12:10	89,60
22:12:15	89,60
22:12:20	89,60
22:12:25	89,60
22:12:30	89,60
22:12:35	89,60
22:12:40	89,60
22:12:45	89,50
22:12:50	89,40
22:12:55	89,40
22:13:00	89,40
22:13:05	89,40
22:13:10	89,40
22:13:15	89,40
22:13:20	89,60
22:13:25	89,40
22:13:30	89,60
22:13:35	89,60
22:13:40	89,60
22:13:45	89,60
22:13:50	89,60
22:13:55	89,60
22:14:00	89,60
22:14:05	89,60
22:14:10	89,60
22:14:15	89,60
22:14:20	89,60
22:14:25	89,40
22:14:30	89,40
22:14:35	89,40
22:14:40	89,40
22:14:45	89,40
22:14:50	89,40
22:14:55	89,40
22:15:00	89,40
22:15:05	89,40
22:15:10	89,40
22:15:15	89,40
22:15:20	89,40
22:15:25	89,40
22:15:30	89,40
22:15:35	89,40
22:15:40	89,40
22:15:45	89,40

22:15:50	89,40
22:15:55	89,40
22:16:00	89,40
22:16:05	89,40
22:16:10	89,60
22:16:15	89,60
22:16:20	89,60
22:16:25	89,60
22:16:30	89,60
22:16:35	89,70
22:16:40	89,70
22:16:45	89,70
22:16:50	89,70
22:16:55	89,70
22:17:00	89,70
22:17:05	89,70
22:17:10	89,70
22:17:15	89,60
22:17:20	89,60
22:17:25	89,60
22:17:30	89,60
22:17:35	89,60
22:17:40	89,60
22:17:45	89,70
22:17:50	89,70
22:17:55	89,70
22:18:00	89,70
22:18:05	89,70
22:18:10	89,70
22:18:15	89,70
22:18:20	89,70
22:18:25	89,70
22:18:30	89,70
22:18:35	89,70
22:18:40	89,70
22:18:45	89,70
22:18:50	89,70
22:18:55	89,70
22:19:00	89,70
22:19:05	89,70
22:19:10	89,70
22:19:15	89,70
22:19:20	89,70
22:19:25	89,70
22:19:30	89,70
22:19:35	89,70
22:19:40	89,70
22:19:45	89,70
22:19:50	89,70
22:19:55	89,70
22:20:00	89,70
22:20:05	89,70
22:20:10	89,70
22:20:15	89,70
22:20:20	89,70
22:20:25	89,70
22:20:30	89,70
22:20:35	89,70
22:20:40	89,70
22:20:45	89,70
22:20:50	89,70
22:20:55	89,70
22:21:00	89,70
22:21:05	89,70
22:21:10	89,70
22:21:15	89,70
22:21:20	89,70
22:21:25	89,70
22:21:30	89,70
22:21:35	89,70
22:21:40	89,70
22:21:45	89,70
22:21:50	89,70
22:21:55	89,80
22:22:00	89,80
22:22:05	89,80
22:22:10	89,70
22:22:15	89,70
22:22:20	89,70
22:22:25	89,70
22:22:30	89,70
22:22:35	89,70
22:22:40	89,70
22:22:45	89,70
22:22:50	89,70
22:22:55	89,60
22:23:00	89,60
22:23:05	89,60
22:23:10	89,60
22:23:15	89,60
22:23:20	89,60
22:23:25	89,60
22:23:30	89,60
22:23:35	89,60
22:23:40	89,60
22:23:45	89,60
22:23:50	89,60
22:23:55	89,60

22:24:00	89,70
22:24:05	89,70
22:24:10	89,70
22:24:15	89,70
22:24:20	89,80
22:24:25	89,80
22:24:30	89,80
22:24:35	89,80
22:24:40	89,80
22:24:45	89,70
22:24:50	89,70
22:24:55	89,70
22:25:00	89,70
22:25:05	89,60
22:25:10	89,40
22:25:15	89,40
22:25:20	89,40
22:25:25	89,40
22:25:30	89,40
22:25:35	89,40
22:25:40	89,40
22:25:45	89,40
22:25:50	89,60
22:25:55	89,70
22:26:00	89,70
22:26:05	89,70
22:26:10	89,70
22:26:15	89,80
22:26:20	89,80
22:26:25	89,80
22:26:30	89,80
22:26:35	89,80
22:26:40	89,80
22:26:45	89,70
22:26:50	89,70
22:26:55	89,70
22:27:00	89,70
22:27:05	89,70
22:27:10	89,70
22:27:15	89,70
22:27:20	89,60
22:27:25	89,40
22:27:30	89,40
22:27:35	89,40
22:27:40	89,40
22:27:45	89,40
22:27:50	89,40
22:27:55	89,40
22:28:00	89,40
22:28:05	89,40
22:28:10	89,40
22:28:15	89,40
22:28:20	89,60
22:28:25	89,60
22:28:30	89,60
22:28:35	89,60
22:28:40	89,40
22:28:45	89,40
22:28:50	89,40
22:28:55	89,40
22:29:00	89,40
22:29:05	89,40
22:29:10	89,40
22:29:15	89,40
22:29:20	89,40
22:29:25	89,40
22:29:30	89,40
22:29:35	89,40
22:29:40	89,40
22:29:45	89,40
22:29:50	89,40
22:29:55	89,40
22:30:00	89,40
22:30:05	89,40
22:30:10	89,40
22:30:15	89,40
22:30:20	89,40
22:30:25	89,40
22:30:30	89,40
22:30:35	89,40
22:30:40	89,40
22:30:45	89,40
22:30:50	89,40
22:30:55	89,30
22:31:00	89,30
22:31:05	89,30
22:31:10	89,30
22:31:15	89,30
22:31:20	89,30
22:31:25	89,30
22:31:30	89,30
22:31:35	89,40
22:31:40	89,40
22:31:45	89,40
22:31:50	89,40
22:31:55	89,40
22:32:00	89,40
22:32:05	89,40

22:32:10	89,40
22:32:15	89,40
22:32:20	89,40
22:32:25	89,40
22:32:30	89,40
22:32:35	89,40
22:32:40	89,40
22:32:45	89,40
22:32:50	89,40
22:32:55	89,40
22:33:00	89,40
22:33:05	89,40
22:33:10	89,40
22:33:15	89,40
22:33:20	89,40
22:33:25	89,40
22:33:30	89,40
22:33:35	89,40
22:33:40	89,40
22:33:45	89,40
22:33:50	89,40
22:33:55	89,40
22:34:00	89,40
22:34:05	89,40
22:34:10	89,40
22:34:15	89,40
22:34:20	89,40
22:34:25	89,40
22:34:30	89,40
22:34:35	89,40
22:34:40	89,40
22:34:45	89,40
22:34:50	89,40
22:34:55	89,40
22:35:00	89,40
22:35:05	89,40
22:35:10	89,40
22:35:15	89,40
22:35:20	89,40
22:35:25	89,40
22:35:30	89,40
22:35:35	89,40
22:35:40	89,60
22:35:45	89,60
22:35:50	89,60
22:35:55	89,70
22:36:00	89,70
22:36:05	89,70
22:36:10	89,70
22:36:15	89,70
22:36:20	89,70
22:36:25	89,70
22:36:30	89,70
22:36:35	89,70
22:36:40	89,70
22:36:45	89,60
22:36:50	89,60
22:36:55	89,60
22:37:00	89,60
22:37:05	89,60
22:37:10	89,60
22:37:15	89,60
22:37:20	89,60
22:37:25	89,60
22:37:30	89,60
22:37:35	89,60
22:37:40	89,60
22:37:45	89,60
22:37:50	89,60
22:37:55	89,70
22:38:00	89,70
22:38:05	89,70
22:38:10	89,70
22:38:15	89,70
22:38:20	89,70
22:38:25	89,70
22:38:30	89,70
22:38:35	89,70
22:38:40	89,80
22:38:45	89,80
22:38:50	89,80
22:38:55	89,80
22:39:00	89,90
22:39:05	89,90
22:39:10	89,90
22:39:15	89,90
22:39:20	89,90
22:39:25	89,90
22:39:30	89,80
22:39:35	89,80
22:39:40	89,80
22:39:45	89,80
22:39:50	89,80
22:39:55	89,80
22:40:00	89,70
22:40:05	89,70
22:40:10	89,70
22:40:15	89,80

22:40:20	89,80
22:40:25	89,80
22:40:30	89,80
22:40:35	89,80
22:40:40	89,80
22:40:45	89,80
22:40:50	89,80
22:40:55	89,80
22:41:00	89,80
22:41:05	89,70
22:41:10	89,70
22:41:15	89,70
22:41:20	89,70
22:41:25	89,70
22:41:30	89,70
22:41:35	89,70
22:41:40	89,70
22:41:45	89,70
22:41:50	89,70
22:41:55	89,70
22:42:00	89,70
22:42:05	89,70
22:42:10	89,70
22:42:15	89,70
22:42:20	89,70
22:42:25	89,70
22:42:30	89,70
22:42:35	89,70
22:42:40	89,70
22:42:45	89,70
22:42:50	89,70
22:42:55	89,70
22:43:00	89,70
22:43:05	89,70
22:43:10	89,70
22:43:15	89,70
22:43:20	89,70
22:43:25	89,70
22:43:30	89,60
22:43:35	89,60
22:43:40	89,60
22:43:45	89,60
22:43:50	89,60
22:43:55	89,60
22:44:00	89,60
22:44:05	89,60
22:44:10	89,60
22:44:15	89,60
22:44:20	89,60
22:44:25	89,60
22:44:30	89,60
22:44:35	89,60
22:44:40	89,40
22:44:45	89,40
22:44:50	89,60
22:44:55	89,60
22:45:00	89,60
22:45:05	89,60
22:45:10	89,60
22:45:15	89,60
22:45:20	89,60
22:45:25	89,40
22:45:30	89,40
22:45:35	89,40
22:45:40	89,40
22:45:45	89,40
22:45:50	89,40
22:45:55	89,40
22:46:00	89,40
22:46:05	89,40
22:46:10	89,40
22:46:15	89,30
22:46:20	89,30
22:46:25	89,30
22:46:30	89,40
22:46:35	89,40
22:46:40	89,40
22:46:45	89,40
22:46:50	89,40
22:46:55	89,40
22:47:00	89,60
22:47:05	89,60
22:47:10	89,60
22:47:15	89,60
22:47:20	89,70
22:47:25	89,70
22:47:30	89,70
22:47:35	89,70
22:47:40	89,70
22:47:45	89,70
22:47:50	89,70
22:47:55	89,60
22:48:00	89,60
22:48:05	89,60
22:48:10	89,40
22:48:15	89,40
22:48:20	89,40
22:48:25	89,40

22:48:30	89,40
22:48:35	89,40
22:48:40	89,40
22:48:45	89,40
22:48:50	89,50
22:48:55	89,50
22:49:00	89,40
22:49:05	89,40
22:49:10	89,40
22:49:15	89,40
22:49:20	89,40
22:49:25	89,40
22:49:30	89,40
22:49:35	89,40
22:49:40	89,40
22:49:45	89,40
22:49:50	89,40
22:49:55	89,40
22:50:00	89,40
22:50:05	89,40
22:50:10	89,40
22:50:15	89,40
22:50:20	89,40
22:50:25	89,40
22:50:30	89,40
22:50:35	89,40
22:50:40	89,40
22:50:45	89,40
22:50:50	89,40
22:50:55	89,60
22:51:00	89,60
22:51:05	89,60
22:51:10	89,60
22:51:15	89,60
22:51:20	89,60
22:51:25	89,60
22:51:30	89,60
22:51:35	89,60
22:51:40	89,70
22:51:45	89,60
22:51:50	89,60
22:51:55	89,60
22:52:00	89,60
22:52:05	89,60
22:52:10	89,60
22:52:15	89,60
22:52:20	89,60
22:52:25	89,60
22:52:30	89,60
22:52:35	89,60
22:52:40	89,60
22:52:45	89,60
22:52:50	89,60
22:52:55	89,60
22:53:00	89,60
22:53:05	89,60
22:53:10	89,60
22:53:15	89,60
22:53:20	89,60
22:53:25	89,60
22:53:30	89,60
22:53:35	89,60
22:53:40	89,60
22:53:45	89,60
22:53:50	89,40
22:53:55	89,40
22:54:00	89,40
22:54:05	89,40
22:54:10	89,40
22:54:15	89,40
22:54:20	89,40
22:54:25	89,40
22:54:30	89,40
22:54:35	89,40
22:54:40	89,40
22:54:45	89,40
22:54:50	89,40
22:54:55	89,40
22:55:00	89,40
22:55:05	89,40
22:55:10	89,40
22:55:15	89,40
22:55:20	89,40
22:55:25	89,40
22:55:30	89,40
22:55:35	89,40
22:55:40	89,40
22:55:45	89,40
22:55:50	89,40
22:55:55	89,40
22:56:00	89,40
22:56:05	89,40
22:56:10	89,40
22:56:15	89,40
22:56:20	89,40
22:56:25	89,40
22:56:30	89,40
22:56:35	89,40

22:56:40	89,40
22:56:45	89,40
22:56:50	89,40
22:56:55	89,40
22:57:00	89,40
22:57:05	89,40
22:57:10	89,40
22:57:15	89,40
22:57:20	89,40
22:57:25	89,40
22:57:30	89,40
22:57:35	89,40
22:57:40	89,40
22:57:45	89,40
22:57:50	89,40
22:57:55	89,60
22:58:00	89,60
22:58:05	89,60
22:58:10	89,60
22:58:15	89,70
22:58:20	89,70
22:58:25	89,70
22:58:30	89,70
22:58:35	89,70
22:58:40	89,70
22:58:45	89,70
22:58:50	89,70
22:58:55	89,70
22:59:00	89,70
22:59:05	89,70
22:59:10	89,70
22:59:15	89,70
22:59:20	89,70
22:59:25	89,70
22:59:30	89,60
22:59:35	89,60
22:59:40	89,60
22:59:45	89,60
22:59:50	89,60
22:59:55	89,60
23:00:00	89,60
23:00:05	89,60
23:00:10	89,60
23:00:15	89,60
23:00:20	89,60
23:00:25	89,60
23:00:30	89,60
23:00:35	89,60
23:00:40	89,60
23:00:45	89,70
23:00:50	89,70
23:00:55	89,70
23:01:00	89,70
23:01:05	89,70
23:01:10	89,70
23:01:15	89,70
23:01:20	89,70
23:01:25	89,70
23:01:30	89,70
23:01:35	89,70
23:01:40	89,70
23:01:45	89,70
23:01:50	89,70
23:01:55	89,70
23:02:00	89,70
23:02:05	89,70
23:02:10	89,70
23:02:15	89,70
23:02:20	89,70
23:02:25	89,70
23:02:30	89,60
23:02:35	89,60
23:02:40	89,60
23:02:45	89,60
23:02:50	89,70
23:02:55	89,70
23:03:00	89,70
23:03:05	89,70
23:03:10	89,60
23:03:15	89,70
23:03:20	89,60
23:03:25	89,60
23:03:30	89,60
23:03:35	89,60
23:03:40	89,60
23:03:45	89,60
23:03:50	89,60
23:03:55	89,60
23:04:00	89,60
23:04:05	89,60
23:04:10	89,60
23:04:15	89,60
23:04:20	89,60
23:04:25	89,70
23:04:30	89,70
23:04:35	89,70
23:04:40	89,70
23:04:45	89,70

23:04:50	89,70
23:04:55	89,70
23:05:00	89,70
23:05:05	89,70
23:05:10	89,70
23:05:15	89,70
23:05:20	89,70
23:05:25	89,60
23:05:30	89,60
23:05:35	89,60
23:05:40	89,60
23:05:45	89,60
23:05:50	89,60
23:05:55	89,60
23:06:00	89,60
23:06:05	89,40
23:06:10	89,40
23:06:15	89,40
23:06:20	89,40
23:06:25	89,40
23:06:30	89,40
23:06:35	89,40
23:06:40	89,40
23:06:45	89,40
23:06:50	89,40
23:06:55	89,40
23:07:00	89,40
23:07:05	89,40
23:07:10	89,40
23:07:15	89,40
23:07:20	89,40
23:07:25	89,40
23:07:30	89,40
23:07:35	89,40
23:07:40	89,40
23:07:45	89,40
23:07:50	89,40
23:07:55	89,40
23:08:00	89,40
23:08:05	89,40
23:08:10	89,40
23:08:15	89,30
23:08:20	89,30
23:08:25	89,30
23:08:30	89,30
23:08:35	89,30
23:08:40	89,30
23:08:45	89,30
23:08:50	89,30
23:08:55	89,40
23:09:00	89,40
23:09:05	89,40
23:09:10	89,40
23:09:15	89,40
23:09:20	89,40
23:09:25	89,40
23:09:30	89,40
23:09:35	89,60
23:09:40	89,60
23:09:45	89,60
23:09:50	89,60
23:09:55	89,60
23:10:00	89,50
23:10:05	89,40
23:10:10	89,40
23:10:15	89,40
23:10:20	89,40
23:10:25	89,40
23:10:30	89,40
23:10:35	89,40
23:10:40	89,40
23:10:45	89,40
23:10:50	89,40
23:10:55	89,40
23:11:00	89,40
23:11:05	89,40
23:11:10	89,40
23:11:15	89,40
23:11:20	89,40
23:11:25	89,40
23:11:30	89,40
23:11:35	89,40
23:11:40	89,40
23:11:45	89,40
23:11:50	89,40
23:11:55	89,40
23:12:00	89,40
23:12:05	89,40
23:12:10	89,40
23:12:15	89,40
23:12:20	89,40
23:12:25	89,40
23:12:30	89,40
23:12:35	89,40
23:12:40	89,40
23:12:45	89,40
23:12:50	89,40
23:12:55	89,40

23:13:00	89,40
23:13:05	89,40
23:13:10	89,40
23:13:15	89,40
23:13:20	89,40
23:13:25	89,40
23:13:30	89,40
23:13:35	89,60
23:13:40	89,60
23:13:45	89,60
23:13:50	89,60
23:13:55	89,60
23:14:00	89,60
23:14:05	89,70
23:14:10	89,70
23:14:15	89,70
23:14:20	89,70
23:14:25	89,70
23:14:30	89,70
23:14:35	89,70
23:14:40	89,70
23:14:45	89,70
23:14:50	89,70
23:14:55	89,70
23:15:00	89,70
23:15:05	89,70
23:15:10	89,70
23:15:15	89,70
23:15:20	89,70
23:15:25	89,70
23:15:30	89,70
23:15:35	89,70
23:15:40	89,70
23:15:45	89,70
23:15:50	89,70
23:15:55	89,70
23:16:00	89,70
23:16:05	89,70
23:16:10	89,70
23:16:15	89,70
23:16:20	89,70
23:16:25	89,70
23:16:30	89,70
23:16:35	89,70
23:16:40	89,70
23:16:45	89,70
23:16:50	89,80
23:16:55	89,80
23:17:00	89,80
23:17:05	89,80
23:17:10	89,80
23:17:15	89,90
23:17:20	89,90
23:17:25	89,80
23:17:30	89,80
23:17:35	89,80
23:17:40	89,80
23:17:45	89,80
23:17:50	89,80
23:17:55	89,80
23:18:00	89,80
23:18:05	89,80
23:18:10	89,70
23:18:15	89,70
23:18:20	89,70
23:18:25	89,70
23:18:30	89,70
23:18:35	89,70
23:18:40	89,70
23:18:45	89,70
23:18:50	89,70
23:18:55	89,70
23:19:00	89,70
23:19:05	89,70
23:19:10	89,70
23:19:15	89,70
23:19:20	89,80
23:19:25	89,80
23:19:30	89,80
23:19:35	89,80
23:19:40	89,80
23:19:45	89,80
23:19:50	89,90
23:19:55	89,90
23:20:00	89,90
23:20:05	89,80
23:20:10	89,80
23:20:15	89,80
23:20:20	89,70
23:20:25	89,70
23:20:30	89,70
23:20:35	89,70
23:20:40	89,70
23:20:45	89,70
23:20:50	89,60
23:20:55	89,60
23:21:00	89,60
23:21:05	89,60

23:21:10	89,60
23:21:15	89,60
23:21:20	89,40
23:21:25	89,40
23:21:30	89,40
23:21:35	89,40
23:21:40	89,40
23:21:45	89,40
23:21:50	89,40
23:21:55	89,40
23:22:00	89,40
23:22:05	89,40
23:22:10	89,40
23:22:15	89,40
23:22:20	89,40
23:22:25	89,40
23:22:30	89,40
23:22:35	89,40
23:22:40	89,40
23:22:45	89,40
23:22:50	89,40
23:22:55	89,40
23:23:00	89,40
23:23:05	89,40
23:23:10	89,40
23:23:15	89,40
23:23:20	89,40
23:23:25	89,40
23:23:30	89,40
23:23:35	89,40
23:23:40	89,40
23:23:45	89,40
23:23:50	89,40
23:23:55	89,30
23:24:00	89,30
23:24:05	89,30
23:24:10	89,30
23:24:15	89,30
23:24:20	89,30
23:24:25	89,40
23:24:30	89,40
23:24:35	89,40
23:24:40	89,40
23:24:45	89,40
23:24:50	89,40
23:24:55	89,60
23:25:00	89,50
23:25:05	89,40
23:25:10	89,40
23:25:15	89,40
23:25:20	89,40
23:25:25	89,40
23:25:30	89,40
23:25:35	89,40
23:25:40	89,40
23:25:45	89,40
23:25:50	89,40
23:25:55	89,40
23:26:00	89,40
23:26:05	89,40
23:26:10	89,60
23:26:15	89,60
23:26:20	89,60
23:26:25	89,60
23:26:30	89,60
23:26:35	89,60
23:26:40	89,60
23:26:45	89,40
23:26:50	89,40
23:26:55	89,40
23:27:00	89,40
23:27:05	89,40
23:27:10	89,40
23:27:15	89,40
23:27:20	89,40
23:27:25	89,40
23:27:30	89,40
23:27:35	89,40
23:27:40	89,40
23:27:45	89,60
23:27:50	89,60
23:27:55	89,60
23:28:00	89,60
23:28:05	89,60
23:28:10	89,60
23:28:15	89,60
23:28:20	89,70
23:28:25	89,70
23:28:30	89,70
23:28:35	89,70
23:28:40	89,70
23:28:45	89,70
23:28:50	89,70
23:28:55	89,70
23:29:00	89,70
23:29:05	89,70
23:29:10	89,70
23:29:15	89,60

23:29:20	89,60
23:29:25	89,60
23:29:30	89,60
23:29:35	89,60
23:29:40	89,60
23:29:45	89,60
23:29:50	89,60
23:29:55	89,60
23:30:00	89,60
23:30:05	89,70
23:30:10	89,70
23:30:15	89,70
23:30:20	89,70
23:30:25	89,70
23:30:30	89,70
23:30:35	89,70
23:30:40	89,70
23:30:45	89,70
23:30:50	89,70
23:30:55	89,70
23:31:00	89,70
23:31:05	89,70
23:31:10	89,70
23:31:15	89,70
23:31:20	89,70
23:31:25	89,70
23:31:30	89,70
23:31:35	89,70
23:31:40	89,70
23:31:45	89,70
23:31:50	89,70
23:31:55	89,70
23:32:00	89,70
23:32:05	89,60
23:32:10	89,60
23:32:15	89,60
23:32:20	89,60
23:32:25	89,70
23:32:30	89,70
23:32:35	89,70
23:32:40	89,70
23:32:45	89,70
23:32:50	89,70
23:32:55	89,70
23:33:00	89,70
23:33:05	89,70
23:33:10	89,70
23:33:15	89,70
23:33:20	89,70
23:33:25	89,70
23:33:30	89,70
23:33:35	89,80
23:33:40	89,80
23:33:45	89,80
23:33:50	89,80
23:33:55	89,80
23:34:00	89,80
23:34:05	89,80
23:34:10	89,70
23:34:15	89,70
23:34:20	89,70
23:34:25	89,70
23:34:30	89,70
23:34:35	89,70
23:34:40	89,70
23:34:45	89,80
23:34:50	89,80
23:34:55	89,80
23:35:00	89,80
23:35:05	89,80
23:35:10	89,80
23:35:15	89,80
23:35:20	89,80
23:35:25	89,70
23:35:30	89,70
23:35:35	89,70
23:35:40	89,70
23:35:45	89,70
23:35:50	89,70
23:35:55	89,70
23:36:00	89,70
23:36:05	89,70
23:36:10	89,70
23:36:15	89,70
23:36:20	89,70
23:36:25	89,70
23:36:30	89,70
23:36:35	89,70
23:36:40	89,70
23:36:45	89,80
23:36:50	89,80
23:36:55	89,80
23:37:00	89,90
23:37:05	89,90
23:37:10	89,90
23:37:15	89,90
23:37:20	89,90
23:37:25	89,80

23:37:30	89,80
23:37:35	89,80
23:37:40	89,80
23:37:45	89,80
23:37:50	89,80
23:37:55	89,80
23:38:00	89,80
23:38:05	89,80
23:38:10	89,80
23:38:15	89,80
23:38:20	89,80
23:38:25	89,80
23:38:30	89,80
23:38:35	89,80
23:38:40	89,70
23:38:45	89,70
23:38:50	89,70
23:38:55	89,70
23:39:00	89,70
23:39:05	89,70
23:39:10	89,70
23:39:15	89,70
23:39:20	89,70
23:39:25	89,70
23:39:30	89,70
23:39:35	89,70
23:39:40	89,70
23:39:45	89,70
23:39:50	89,70
23:39:55	89,70
23:40:00	89,70
23:40:05	89,70
23:40:10	89,70
23:40:15	89,70
23:40:20	89,70
23:40:25	89,70
23:40:30	89,70
23:40:35	89,60
23:40:40	89,60
23:40:45	89,60
23:40:50	89,60
23:40:55	89,60
23:41:00	89,60
23:41:05	89,60
23:41:10	89,60
23:41:15	89,60
23:41:20	89,60
23:41:25	89,60
23:41:30	89,60
23:41:35	89,60
23:41:40	89,60
23:41:45	89,60
23:41:50	89,60
23:41:55	89,40
23:42:00	89,40
23:42:05	89,40
23:42:10	89,40
23:42:15	89,40
23:42:20	89,40
23:42:25	89,40
23:42:30	89,40
23:42:35	89,40
23:42:40	89,40
23:42:45	89,40
23:42:50	89,40
23:42:55	89,30
23:43:00	89,30
23:43:05	89,30
23:43:10	89,30
23:43:15	89,30
23:43:20	89,40
23:43:25	89,40
23:43:30	89,40
23:43:35	89,40
23:43:40	89,40
23:43:45	89,40
23:43:50	89,40
23:43:55	89,40
23:44:00	89,40
23:44:05	89,40
23:44:10	89,40
23:44:15	89,40
23:44:20	89,40
23:44:25	89,40
23:44:30	89,40
23:44:35	89,40
23:44:40	89,40
23:44:45	89,40
23:44:50	89,40
23:44:55	89,40
23:45:00	89,40
23:45:05	89,40
23:45:10	89,40
23:45:15	89,40
23:45:20	89,40
23:45:25	89,40
23:45:30	89,40
23:45:35	89,40

23:45:40	89,40
23:45:45	89,40
23:45:50	89,40
23:45:55	89,40
23:46:00	89,40
23:46:05	89,40
23:46:10	89,40
23:46:15	89,40
23:46:20	89,40
23:46:25	89,40
23:46:30	89,40
23:46:35	89,40
23:46:40	89,40
23:46:45	89,40
23:46:50	89,40
23:46:55	89,40
23:47:00	89,40
23:47:05	89,40
23:47:10	89,40
23:47:15	89,40
23:47:20	89,40
23:47:25	89,40
23:47:30	89,40
23:47:35	89,40
23:47:40	89,40
23:47:45	89,40
23:47:50	89,40
23:47:55	89,40
23:48:00	89,40
23:48:05	89,40
23:48:10	89,40
23:48:15	89,40
23:48:20	89,40
23:48:25	89,40
23:48:30	89,40
23:48:35	89,40
23:48:40	89,40
23:48:45	89,40
23:48:50	89,40
23:48:55	89,40
23:49:00	89,40
23:49:05	89,40
23:49:10	89,40
23:49:15	89,40
23:49:20	89,40
23:49:25	89,40
23:49:30	89,40
23:49:35	89,40
23:49:40	89,40
23:49:45	89,40
23:49:50	89,40
23:49:55	89,40
23:50:00	89,40
23:50:05	89,40
23:50:10	89,40
23:50:15	89,40
23:50:20	89,40
23:50:25	89,40
23:50:30	89,40
23:50:35	89,40
23:50:40	89,40
23:50:45	89,40
23:50:50	89,40
23:50:55	89,60
23:51:00	89,60
23:51:05	89,60
23:51:10	89,60
23:51:15	89,60
23:51:20	89,60
23:51:25	89,60
23:51:30	89,60
23:51:35	89,60
23:51:40	89,60
23:51:45	89,60
23:51:50	89,60
23:51:55	89,70
23:52:00	89,70
23:52:05	89,70
23:52:10	89,70
23:52:15	89,70
23:52:20	89,70
23:52:25	89,70
23:52:30	89,70
23:52:35	89,70
23:52:40	89,70
23:52:45	89,70
23:52:50	89,70
23:52:55	89,70
23:53:00	89,70
23:53:05	89,70
23:53:10	89,80
23:53:15	89,80
23:53:20	89,80
23:53:25	89,80
23:53:30	89,90
23:53:35	89,90
23:53:40	89,90
23:53:45	89,90

23:53:50	89,90
23:53:55	89,80
23:54:00	89,80
23:54:05	89,80
23:54:10	89,70
23:54:15	89,70
23:54:20	89,70
23:54:25	89,70
23:54:30	89,70
23:54:35	89,70
23:54:40	89,70
23:54:45	89,70
23:54:50	89,70
23:54:55	89,70
23:55:00	89,70
23:55:05	89,70
23:55:10	89,70
23:55:15	89,70
23:55:20	89,70
23:55:25	89,70
23:55:30	89,70
23:55:35	89,70
23:55:40	89,70
23:55:45	89,70
23:55:50	89,70
23:55:55	89,70
23:56:00	89,70
23:56:05	89,70
23:56:10	89,70
23:56:15	89,70
23:56:20	89,70
23:56:25	89,70
23:56:30	89,70
23:56:35	89,70
23:56:40	89,70
23:56:45	89,70
23:56:50	89,70
23:56:55	89,70
23:57:00	89,70
23:57:05	89,70
23:57:10	89,70
23:57:15	89,70
23:57:20	89,70
23:57:25	89,70
23:57:30	89,70
23:57:35	89,70
23:57:40	89,70
23:57:45	89,70
23:57:50	89,70
23:57:55	89,70
23:58:00	89,70
23:58:05	89,70
23:58:10	89,70
23:58:15	89,70
23:58:20	89,70
23:58:25	89,70
23:58:30	89,70
23:58:35	89,70
23:58:40	89,70
23:58:45	89,70
23:58:50	89,70
23:58:55	89,70
23:59:00	89,70
23:59:05	89,70
23:59:10	89,70
23:59:15	89,70
23:59:20	89,70
23:59:25	89,70
23:59:30	89,70
23:59:35	89,70
23:59:40	89,70
23:59:45	89,70
23:59:50	89,70
23:59:55	89,70
00:00:00	89,70
00:00:05	89,70
00:00:10	89,70
00:00:15	89,70
00:00:20	89,70
00:00:25	89,70
00:00:30	89,70
00:00:35	89,70
00:00:40	89,70
00:00:45	89,70
00:00:50	89,70
00:00:55	89,70
00:01:00	89,70
00:01:05	89,70
00:01:10	89,70
00:01:15	89,70
00:01:20	89,70
00:01:25	89,70
00:01:30	89,70
00:01:35	89,70
00:01:40	89,70
00:01:45	89,70
00:01:50	89,70
00:01:55	89,70

00:02:00	89,70
00:02:05	89,70
00:02:10	89,70
00:02:15	89,70
00:02:20	89,70
00:02:25	89,70
00:02:30	89,70
00:02:35	89,70
00:02:40	89,70
00:02:45	89,70
00:02:50	89,70
00:02:55	89,70
00:03:00	89,70
00:03:05	89,70
00:03:10	89,70
00:03:15	89,70
00:03:20	89,70
00:03:25	89,70
00:03:30	89,70
00:03:35	89,70
00:03:40	89,70
00:03:45	89,70
00:03:50	89,70
00:03:55	89,70
00:04:00	89,70
00:04:05	89,70
00:04:10	89,70
00:04:15	89,70
00:04:20	89,70
00:04:25	89,70
00:04:30	89,70
00:04:35	89,70
00:04:40	89,70
00:04:45	89,70
00:04:50	89,70
00:04:55	89,70
00:05:00	89,70
00:05:05	89,70
00:05:10	89,70
00:05:15	89,70
00:05:20	89,70
00:05:25	89,70
00:05:30	89,70
00:05:35	89,70
00:05:40	89,70
00:05:45	89,70
00:05:50	89,70
00:05:55	89,70
00:06:00	89,70
00:06:05	89,60
00:06:10	89,60
00:06:15	89,60
00:06:20	89,60
00:06:25	89,60
00:06:30	89,60
00:06:35	89,60
00:06:40	89,70
00:06:45	89,70
00:06:50	89,70
00:06:55	89,70
00:07:00	89,70
00:07:05	89,70
00:07:10	89,70
00:07:15	89,70
00:07:20	89,70
00:07:25	89,70
00:07:30	89,70
00:07:35	89,70
00:07:40	89,70
00:07:45	89,70
00:07:50	89,70
00:07:55	89,70
00:08:00	89,70
00:08:05	89,70
00:08:10	89,70
00:08:15	89,70
00:08:20	89,70
00:08:25	89,70
00:08:30	89,70
00:08:35	89,70
00:08:40	89,70
00:08:45	89,70
00:08:50	89,70
00:08:55	89,70
00:09:00	89,70
00:09:05	89,70
00:09:10	89,70
00:09:15	89,70
00:09:20	89,70
00:09:25	89,70
00:09:30	89,70
00:09:35	89,70
00:09:40	89,70
00:09:45	89,70
00:09:50	89,70
00:09:55	89,70
00:10:00	89,70
00:10:05	89,70

00:10:10	89,70
00:10:15	89,70
00:10:20	89,80
00:10:25	89,80
00:10:30	89,80
00:10:35	89,70
00:10:40	89,70
00:10:45	89,70
00:10:50	89,70
00:10:55	89,70
00:11:00	89,70
00:11:05	89,70
00:11:10	89,70
00:11:15	89,70
00:11:20	89,70
00:11:25	89,70
00:11:30	89,70
00:11:35	89,70
00:11:40	89,70
00:11:45	89,70
00:11:50	89,70
00:11:55	89,70
00:12:00	89,70
00:12:05	89,70
00:12:10	89,70
00:12:15	89,70
00:12:20	89,70
00:12:25	89,70
00:12:30	89,70
00:12:35	89,70
00:12:40	89,70
00:12:45	89,70
00:12:50	89,70
00:12:55	89,70
00:13:00	89,60
00:13:05	89,60
00:13:10	89,60
00:13:15	89,60
00:13:20	89,60
00:13:25	89,40
00:13:30	89,40
00:13:35	89,40
00:13:40	89,40
00:13:45	89,40
00:13:50	89,40
00:13:55	89,40
00:14:00	89,40
00:14:05	89,40
00:14:10	89,40
00:14:15	89,40
00:14:20	89,40
00:14:25	89,40
00:14:30	89,40
00:14:35	89,40
00:14:40	89,40
00:14:45	89,40
00:14:50	89,40
00:14:55	89,40
00:15:00	89,40
00:15:05	89,40
00:15:10	89,40
00:15:15	89,40
00:15:20	89,40
00:15:25	89,40
00:15:30	89,40
00:15:35	89,40
00:15:40	89,40
00:15:45	89,40
00:15:50	89,40
00:15:55	89,40
00:16:00	89,40
00:16:05	89,40
00:16:10	89,40
00:16:15	89,40
00:16:20	89,40
00:16:25	89,40
00:16:30	89,40
00:16:35	89,40
00:16:40	89,40
00:16:45	89,40
00:16:50	89,40
00:16:55	89,40
00:17:00	89,40
00:17:05	89,40
00:17:10	89,40
00:17:15	89,40
00:17:20	89,40
00:17:25	89,40
00:17:30	89,40
00:17:35	89,40
00:17:40	89,40
00:17:45	89,60
00:17:50	89,60
00:17:55	89,60
00:18:00	89,60
00:18:05	89,60
00:18:10	89,70
00:18:15	89,70

00:18:20	89,70
00:18:25	89,70
00:18:30	89,70
00:18:35	89,70
00:18:40	89,70
00:18:45	89,70
00:18:50	89,70
00:18:55	89,70
00:19:00	89,70
00:19:05	89,70
00:19:10	89,70
00:19:15	89,70
00:19:20	89,80
00:19:25	89,80
00:19:30	89,80
00:19:35	89,80
00:19:40	89,80
00:19:45	89,80
00:19:50	89,70
00:19:55	89,70
00:20:00	89,70
00:20:05	89,70
00:20:10	89,70
00:20:15	89,70
00:20:20	89,70
00:20:25	89,70
00:20:30	89,70
00:20:35	89,70
00:20:40	89,70
00:20:45	89,70
00:20:50	89,70
00:20:55	89,70
00:21:00	89,70
00:21:05	89,70
00:21:10	89,70
00:21:15	89,80
00:21:20	89,80
00:21:25	89,70
00:21:30	89,70
00:21:35	89,70
00:21:40	89,80
00:21:45	89,80
00:21:50	89,80
00:21:55	89,80
00:22:00	89,70
00:22:05	89,70
00:22:10	89,70
00:22:15	89,70
00:22:20	89,70
00:22:25	89,70
00:22:30	89,70
00:22:35	89,70
00:22:40	89,70
00:22:45	89,60
00:22:50	89,60
00:22:55	89,60
00:23:00	89,60
00:23:05	89,60
00:23:10	89,40
00:23:15	89,40
00:23:20	89,40
00:23:25	89,40
00:23:30	89,40
00:23:35	89,40
00:23:40	89,40
00:23:45	89,40
00:23:50	89,40
00:23:55	89,40
00:24:00	89,40
00:24:05	89,40
00:24:10	89,40
00:24:15	89,40
00:24:20	89,40
00:24:25	89,40
00:24:30	89,40
00:24:35	89,40
00:24:40	89,40
00:24:45	89,40
00:24:50	89,40
00:24:55	89,40
00:25:00	89,40
00:25:05	89,40
00:25:10	89,40
00:25:15	89,40
00:25:20	89,40
00:25:25	89,40
00:25:30	89,40
00:25:35	89,40
00:25:40	89,40
00:25:45	89,40
00:25:50	89,40
00:25:55	89,40
00:26:00	89,40
00:26:05	89,40
00:26:10	89,40
00:26:15	89,40
00:26:20	89,40
00:26:25	89,40

00:26:30	89,40
00:26:35	89,40
00:26:40	89,40
00:26:45	89,30
00:26:50	89,30
00:26:55	89,30
00:27:00	89,40
00:27:05	89,40
00:27:10	89,40
00:27:15	89,40
00:27:20	89,40
00:27:25	89,40
00:27:30	89,40
00:27:35	89,40
00:27:40	89,40
00:27:45	89,40
00:27:50	89,40
00:27:55	89,40
00:28:00	89,40
00:28:05	89,40
00:28:10	89,40
00:28:15	89,40
00:28:20	89,40
00:28:25	89,40
00:28:30	89,40
00:28:35	89,40
00:28:40	89,40
00:28:45	89,40
00:28:50	89,40
00:28:55	89,40
00:29:00	89,40
00:29:05	89,40
00:29:10	89,40
00:29:15	89,40
00:29:20	89,40
00:29:25	89,60
00:29:30	89,60
00:29:35	89,60
00:29:40	89,60
00:29:45	89,60
00:29:50	89,60
00:29:55	89,60
00:30:00	89,60
00:30:05	89,60
00:30:10	89,60
00:30:15	89,60
00:30:20	89,60
00:30:25	89,60
00:30:30	89,60
00:30:35	89,60
00:30:40	89,60
00:30:45	89,40
00:30:50	89,40
00:30:55	89,40
00:31:00	89,40
00:31:05	89,40
00:31:10	89,40
00:31:15	89,40
00:31:20	89,40
00:31:25	89,40
00:31:30	89,40
00:31:35	89,40
00:31:40	89,40
00:31:45	89,40
00:31:50	89,40
00:31:55	89,40
00:32:00	89,40
00:32:05	89,40
00:32:10	89,40
00:32:15	89,40
00:32:20	89,40
00:32:25	89,60
00:32:30	89,60
00:32:35	89,60
00:32:40	89,60
00:32:45	89,60
00:32:50	89,60
00:32:55	89,60
00:33:00	89,60
00:33:05	89,60
00:33:10	89,60
00:33:15	89,70
00:33:20	89,70
00:33:25	89,70
00:33:30	89,70
00:33:35	89,70
00:33:40	89,70
00:33:45	89,70
00:33:50	89,70
00:33:55	89,70
00:34:00	89,70
00:34:05	89,70
00:34:10	89,70
00:34:15	89,70
00:34:20	89,70
00:34:25	89,70
00:34:30	89,70
00:34:35	89,70

00:34:40	89,70
00:34:45	89,70
00:34:50	89,70
00:34:55	89,70
00:35:00	89,70
00:35:05	89,70
00:35:10	89,70
00:35:15	89,70
00:35:20	89,70
00:35:25	89,70
00:35:30	89,70
00:35:35	89,70
00:35:40	89,70
00:35:45	89,80
00:35:50	89,80
00:35:55	89,80
00:36:00	89,80
00:36:05	89,80
00:36:10	89,80
00:36:15	89,80
00:36:20	89,80
00:36:25	89,70
00:36:30	89,70
00:36:35	89,70
00:36:40	89,80
00:36:45	89,80
00:36:50	89,80
00:36:55	89,80
00:37:00	89,80
00:37:05	89,80
00:37:10	89,80
00:37:15	89,80
00:37:20	89,80
00:37:25	89,80
00:37:30	89,80
00:37:35	89,80
00:37:40	89,80
00:37:45	89,80
00:37:50	89,80
00:37:55	89,80
00:38:00	89,80
00:38:05	89,80
00:38:10	89,80
00:38:15	89,80
00:38:20	89,80
00:38:25	89,80
00:38:30	89,80
00:38:35	89,80
00:38:40	89,80
00:38:45	89,80
00:38:50	89,80
00:38:55	89,80
00:39:00	89,80
00:39:05	89,70
00:39:10	89,70
00:39:15	89,70
00:39:20	89,70
00:39:25	89,70
00:39:30	89,70
00:39:35	89,70
00:39:40	89,70
00:39:45	89,70
00:39:50	89,70
00:39:55	89,70
00:40:00	89,70
00:40:05	89,70
00:40:10	89,70
00:40:15	89,70
00:40:20	89,70
00:40:25	89,70
00:40:30	89,70
00:40:35	89,70
00:40:40	89,70
00:40:45	89,70
00:40:50	89,70
00:40:55	89,70
00:41:00	89,70
00:41:05	89,60
00:41:10	89,60
00:41:15	89,60
00:41:20	89,60
00:41:25	89,60
00:41:30	89,60
00:41:35	89,60
00:41:40	89,60
00:41:45	89,60
00:41:50	89,60
00:41:55	89,60
00:42:00	89,60
00:42:05	89,60
00:42:10	89,60
00:42:15	89,60
00:42:20	89,70
00:42:25	89,70
00:42:30	89,70
00:42:35	89,70
00:42:40	89,70
00:42:45	89,60

00:42:50	89,60
00:42:55	89,60
00:43:00	89,60
00:43:05	89,60
00:43:10	89,60
00:43:15	89,60
00:43:20	89,60
00:43:25	89,60
00:43:30	89,40
00:43:35	89,40
00:43:40	89,40
00:43:45	89,40
00:43:50	89,40
00:43:55	89,40
00:44:00	89,40
00:44:05	89,40
00:44:10	89,40
00:44:15	89,40
00:44:20	89,40
00:44:25	89,40
00:44:30	89,40
00:44:35	89,40
00:44:40	89,40
00:44:45	89,40
00:44:50	89,40
00:44:55	89,40
00:45:00	89,40
00:45:05	89,40
00:45:10	89,40
00:45:15	89,40
00:45:20	89,40
00:45:25	89,40
00:45:30	89,40
00:45:35	89,40
00:45:40	89,40
00:45:45	89,40
00:45:50	89,40
00:45:55	89,40
00:46:00	89,40
00:46:05	89,30
00:46:10	89,30
00:46:15	89,40
00:46:20	89,40
00:46:25	89,40
00:46:30	89,40
00:46:35	89,40
00:46:40	89,40
00:46:45	89,40
00:46:50	89,40
00:46:55	89,40
00:47:00	89,40
00:47:05	89,40
00:47:10	89,40
00:47:15	89,40
00:47:20	89,40
00:47:25	89,40
00:47:30	89,40
00:47:35	89,40
00:47:40	89,40
00:47:45	89,40
00:47:50	89,40
00:47:55	89,40
00:48:00	89,40
00:48:05	89,40
00:48:10	89,40
00:48:15	89,40
00:48:20	89,40
00:48:25	89,40
00:48:30	89,40
00:48:35	89,40
00:48:40	89,40
00:48:45	89,40
00:48:50	89,40
00:48:55	89,40
00:49:00	89,40
00:49:05	89,40
00:49:10	89,40
00:49:15	89,40
00:49:20	89,40
00:49:25	89,40
00:49:30	89,40
00:49:35	89,30
00:49:40	89,30
00:49:45	89,30
00:49:50	89,30
00:49:55	89,40
00:50:00	89,40
00:50:05	89,40
00:50:10	89,40
00:50:15	89,40
00:50:20	89,40
00:50:25	89,40
00:50:30	89,40
00:50:35	89,40
00:50:40	89,40
00:50:45	89,40
00:50:50	89,40
00:50:55	89,40

00:51:00	89,40
00:51:05	89,40
00:51:10	89,40
00:51:15	89,40
00:51:20	89,40
00:51:25	89,40
00:51:30	89,40
00:51:35	89,40
00:51:40	89,40
00:51:45	89,40
00:51:50	89,40
00:51:55	89,40
00:52:00	89,40
00:52:05	89,40
00:52:10	89,40
00:52:15	89,40
00:52:20	89,40
00:52:25	89,40
00:52:30	89,40
00:52:35	89,40
00:52:40	89,40
00:52:45	89,40
00:52:50	89,40
00:52:55	89,40
00:53:00	89,40
00:53:05	89,40
00:53:10	89,40
00:53:15	89,40
00:53:20	89,40
00:53:25	89,40
00:53:30	89,40
00:53:35	89,40
00:53:40	89,40
00:53:45	89,40
00:53:50	89,60
00:53:55	89,60
00:54:00	89,60
00:54:05	89,60
00:54:10	89,60
00:54:15	89,70
00:54:20	89,70
00:54:25	89,70
00:54:30	89,70
00:54:35	89,70
00:54:40	89,70
00:54:45	89,70
00:54:50	89,70
00:54:55	89,70
00:55:00	89,70
00:55:05	89,70
00:55:10	89,70
00:55:15	89,70
00:55:20	89,70
00:55:25	89,70
00:55:30	89,70
00:55:35	89,70
00:55:40	89,70
00:55:45	89,70
00:55:50	89,70
00:55:55	89,70
00:56:00	89,70
00:56:05	89,70
00:56:10	89,70
00:56:15	89,70
00:56:20	89,70
00:56:25	89,70
00:56:30	89,70
00:56:35	89,70
00:56:40	89,70
00:56:45	89,70
00:56:50	89,70
00:56:55	89,70
00:57:00	89,70
00:57:05	89,70
00:57:10	89,70
00:57:15	89,70
00:57:20	89,70
00:57:25	89,70
00:57:30	89,70
00:57:35	89,70
00:57:40	89,70
00:57:45	89,70
00:57:50	89,70
00:57:55	89,70
00:58:00	89,70
00:58:05	89,70
00:58:10	89,70
00:58:15	89,70
00:58:20	89,70
00:58:25	89,70
00:58:30	89,70
00:58:35	89,70
00:58:40	89,70
00:58:45	89,70
00:58:50	89,70
00:58:55	89,70
00:59:00	89,70
00:59:05	89,70

00:59:10	89,70
00:59:15	89,70
00:59:20	89,70
00:59:25	89,70
00:59:30	89,70
00:59:35	89,70
00:59:40	89,60
00:59:45	89,60
00:59:50	89,60
00:59:55	89,60
01:00:00	89,60
01:00:05	89,60
01:00:10	89,60
01:00:15	89,60
01:00:20	89,60
01:00:25	89,60
01:00:30	89,60
01:00:35	89,60
01:00:40	89,60
01:00:45	89,60
01:00:50	89,60
01:00:55	89,60
01:01:00	89,60
01:01:05	89,60
01:01:10	89,60
01:01:15	89,60
01:01:20	89,60
01:01:25	89,60
01:01:30	89,60
01:01:35	89,60
01:01:40	89,60
01:01:45	89,70
01:01:50	89,70
01:01:55	89,70
01:02:00	89,70
01:02:05	89,70
01:02:10	89,70
01:02:15	89,70
01:02:20	89,70
01:02:25	89,70
01:02:30	89,70
01:02:35	89,60
01:02:40	89,60
01:02:45	89,60
01:02:50	89,60
01:02:55	89,60
01:03:00	89,60
01:03:05	89,40
01:03:10	89,40
01:03:15	89,40
01:03:20	89,40
01:03:25	89,40
01:03:30	89,40
01:03:35	89,40
01:03:40	89,40
01:03:45	89,40
01:03:50	89,40
01:03:55	89,40
01:04:00	89,40
01:04:05	89,40
01:04:10	89,30
01:04:15	89,30
01:04:20	89,30
01:04:25	89,30
01:04:30	89,30
01:04:35	89,30
01:04:40	89,30
01:04:45	89,30
01:04:50	89,40
01:04:55	89,40
01:05:00	89,40
01:05:05	89,40
01:05:10	89,40
01:05:15	89,40
01:05:20	89,40
01:05:25	89,40
01:05:30	89,40
01:05:35	89,40
01:05:40	89,40
01:05:45	89,40
01:05:50	89,40
01:05:55	89,30
01:06:00	89,30
01:06:05	89,30
01:06:10	89,30
01:06:15	89,30
01:06:20	89,30
01:06:25	89,30
01:06:30	89,30
01:06:35	89,30
01:06:40	89,30
01:06:45	89,30
01:06:50	89,30
01:06:55	89,30
01:07:00	89,30
01:07:05	89,40
01:07:10	89,40
01:07:15	89,40

01:07:20	89,40
01:07:25	89,40
01:07:30	89,40
01:07:35	89,40
01:07:40	89,40
01:07:45	89,40
01:07:50	89,40
01:07:55	89,40
01:08:00	89,40
01:08:05	89,40
01:08:10	89,40
01:08:15	89,40
01:08:20	89,40
01:08:25	89,40
01:08:30	89,40
01:08:35	89,40
01:08:40	89,40
01:08:45	89,40
01:08:50	89,40
01:08:55	89,40
01:09:00	89,40
01:09:05	89,40
01:09:10	89,40
01:09:15	89,40
01:09:20	89,40
01:09:25	89,40
01:09:30	89,60
01:09:35	89,60
01:09:40	89,60
01:09:45	89,70
01:09:50	89,70
01:09:55	89,70
01:10:00	89,70
01:10:05	89,70
01:10:10	89,70
01:10:15	89,70
01:10:20	89,70
01:10:25	89,70
01:10:30	89,70
01:10:35	89,70
01:10:40	89,70
01:10:45	89,70
01:10:50	89,70
01:10:55	89,70
01:11:00	89,70
01:11:05	89,70
01:11:10	89,70
01:11:15	89,70
01:11:20	89,70
01:11:25	89,80
01:11:30	89,80
01:11:35	89,80
01:11:40	89,90
01:11:45	89,90
01:11:50	89,90
01:11:55	89,90
01:12:00	89,90
01:12:05	89,90
01:12:10	89,90
01:12:15	89,90
01:12:20	89,80
01:12:25	89,80
01:12:30	89,80
01:12:35	89,80
01:12:40	89,80
01:12:45	89,80
01:12:50	89,80
01:12:55	89,80
01:13:00	89,80
01:13:05	89,80
01:13:10	89,70
01:13:15	89,70
01:13:20	89,70
01:13:25	89,70
01:13:30	89,70
01:13:35	89,70
01:13:40	89,70
01:13:45	89,70
01:13:50	89,70
01:13:55	89,80
01:14:00	89,80
01:14:05	89,80
01:14:10	89,90
01:14:15	89,90
01:14:20	89,90
01:14:25	89,90
01:14:30	89,90
01:14:35	89,90
01:14:40	89,80
01:14:45	89,80
01:14:50	89,80
01:14:55	89,70
01:15:00	89,70
01:15:05	89,70
01:15:10	89,70
01:15:15	89,70
01:15:20	89,70
01:15:25	89,70

01:15:30	89,70
01:15:35	89,70
01:15:40	89,70
01:15:45	89,70
01:15:50	89,70
01:15:55	89,70
01:16:00	89,70
01:16:05	89,70
01:16:10	89,70
01:16:15	89,70
01:16:20	89,70
01:16:25	89,70
01:16:30	89,70
01:16:35	89,70
01:16:40	89,70
01:16:45	89,70
01:16:50	89,70
01:16:55	89,70
01:17:00	89,70
01:17:05	89,70
01:17:10	89,70
01:17:15	89,60
01:17:20	89,60
01:17:25	89,60
01:17:30	89,60
01:17:35	89,60
01:17:40	89,60
01:17:45	89,60
01:17:50	89,60
01:17:55	89,60
01:18:00	89,60
01:18:05	89,70
01:18:10	89,60
01:18:15	89,60
01:18:20	89,60
01:18:25	89,70
01:18:30	89,70
01:18:35	89,70
01:18:40	89,70
01:18:45	89,70
01:18:50	89,70
01:18:55	89,70
01:19:00	89,70
01:19:05	89,70
01:19:10	89,70
01:19:15	89,70
01:19:20	89,60
01:19:25	89,60
01:19:30	89,60
01:19:35	89,60
01:19:40	89,60
01:19:45	89,60
01:19:50	89,60
01:19:55	89,60
01:20:00	89,40
01:20:05	89,40
01:20:10	89,40
01:20:15	89,40
01:20:20	89,40
01:20:25	89,40
01:20:30	89,40
01:20:35	89,40
01:20:40	89,40
01:20:45	89,40
01:20:50	89,40
01:20:55	89,40
01:21:00	89,40
01:21:05	89,40
01:21:10	89,40
01:21:15	89,60
01:21:20	89,60
01:21:25	89,60
01:21:30	89,60
01:21:35	89,60
01:21:40	89,60
01:21:45	89,60
01:21:50	89,60
01:21:55	89,40
01:22:00	89,40
01:22:05	89,40
01:22:10	89,40
01:22:15	89,40
01:22:20	89,40
01:22:25	89,40
01:22:30	89,40
01:22:35	89,40
01:22:40	89,40
01:22:45	89,40
01:22:50	89,40
01:22:55	89,40
01:23:00	89,40
01:23:05	89,40
01:23:10	89,40
01:23:15	89,60
01:23:20	89,60
01:23:25	89,70
01:23:30	89,70
01:23:35	89,70

01:23:40	89,70
01:23:45	89,70
01:23:50	89,70
01:23:55	89,70
01:24:00	89,70
01:24:05	89,60
01:24:10	89,60
01:24:15	89,60
01:24:20	89,60
01:24:25	89,60
01:24:30	89,40
01:24:35	89,60
01:24:40	89,60
01:24:45	89,60
01:24:50	89,60
01:24:55	89,60
01:25:00	89,70
01:25:05	89,70
01:25:10	89,70
01:25:15	89,70
01:25:20	89,70
01:25:25	89,70
01:25:30	89,70
01:25:35	89,70
01:25:40	89,70
01:25:45	89,70
01:25:50	89,70
01:25:55	89,70
01:26:00	89,70
01:26:05	89,70
01:26:10	89,70
01:26:15	89,70
01:26:20	89,70
01:26:25	89,70
01:26:30	89,70
01:26:35	89,70
01:26:40	89,80
01:26:45	89,80
01:26:50	89,80
01:26:55	89,80
01:27:00	89,80
01:27:05	89,90
01:27:10	89,90
01:27:15	89,90
01:27:20	89,90
01:27:25	89,80
01:27:30	89,80
01:27:35	89,80
01:27:40	89,80
01:27:45	89,80
01:27:50	89,70
01:27:55	89,70
01:28:00	89,70
01:28:05	89,70
01:28:10	89,70
01:28:15	89,70
01:28:20	89,70
01:28:25	89,70
01:28:30	89,70
01:28:35	89,70
01:28:40	89,70
01:28:45	89,70
01:28:50	89,70
01:28:55	89,70
01:29:00	89,70
01:29:05	89,70
01:29:10	89,70
01:29:15	89,70
01:29:20	89,70
01:29:25	89,70
01:29:30	89,70
01:29:35	89,70
01:29:40	89,70
01:29:45	89,70
01:29:50	89,70
01:29:55	89,70
01:30:00	89,70

TEMPERATURA REFRIGERANTE PROMEDIO NAVE #2

[hh:mm:ss]	[°C]	SEGMENTO	1	2	3	4	5	6	7	8	9	10
21:50:00	82,00											
21:50:05	82,60											
21:50:10	83,20											
21:50:15	83,90											
21:50:20	84,40											
21:50:25	84,90											
21:50:30	85,30											
21:50:35	85,60											
21:50:40	85,60											
21:50:45	85,70											
21:50:50	85,50											
21:50:55	85,50											
21:51:00	84,80											
21:51:05	84,50											
21:51:10	84,50											
21:51:15	84,50											
21:51:20	84,70											
21:51:25	85,00											
21:51:30	85,50											
21:51:35	85,50											
21:51:40	86,30											
21:51:45	86,50											
21:51:50	86,70											
21:51:55	86,70											
21:52:00	86,60											
21:52:05	86,40											
21:52:10	86,40											
21:52:15	86,30											
21:52:20	86,10											
21:52:25	86,10											
21:52:30	86,30											
21:52:35	86,50											
21:52:40	86,80											
21:52:45	87,30											
21:52:50	87,50											
21:52:55	87,50											
21:53:00	87,60											
21:53:05	87,50											
21:53:10	87,40											
21:53:15	87,30											
21:53:20	87,20											
21:53:25	87,20											
21:53:30	87,20											
21:53:35	87,20											
21:53:40	87,30											
21:53:45	87,50											
21:53:50	87,60											
21:53:55	88,00											
21:54:00	88,00											
21:54:05	88,10											
21:54:10	88,10											
21:54:15	88,10											
21:54:20	88,10											
21:54:25	88,00											
21:54:30	88,00											
21:54:35	88,00											
21:54:40	88,00											
21:54:45	88,10											
21:54:50	88,20											
21:54:55	88,30											
21:55:00	88,40											
21:55:05	88,50											
21:55:10	88,60											
21:55:15	88,70											
21:55:20	88,70											
21:55:25	88,80											
21:55:30	88,80											
21:55:35	88,90											
21:55:40	89,00											
21:55:45	89,00											
21:55:50	89,10											
21:55:55	89,20											
21:56:00	89,20											
21:56:05	89,30											
21:56:10	89,30											
21:56:15	89,30											
21:56:20	89,40											
21:56:25	89,40											
21:56:30	89,60											
21:56:35	89,60											
21:56:40	89,70											
21:56:45	89,70											
21:56:50	89,70											
21:56:55	89,80											
21:57:00	89,80											
21:57:05	89,90											
21:57:10	90,00											
21:57:15	90,10											
21:57:20	90,10											
21:57:25	90,20											
21:57:30	90,20											
21:57:35	90,30											
21:57:40	90,30											
21:57:45	90,30											

PROMEDIO
SD

89,138 89,762 89,707 89,721 89,693 89,488 89,683 89,709 89,691 89,717
1,43 0,11 0,11 0,09 0,08 0,71 0,12 0,09 0,10 0,09

21:57:50	90,30
21:57:55	90,30
21:58:00	90,30
21:58:05	90,30
21:58:10	90,30
21:58:15	90,30
21:58:20	90,40
21:58:25	90,40
21:58:30	90,50
21:58:35	90,50
21:58:40	90,60
21:58:45	90,60
21:58:50	90,70
21:58:55	90,70
21:59:00	90,80
21:59:05	90,80
21:59:10	90,70
21:59:15	90,70
21:59:20	90,70
21:59:25	90,70
21:59:30	90,60
21:59:35	90,60
21:59:40	90,60
21:59:45	90,60
21:59:50	90,50
21:59:55	90,50
22:00:00	90,50
22:00:05	90,60
22:00:10	90,60
22:00:15	90,60
22:00:20	90,60
22:00:25	90,60
22:00:30	90,50
22:00:35	90,50
22:00:40	90,50
22:00:45	90,50
22:00:50	90,40
22:00:55	90,40
22:01:00	90,40
22:01:05	90,40
22:01:10	90,30
22:01:15	90,30
22:01:20	90,30
22:01:25	90,20
22:01:30	90,20
22:01:35	90,20
22:01:40	90,20
22:01:45	90,10
22:01:50	90,10
22:01:55	90,10
22:02:00	90,10
22:02:05	90,10
22:02:10	90,10
22:02:15	90,10
22:02:20	90,10
22:02:25	90,10
22:02:30	90,00
22:02:35	89,90
22:02:40	89,90
22:02:45	89,90
22:02:50	89,80
22:02:55	89,80
22:03:00	89,80
22:03:05	89,80
22:03:10	89,70
22:03:15	89,70
22:03:20	89,70
22:03:25	89,70
22:03:30	89,70
22:03:35	89,70
22:03:40	89,70
22:03:45	89,70
22:03:50	89,70
22:03:55	89,70
22:04:00	89,70
22:04:05	89,70
22:04:10	89,70
22:04:15	89,70
22:04:20	89,60
22:04:25	89,60
22:04:30	89,40
22:04:35	89,40
22:04:40	89,40
22:04:45	89,40
22:04:50	89,30
22:04:55	89,30
22:05:00	89,30
22:05:05	89,30
22:05:10	89,30
22:05:15	89,30
22:05:20	89,30
22:05:25	89,20
22:05:30	89,20
22:05:35	89,20
22:05:40	89,10
22:05:45	89,10
22:05:50	89,10
22:05:55	89,10

22:06:00	89,10
22:06:05	89,10
22:06:10	89,10
22:06:15	89,20
22:06:20	89,20
22:06:25	89,20
22:06:30	89,20
22:06:35	89,10
22:06:40	89,10
22:06:45	89,10
22:06:50	89,10
22:06:55	89,10
22:07:00	89,10
22:07:05	89,10
22:07:10	89,10
22:07:15	89,10
22:07:20	89,00
22:07:25	89,00
22:07:30	89,00
22:07:35	89,00
22:07:40	89,00
22:07:45	89,10
22:07:50	89,10
22:07:55	89,10
22:08:00	89,20
22:08:05	89,20
22:08:10	89,20
22:08:15	89,20
22:08:20	89,20
22:08:25	89,20
22:08:30	89,20
22:08:35	89,10
22:08:40	89,10
22:08:45	89,10
22:08:50	89,10
22:08:55	89,10
22:09:00	89,10
22:09:05	89,20
22:09:10	89,20
22:09:15	89,20
22:09:20	89,20
22:09:25	89,20
22:09:30	89,20
22:09:35	89,20
22:09:40	89,20
22:09:45	89,20
22:09:50	89,20
22:09:55	89,20
22:10:00	89,20
22:10:05	89,20
22:10:10	89,20
22:10:15	89,20
22:10:20	89,20
22:10:25	89,30
22:10:30	89,30
22:10:35	89,30
22:10:40	89,30
22:10:45	89,30
22:10:50	89,30
22:10:55	89,30
22:11:00	89,30
22:11:05	89,30
22:11:10	89,30
22:11:15	89,30
22:11:20	89,30
22:11:25	89,30
22:11:30	89,30
22:11:35	89,30
22:11:40	89,30
22:11:45	89,30
22:11:50	89,30
22:11:55	89,30
22:12:00	89,30
22:12:05	89,30
22:12:10	89,30
22:12:15	89,40
22:12:20	89,40
22:12:25	89,40
22:12:30	89,40
22:12:35	89,40
22:12:40	89,60
22:12:45	89,60
22:12:50	89,70
22:12:55	89,70
22:13:00	89,70
22:13:05	89,70
22:13:10	89,70
22:13:15	89,70
22:13:20	89,70
22:13:25	89,70
22:13:30	89,70
22:13:35	89,70
22:13:40	89,70
22:13:45	89,70
22:13:50	89,70
22:13:55	89,70
22:14:00	89,70
22:14:05	89,70

22:14:10	89,70
22:14:15	89,70
22:14:20	89,70
22:14:25	89,70
22:14:30	89,70
22:14:35	89,70
22:14:40	89,70
22:14:45	89,70
22:14:50	89,70
22:14:55	89,70
22:15:00	89,70
22:15:05	89,70
22:15:10	89,70
22:15:15	89,70
22:15:20	89,70
22:15:25	89,70
22:15:30	89,70
22:15:35	89,80
22:15:40	89,80
22:15:45	89,80
22:15:50	89,80
22:15:55	89,90
22:16:00	89,90
22:16:05	89,90
22:16:10	89,90
22:16:15	89,90
22:16:20	89,80
22:16:25	89,80
22:16:30	89,80
22:16:35	89,80
22:16:40	89,80
22:16:45	89,80
22:16:50	89,80
22:16:55	89,80
22:17:00	89,80
22:17:05	89,80
22:17:10	89,80
22:17:15	89,80
22:17:20	89,80
22:17:25	89,80
22:17:30	89,80
22:17:35	89,80
22:17:40	89,80
22:17:45	89,80
22:17:50	89,80
22:17:55	89,90
22:18:00	89,90
22:18:05	89,90
22:18:10	89,90
22:18:15	90,00
22:18:20	90,00
22:18:25	90,00
22:18:30	90,00
22:18:35	90,00
22:18:40	90,00
22:18:45	90,00
22:18:50	90,00
22:18:55	89,90
22:19:00	89,90
22:19:05	89,90
22:19:10	89,90
22:19:15	89,90
22:19:20	89,90
22:19:25	89,90
22:19:30	89,90
22:19:35	89,90
22:19:40	89,90
22:19:45	89,90
22:19:50	89,90
22:19:55	89,90
22:20:00	89,90
22:20:05	89,90
22:20:10	89,90
22:20:15	89,80
22:20:20	89,80
22:20:25	89,80
22:20:30	89,80
22:20:35	89,80
22:20:40	89,80
22:20:45	89,80
22:20:50	89,90
22:20:55	89,90
22:21:00	89,90
22:21:05	89,90
22:21:10	89,90
22:21:15	89,90
22:21:20	90,00
22:21:25	90,00
22:21:30	90,00
22:21:35	90,10
22:21:40	90,10
22:21:45	90,10
22:21:50	90,10
22:21:55	90,10
22:22:00	90,10
22:22:05	90,10
22:22:10	90,10
22:22:15	90,10

22:22:20	90,10
22:22:25	90,10
22:22:30	90,00
22:22:35	90,00
22:22:40	90,00
22:22:45	89,90
22:22:50	89,90
22:22:55	89,90
22:23:00	89,90
22:23:05	89,90
22:23:10	89,90
22:23:15	89,90
22:23:20	89,90
22:23:25	89,90
22:23:30	89,90
22:23:35	89,90
22:23:40	89,90
22:23:45	89,90
22:23:50	89,80
22:23:55	89,80
22:24:00	89,80
22:24:05	89,80
22:24:10	89,80
22:24:15	89,80
22:24:20	89,70
22:24:25	89,70
22:24:30	89,70
22:24:35	89,70
22:24:40	89,70
22:24:45	89,80
22:24:50	89,80
22:24:55	89,80
22:25:00	89,80
22:25:05	89,80
22:25:10	89,80
22:25:15	89,80
22:25:20	89,80
22:25:25	89,80
22:25:30	89,90
22:25:35	89,90
22:25:40	89,90
22:25:45	89,90
22:25:50	89,90
22:25:55	89,90
22:26:00	89,90
22:26:05	89,90
22:26:10	89,90
22:26:15	89,90
22:26:20	89,90
22:26:25	89,90
22:26:30	89,90
22:26:35	89,90
22:26:40	89,90
22:26:45	89,90
22:26:50	89,90
22:26:55	89,90
22:27:00	89,90
22:27:05	89,90
22:27:10	89,90
22:27:15	89,90
22:27:20	89,90
22:27:25	89,90
22:27:30	89,90
22:27:35	89,90
22:27:40	89,90
22:27:45	89,90
22:27:50	89,90
22:27:55	89,90
22:28:00	89,80
22:28:05	89,80
22:28:10	89,80
22:28:15	89,80
22:28:20	89,80
22:28:25	89,80
22:28:30	89,80
22:28:35	89,80
22:28:40	89,80
22:28:45	89,80
22:28:50	89,80
22:28:55	89,80
22:29:00	89,80
22:29:05	89,70
22:29:10	89,70
22:29:15	89,70
22:29:20	89,70
22:29:25	89,70
22:29:30	89,70
22:29:35	89,70
22:29:40	89,70
22:29:45	89,70
22:29:50	89,80
22:29:55	89,80
22:30:00	89,80
22:30:05	89,80
22:30:10	89,80
22:30:15	89,80
22:30:20	89,80
22:30:25	89,80

22:30:30	89,80
22:30:35	89,80
22:30:40	89,80
22:30:45	89,80
22:30:50	89,80
22:30:55	89,80
22:31:00	89,80
22:31:05	89,80
22:31:10	89,80
22:31:15	89,80
22:31:20	89,70
22:31:25	89,70
22:31:30	89,70
22:31:35	89,70
22:31:40	89,70
22:31:45	89,80
22:31:50	89,80
22:31:55	89,70
22:32:00	89,70
22:32:05	89,70
22:32:10	89,80
22:32:15	89,80
22:32:20	89,80
22:32:25	89,80
22:32:30	89,80
22:32:35	89,80
22:32:40	89,80
22:32:45	89,80
22:32:50	89,70
22:32:55	89,70
22:33:00	89,70
22:33:05	89,70
22:33:10	89,70
22:33:15	89,80
22:33:20	89,80
22:33:25	89,80
22:33:30	89,80
22:33:35	89,80
22:33:40	89,80
22:33:45	89,90
22:33:50	89,90
22:33:55	89,90
22:34:00	89,90
22:34:05	89,90
22:34:10	89,80
22:34:15	89,80
22:34:20	89,80
22:34:25	89,80
22:34:30	89,80
22:34:35	89,80
22:34:40	89,80
22:34:45	89,80
22:34:50	89,80
22:34:55	89,70
22:35:00	89,70
22:35:05	89,70
22:35:10	89,70
22:35:15	89,70
22:35:20	89,70
22:35:25	89,70
22:35:30	89,70
22:35:35	89,70
22:35:40	89,70
22:35:45	89,70
22:35:50	89,70
22:35:55	89,70
22:36:00	89,70
22:36:05	89,80
22:36:10	89,80
22:36:15	89,80
22:36:20	89,80
22:36:25	89,80
22:36:30	89,80
22:36:35	89,70
22:36:40	89,70
22:36:45	89,70
22:36:50	89,70
22:36:55	89,70
22:37:00	89,70
22:37:05	89,70
22:37:10	89,70
22:37:15	89,70
22:37:20	89,70
22:37:25	89,70
22:37:30	89,70
22:37:35	89,70
22:37:40	89,70
22:37:45	89,80
22:37:50	89,80
22:37:55	89,80
22:38:00	89,80
22:38:05	89,80
22:38:10	89,80
22:38:15	89,70
22:38:20	89,70
22:38:25	89,70
22:38:30	89,70
22:38:35	89,70

22:38:40	89,70
22:38:45	89,70
22:38:50	89,70
22:38:55	89,70
22:39:00	89,70
22:39:05	89,70
22:39:10	89,70
22:39:15	89,70
22:39:20	89,70
22:39:25	89,70
22:39:30	89,70
22:39:35	89,70
22:39:40	89,70
22:39:45	89,70
22:39:50	89,70
22:39:55	89,70
22:40:00	89,70
22:40:05	89,70
22:40:10	89,70
22:40:15	89,70
22:40:20	89,70
22:40:25	89,70
22:40:30	89,70
22:40:35	89,70
22:40:40	89,70
22:40:45	89,70
22:40:50	89,70
22:40:55	89,70
22:41:00	89,70
22:41:05	89,70
22:41:10	89,70
22:41:15	89,70
22:41:20	89,70
22:41:25	89,70
22:41:30	89,70
22:41:35	89,70
22:41:40	89,70
22:41:45	89,70
22:41:50	89,80
22:41:55	89,80
22:42:00	89,80
22:42:05	89,80
22:42:10	89,70
22:42:15	89,70
22:42:20	89,70
22:42:25	89,70
22:42:30	89,70
22:42:35	89,70
22:42:40	89,70
22:42:45	89,60
22:42:50	89,60
22:42:55	89,60
22:43:00	89,60
22:43:05	89,60
22:43:10	89,60
22:43:15	89,60
22:43:20	89,60
22:43:25	89,60
22:43:30	89,60
22:43:35	89,60
22:43:40	89,70
22:43:45	89,70
22:43:50	89,70
22:43:55	89,70
22:44:00	89,70
22:44:05	89,70
22:44:10	89,70
22:44:15	89,70
22:44:20	89,70
22:44:25	89,70
22:44:30	89,60
22:44:35	89,60
22:44:40	89,60
22:44:45	89,60
22:44:50	89,60
22:44:55	89,60
22:45:00	89,60
22:45:05	89,60
22:45:10	89,60
22:45:15	89,60
22:45:20	89,60
22:45:25	89,60
22:45:30	89,60
22:45:35	89,60
22:45:40	89,70
22:45:45	89,70
22:45:50	89,70
22:45:55	89,70
22:46:00	89,60
22:46:05	89,60
22:46:10	89,60
22:46:15	89,60
22:46:20	89,60
22:46:25	89,70
22:46:30	89,70
22:46:35	89,70
22:46:40	89,70
22:46:45	89,70

22:46:50	89,70
22:46:55	89,70
22:47:00	89,70
22:47:05	89,60
22:47:10	89,60
22:47:15	89,60
22:47:20	89,60
22:47:25	89,60
22:47:30	89,60
22:47:35	89,60
22:47:40	89,60
22:47:45	89,60
22:47:50	89,60
22:47:55	89,60
22:48:00	89,60
22:48:05	89,60
22:48:10	89,60
22:48:15	89,60
22:48:20	89,60
22:48:25	89,60
22:48:30	89,60
22:48:35	89,60
22:48:40	89,60
22:48:45	89,70
22:48:50	89,70
22:48:55	89,70
22:49:00	89,70
22:49:05	89,70
22:49:10	89,70
22:49:15	89,70
22:49:20	89,70
22:49:25	89,70
22:49:30	89,70
22:49:35	89,70
22:49:40	89,70
22:49:45	89,70
22:49:50	89,80
22:49:55	89,80
22:50:00	89,80
22:50:05	89,90
22:50:10	89,90
22:50:15	89,90
22:50:20	89,90
22:50:25	89,90
22:50:30	89,90
22:50:35	89,90
22:50:40	89,90
22:50:45	89,90
22:50:50	89,80
22:50:55	89,80
22:51:00	89,80
22:51:05	89,70
22:51:10	89,70
22:51:15	89,70
22:51:20	89,70
22:51:25	89,70
22:51:30	89,70
22:51:35	89,70
22:51:40	89,70
22:51:45	89,70
22:51:50	89,70
22:51:55	89,70
22:52:00	89,70
22:52:05	89,70
22:52:10	89,70
22:52:15	89,70
22:52:20	89,70
22:52:25	89,70
22:52:30	89,70
22:52:35	89,70
22:52:40	89,70
22:52:45	89,70
22:52:50	89,70
22:52:55	89,70
22:53:00	89,70
22:53:05	89,70
22:53:10	89,70
22:53:15	89,70
22:53:20	89,70
22:53:25	89,70
22:53:30	89,70
22:53:35	89,70
22:53:40	89,70
22:53:45	89,70
22:53:50	89,70
22:53:55	89,70
22:54:00	89,70
22:54:05	89,70
22:54:10	89,70
22:54:15	89,70
22:54:20	89,70
22:54:25	89,60
22:54:30	89,60
22:54:35	89,60
22:54:40	89,60
22:54:45	89,60
22:54:50	89,60
22:54:55	89,70

22:55:00	89,70
22:55:05	89,70
22:55:10	89,70
22:55:15	89,70
22:55:20	89,70
22:55:25	89,70
22:55:30	89,70
22:55:35	89,70
22:55:40	89,70
22:55:45	89,70
22:55:50	89,80
22:55:55	89,80
22:56:00	89,80
22:56:05	89,80
22:56:10	89,80
22:56:15	89,80
22:56:20	89,80
22:56:25	89,80
22:56:30	89,70
22:56:35	89,70
22:56:40	89,70
22:56:45	89,70
22:56:50	89,70
22:56:55	89,70
22:57:00	89,70
22:57:05	89,70
22:57:10	89,70
22:57:15	89,70
22:57:20	89,70
22:57:25	89,70
22:57:30	89,70
22:57:35	89,70
22:57:40	89,70
22:57:45	89,70
22:57:50	89,70
22:57:55	89,70
22:58:00	89,70
22:58:05	89,70
22:58:10	89,70
22:58:15	89,70
22:58:20	89,70
22:58:25	89,70
22:58:30	89,70
22:58:35	89,70
22:58:40	89,70
22:58:45	89,70
22:58:50	89,70
22:58:55	89,70
22:59:00	89,70
22:59:05	89,70
22:59:10	89,70
22:59:15	89,70
22:59:20	89,70
22:59:25	89,70
22:59:30	89,70
22:59:35	89,70
22:59:40	89,70
22:59:45	89,70
22:59:50	89,70
22:59:55	89,70
23:00:00	89,70
23:00:05	89,70
23:00:10	89,70
23:00:15	89,70
23:00:20	89,70
23:00:25	89,70
23:00:30	89,70
23:00:35	89,70
23:00:40	89,70
23:00:45	89,70
23:00:50	89,70
23:00:55	89,70
23:01:00	89,70
23:01:05	89,70
23:01:10	89,70
23:01:15	89,70
23:01:20	89,70
23:01:25	89,70
23:01:30	89,70
23:01:35	89,70
23:01:40	89,70
23:01:45	89,70
23:01:50	89,70
23:01:55	89,70
23:02:00	89,70
23:02:05	89,70
23:02:10	89,70
23:02:15	89,70
23:02:20	89,70
23:02:25	89,70
23:02:30	89,70
23:02:35	89,70
23:02:40	89,70
23:02:45	89,80
23:02:50	89,80
23:02:55	89,80
23:03:00	89,80
23:03:05	89,90

23:03:10	89,90
23:03:15	89,90
23:03:20	89,90
23:03:25	89,90
23:03:30	89,80
23:03:35	89,80
23:03:40	89,80
23:03:45	89,80
23:03:50	89,70
23:03:55	89,70
23:04:00	89,70
23:04:05	89,70
23:04:10	89,70
23:04:15	89,70
23:04:20	89,70
23:04:25	89,70
23:04:30	89,70
23:04:35	89,70
23:04:40	89,70
23:04:45	89,70
23:04:50	89,70
23:04:55	89,70
23:05:00	89,70
23:05:05	89,80
23:05:10	89,80
23:05:15	89,80
23:05:20	89,80
23:05:25	89,80
23:05:30	89,80
23:05:35	89,80
23:05:40	89,80
23:05:45	89,90
23:05:50	89,80
23:05:55	89,80
23:06:00	89,80
23:06:05	89,80
23:06:10	89,80
23:06:15	89,80
23:06:20	89,80
23:06:25	89,80
23:06:30	89,80
23:06:35	89,80
23:06:40	89,80
23:06:45	89,80
23:06:50	89,80
23:06:55	89,80
23:07:00	89,80
23:07:05	89,80
23:07:10	89,80
23:07:15	89,80
23:07:20	89,80
23:07:25	89,90
23:07:30	89,90
23:07:35	89,90
23:07:40	89,90
23:07:45	89,90
23:07:50	89,90
23:07:55	89,80
23:08:00	89,80
23:08:05	89,80
23:08:10	89,80
23:08:15	89,80
23:08:20	89,80
23:08:25	89,80
23:08:30	89,80
23:08:35	89,80
23:08:40	89,80
23:08:45	89,70
23:08:50	89,80
23:08:55	89,80
23:09:00	89,80
23:09:05	89,80
23:09:10	89,80
23:09:15	89,80
23:09:20	89,80
23:09:25	89,80
23:09:30	89,90
23:09:35	89,90
23:09:40	89,90
23:09:45	89,90
23:09:50	89,90
23:09:55	89,90
23:10:00	89,90
23:10:05	89,90
23:10:10	89,80
23:10:15	89,80
23:10:20	89,80
23:10:25	89,80
23:10:30	89,80
23:10:35	89,70
23:10:40	89,70
23:10:45	89,70
23:10:50	89,70
23:10:55	89,70
23:11:00	89,70
23:11:05	89,70
23:11:10	89,70
23:11:15	89,70

23:11:20	89,70
23:11:25	89,70
23:11:30	89,70
23:11:35	89,70
23:11:40	89,70
23:11:45	89,70
23:11:50	89,70
23:11:55	89,70
23:12:00	89,70
23:12:05	89,70
23:12:10	89,70
23:12:15	89,70
23:12:20	89,70
23:12:25	89,70
23:12:30	89,70
23:12:35	89,70
23:12:40	89,70
23:12:45	89,70
23:12:50	89,70
23:12:55	89,70
23:13:00	89,70
23:13:05	89,70
23:13:10	89,70
23:13:15	89,70
23:13:20	89,70
23:13:25	89,70
23:13:30	89,70
23:13:35	89,70
23:13:40	89,70
23:13:45	89,70
23:13:50	89,70
23:13:55	89,70
23:14:00	89,70
23:14:05	89,70
23:14:10	89,70
23:14:15	89,70
23:14:20	89,60
23:14:25	89,60
23:14:30	89,60
23:14:35	89,60
23:14:40	89,60
23:14:45	89,60
23:14:50	89,60
23:14:55	89,60
23:15:00	89,60
23:15:05	89,60
23:15:10	89,60
23:15:15	89,60
23:15:20	89,60
23:15:25	89,70
23:15:30	89,70
23:15:35	89,70
23:15:40	89,70
23:15:45	89,70
23:15:50	89,70
23:15:55	89,70
23:16:00	89,70
23:16:05	89,70
23:16:10	89,60
23:16:15	89,60
23:16:20	89,40
23:16:25	89,40
23:16:30	89,40
23:16:35	89,40
23:16:40	89,30
23:16:45	89,30
23:16:50	89,40
23:16:55	89,40
23:17:00	89,40
23:17:05	89,40
23:17:10	89,40
23:17:15	89,40
23:17:20	89,60
23:17:25	89,60
23:17:30	89,60
23:17:35	89,60
23:17:40	89,40
23:17:45	89,60
23:17:50	89,40
23:17:55	89,40
23:18:00	89,40
23:18:05	89,40
23:18:10	89,40
23:18:15	89,40
23:18:20	89,40
23:18:25	89,40
23:18:30	89,40
23:18:35	89,40
23:18:40	89,60
23:18:45	89,60
23:18:50	89,60
23:18:55	89,60
23:19:00	89,60
23:19:05	89,70
23:19:10	89,70
23:19:15	89,70
23:19:20	89,70
23:19:25	89,70

23:19:30	89,70
23:19:35	89,70
23:19:40	89,70
23:19:45	89,70
23:19:50	89,70
23:19:55	89,70
23:20:00	89,70
23:20:05	89,70
23:20:10	89,70
23:20:15	89,70
23:20:20	89,70
23:20:25	89,70
23:20:30	89,70
23:20:35	89,70
23:20:40	89,70
23:20:45	89,70
23:20:50	89,70
23:20:55	89,70
23:21:00	89,70
23:21:05	89,70
23:21:10	89,80
23:21:15	89,80
23:21:20	89,80
23:21:25	89,80
23:21:30	89,70
23:21:35	89,70
23:21:40	89,70
23:21:45	89,70
23:21:50	89,70
23:21:55	89,70
23:22:00	89,70
23:22:05	89,70
23:22:10	89,70
23:22:15	89,70
23:22:20	89,70
23:22:25	89,70
23:22:30	89,80
23:22:35	89,80
23:22:40	89,80
23:22:45	89,80
23:22:50	89,80
23:22:55	89,90
23:23:00	89,90
23:23:05	89,90
23:23:10	89,90
23:23:15	89,90
23:23:20	89,90
23:23:25	89,90
23:23:30	89,90
23:23:35	89,90
23:23:40	89,90
23:23:45	89,90
23:23:50	89,90
23:23:55	89,80
23:24:00	89,80
23:24:05	89,80
23:24:10	89,80
23:24:15	89,80
23:24:20	89,80
23:24:25	89,90
23:24:30	89,90
23:24:35	89,90
23:24:40	89,90
23:24:45	89,90
23:24:50	89,90
23:24:55	89,90
23:25:00	89,90
23:25:05	89,90
23:25:10	89,90
23:25:15	89,90
23:25:20	89,90
23:25:25	89,90
23:25:30	89,80
23:25:35	89,80
23:25:40	89,80
23:25:45	89,80
23:25:50	89,80
23:25:55	89,70
23:26:00	89,70
23:26:05	89,70
23:26:10	89,70
23:26:15	89,70
23:26:20	89,70
23:26:25	89,70
23:26:30	89,70
23:26:35	89,70
23:26:40	89,70
23:26:45	89,70
23:26:50	89,60
23:26:55	89,60
23:27:00	89,60
23:27:05	89,60
23:27:10	89,60
23:27:15	89,60
23:27:20	89,60
23:27:25	89,70
23:27:30	89,70
23:27:35	89,70

23:27:40	89,70
23:27:45	89,70
23:27:50	89,70
23:27:55	89,60
23:28:00	89,60
23:28:05	89,60
23:28:10	89,60
23:28:15	89,60
23:28:20	89,60
23:28:25	89,60
23:28:30	89,60
23:28:35	89,60
23:28:40	89,60
23:28:45	89,60
23:28:50	89,60
23:28:55	89,60
23:29:00	89,60
23:29:05	89,60
23:29:10	89,60
23:29:15	89,60
23:29:20	89,60
23:29:25	89,60
23:29:30	89,60
23:29:35	89,60
23:29:40	89,60
23:29:45	89,60
23:29:50	89,60
23:29:55	89,60
23:30:00	89,60
23:30:05	89,60
23:30:10	89,60
23:30:15	89,60
23:30:20	89,60
23:30:25	89,60
23:30:30	89,60
23:30:35	89,60
23:30:40	89,60
23:30:45	89,60
23:30:50	89,70
23:30:55	89,70
23:31:00	89,70
23:31:05	89,70
23:31:10	89,70
23:31:15	89,70
23:31:20	89,70
23:31:25	89,70
23:31:30	89,70
23:31:35	89,70
23:31:40	89,70
23:31:45	89,70
23:31:50	89,70
23:31:55	89,70
23:32:00	89,60
23:32:05	89,60
23:32:10	89,60
23:32:15	89,60
23:32:20	89,40
23:32:25	89,40
23:32:30	89,40
23:32:35	89,40
23:32:40	89,40
23:32:45	89,40
23:32:50	89,60
23:32:55	89,60
23:33:00	89,60
23:33:05	89,60
23:33:10	89,60
23:33:15	89,70
23:33:20	89,70
23:33:25	89,70
23:33:30	89,70
23:33:35	89,70
23:33:40	89,70
23:33:45	89,70
23:33:50	89,70
23:33:55	89,70
23:34:00	89,70
23:34:05	89,70
23:34:10	89,70
23:34:15	89,70
23:34:20	89,70
23:34:25	89,70
23:34:30	89,70
23:34:35	89,70
23:34:40	89,70
23:34:45	89,70
23:34:50	89,70
23:34:55	89,70
23:35:00	89,70
23:35:05	89,70
23:35:10	89,70
23:35:15	89,70
23:35:20	89,70
23:35:25	89,70
23:35:30	89,70
23:35:35	89,70
23:35:40	89,70
23:35:45	89,70

23:35:50	89,70
23:35:55	89,70
23:36:00	89,70
23:36:05	89,70
23:36:10	89,70
23:36:15	89,70
23:36:20	89,70
23:36:25	89,70
23:36:30	89,70
23:36:35	89,70
23:36:40	89,70
23:36:45	89,70
23:36:50	89,70
23:36:55	89,70
23:37:00	89,70
23:37:05	89,70
23:37:10	89,70
23:37:15	89,70
23:37:20	89,70
23:37:25	89,70
23:37:30	89,70
23:37:35	89,70
23:37:40	89,70
23:37:45	89,70
23:37:50	89,80
23:37:55	89,80
23:38:00	89,80
23:38:05	89,70
23:38:10	89,70
23:38:15	89,70
23:38:20	89,70
23:38:25	89,70
23:38:30	89,70
23:38:35	89,70
23:38:40	89,70
23:38:45	89,70
23:38:50	89,70
23:38:55	89,70
23:39:00	89,70
23:39:05	89,70
23:39:10	89,70
23:39:15	89,70
23:39:20	89,70
23:39:25	89,70
23:39:30	89,70
23:39:35	89,70
23:39:40	89,70
23:39:45	89,70
23:39:50	89,70
23:39:55	89,80
23:40:00	89,80
23:40:05	89,80
23:40:10	89,70
23:40:15	89,70
23:40:20	89,70
23:40:25	89,70
23:40:30	89,70
23:40:35	89,70
23:40:40	89,70
23:40:45	89,70
23:40:50	89,70
23:40:55	89,70
23:41:00	89,80
23:41:05	89,80
23:41:10	89,80
23:41:15	89,80
23:41:20	89,80
23:41:25	89,80
23:41:30	89,80
23:41:35	89,80
23:41:40	89,80
23:41:45	89,80
23:41:50	89,80
23:41:55	89,80
23:42:00	89,80
23:42:05	89,80
23:42:10	89,80
23:42:15	89,80
23:42:20	89,80
23:42:25	89,80
23:42:30	89,80
23:42:35	89,80
23:42:40	89,80
23:42:45	89,80
23:42:50	89,80
23:42:55	89,80
23:43:00	89,80
23:43:05	89,80
23:43:10	89,80
23:43:15	89,80
23:43:20	89,80
23:43:25	89,80
23:43:30	89,80
23:43:35	89,80
23:43:40	89,90
23:43:45	89,90
23:43:50	89,90
23:43:55	89,90

23:44:00	89,80
23:44:05	89,80
23:44:10	89,90
23:44:15	89,90
23:44:20	89,90
23:44:25	89,90
23:44:30	89,90
23:44:35	89,90
23:44:40	89,90
23:44:45	89,80
23:44:50	89,80
23:44:55	89,80
23:45:00	89,80
23:45:05	89,70
23:45:10	89,70
23:45:15	89,70
23:45:20	89,70
23:45:25	89,70
23:45:30	89,70
23:45:35	89,70
23:45:40	89,70
23:45:45	89,70
23:45:50	89,70
23:45:55	89,70
23:46:00	89,70
23:46:05	89,70
23:46:10	89,80
23:46:15	89,80
23:46:20	89,80
23:46:25	89,80
23:46:30	89,80
23:46:35	89,80
23:46:40	89,80
23:46:45	89,80
23:46:50	89,70
23:46:55	89,70
23:47:00	89,70
23:47:05	89,70
23:47:10	89,70
23:47:15	89,70
23:47:20	89,70
23:47:25	89,70
23:47:30	89,70
23:47:35	89,70
23:47:40	89,70
23:47:45	89,70
23:47:50	89,70
23:47:55	89,70
23:48:00	89,70
23:48:05	89,70
23:48:10	89,70
23:48:15	89,70
23:48:20	89,70
23:48:25	89,70
23:48:30	89,70
23:48:35	89,70
23:48:40	89,70
23:48:45	89,70
23:48:50	89,70
23:48:55	89,70
23:49:00	89,70
23:49:05	89,70
23:49:10	89,70
23:49:15	89,70
23:49:20	89,70
23:49:25	89,70
23:49:30	89,70
23:49:35	89,70
23:49:40	89,70
23:49:45	89,70
23:49:50	89,70
23:49:55	89,70
23:50:00	89,70
23:50:05	89,70
23:50:10	89,70
23:50:15	89,70
23:50:20	89,70
23:50:25	89,70
23:50:30	89,70
23:50:35	89,70
23:50:40	89,70
23:50:45	89,70
23:50:50	89,70
23:50:55	89,70
23:51:00	89,70
23:51:05	89,70
23:51:10	89,70
23:51:15	89,70
23:51:20	89,70
23:51:25	89,70
23:51:30	89,70
23:51:35	89,70
23:51:40	89,70
23:51:45	89,70
23:51:50	89,70
23:51:55	89,70
23:52:00	89,70
23:52:05	89,70

23:52:10	89,70
23:52:15	89,70
23:52:20	89,70
23:52:25	89,70
23:52:30	89,70
23:52:35	89,70
23:52:40	89,70
23:52:45	89,70
23:52:50	89,70
23:52:55	89,70
23:53:00	89,70
23:53:05	89,70
23:53:10	89,70
23:53:15	89,70
23:53:20	89,70
23:53:25	89,70
23:53:30	89,70
23:53:35	89,70
23:53:40	89,70
23:53:45	89,70
23:53:50	89,70
23:53:55	89,70
23:54:00	89,70
23:54:05	89,70
23:54:10	89,70
23:54:15	89,70
23:54:20	89,70
23:54:25	89,70
23:54:30	89,70
23:54:35	89,60
23:54:40	89,60
23:54:45	89,60
23:54:50	89,60
23:54:55	89,60
23:55:00	89,60
23:55:05	89,40
23:55:10	89,40
23:55:15	89,40
23:55:20	89,40
23:55:25	89,40
23:55:30	89,40
23:55:35	89,60
23:55:40	89,60
23:55:45	89,60
23:55:50	89,60
23:55:55	89,60
23:56:00	89,60
23:56:05	89,60
23:56:10	89,70
23:56:15	89,70
23:56:20	89,70
23:56:25	89,70
23:56:30	89,70
23:56:35	89,60
23:56:40	89,60
23:56:45	89,60
23:56:50	89,60
23:56:55	89,60
23:57:00	89,60
23:57:05	89,60
23:57:10	89,60
23:57:15	89,60
23:57:20	89,60
23:57:25	89,60
23:57:30	89,60
23:57:35	89,60
23:57:40	89,60
23:57:45	89,60
23:57:50	89,60
23:57:55	89,60
23:58:00	89,60
23:58:05	89,60
23:58:10	89,60
23:58:15	89,60
23:58:20	89,60
23:58:25	89,60
23:58:30	89,60
23:58:35	89,60
23:58:40	89,60
23:58:45	89,60
23:58:50	89,60
23:58:55	89,60
23:59:00	89,60
23:59:05	89,60
23:59:10	89,60
23:59:15	89,60
23:59:20	89,70
23:59:25	89,70
23:59:30	89,70
23:59:35	89,70
23:59:40	89,70
23:59:45	89,60
23:59:50	89,60
23:59:55	89,60
00:00:00	89,60
00:00:05	89,60
00:00:10	89,60
00:00:15	89,60

00:00:20	89,60
00:00:25	89,60
00:00:30	89,60
00:00:35	89,60
00:00:40	89,70
00:00:45	89,70
00:00:50	89,70
00:00:55	89,70
00:01:00	89,70
00:01:05	89,70
00:01:10	89,70
00:01:15	89,70
00:01:20	89,70
00:01:25	89,70
00:01:30	89,70
00:01:35	89,70
00:01:40	89,70
00:01:45	89,70
00:01:50	89,70
00:01:55	89,70
00:02:00	89,70
00:02:05	89,70
00:02:10	89,70
00:02:15	89,70
00:02:20	89,70
00:02:25	89,70
00:02:30	89,70
00:02:35	89,70
00:02:40	89,70
00:02:45	89,70
00:02:50	89,70
00:02:55	89,70
00:03:00	89,70
00:03:05	89,70
00:03:10	89,70
00:03:15	89,70
00:03:20	89,70
00:03:25	89,70
00:03:30	89,70
00:03:35	89,70
00:03:40	89,70
00:03:45	89,70
00:03:50	89,70
00:03:55	89,70
00:04:00	89,70
00:04:05	89,70
00:04:10	89,70
00:04:15	89,70
00:04:20	89,70
00:04:25	89,70
00:04:30	89,70
00:04:35	89,70
00:04:40	89,70
00:04:45	89,70
00:04:50	89,70
00:04:55	89,70
00:05:00	89,70
00:05:05	89,70
00:05:10	89,70
00:05:15	89,70
00:05:20	89,70
00:05:25	89,70
00:05:30	89,70
00:05:35	89,70
00:05:40	89,70
00:05:45	89,70
00:05:50	89,70
00:05:55	89,70
00:06:00	89,70
00:06:05	89,70
00:06:10	89,70
00:06:15	89,70
00:06:20	89,70
00:06:25	89,70
00:06:30	89,80
00:06:35	89,80
00:06:40	89,80
00:06:45	89,80
00:06:50	89,90
00:06:55	89,90
00:07:00	89,90
00:07:05	89,90
00:07:10	89,90
00:07:15	89,90
00:07:20	89,90
00:07:25	89,90
00:07:30	89,90
00:07:35	89,90
00:07:40	89,90
00:07:45	89,90
00:07:50	89,80
00:07:55	89,80
00:08:00	89,80
00:08:05	89,80
00:08:10	89,80
00:08:15	89,80
00:08:20	89,80
00:08:25	89,80

00:08:30	89,80
00:08:35	89,80
00:08:40	89,80
00:08:45	89,80
00:08:50	89,80
00:08:55	89,80
00:09:00	89,80
00:09:05	89,80
00:09:10	89,80
00:09:15	89,80
00:09:20	89,80
00:09:25	89,80
00:09:30	89,80
00:09:35	89,80
00:09:40	89,80
00:09:45	89,80
00:09:50	89,80
00:09:55	89,80
00:10:00	89,80
00:10:05	89,70
00:10:10	89,70
00:10:15	89,70
00:10:20	89,70
00:10:25	89,70
00:10:30	89,70
00:10:35	89,70
00:10:40	89,70
00:10:45	89,70
00:10:50	89,70
00:10:55	89,70
00:11:00	89,70
00:11:05	89,70
00:11:10	89,70
00:11:15	89,70
00:11:20	89,70
00:11:25	89,70
00:11:30	89,70
00:11:35	89,70
00:11:40	89,70
00:11:45	89,70
00:11:50	89,70
00:11:55	89,70
00:12:00	89,70
00:12:05	89,70
00:12:10	89,70
00:12:15	89,70
00:12:20	89,60
00:12:25	89,60
00:12:30	89,60
00:12:35	89,60
00:12:40	89,60
00:12:45	89,60
00:12:50	89,60
00:12:55	89,60
00:13:00	89,60
00:13:05	89,60
00:13:10	89,60
00:13:15	89,60
00:13:20	89,70
00:13:25	89,70
00:13:30	89,70
00:13:35	89,70
00:13:40	89,70
00:13:45	89,70
00:13:50	89,70
00:13:55	89,70
00:14:00	89,70
00:14:05	89,70
00:14:10	89,70
00:14:15	89,70
00:14:20	89,70
00:14:25	89,70
00:14:30	89,70
00:14:35	89,70
00:14:40	89,70
00:14:45	89,70
00:14:50	89,70
00:14:55	89,70
00:15:00	89,70
00:15:05	89,70
00:15:10	89,70
00:15:15	89,70
00:15:20	89,70
00:15:25	89,70
00:15:30	89,70
00:15:35	89,70
00:15:40	89,70
00:15:45	89,70
00:15:50	89,70
00:15:55	89,70
00:16:00	89,70
00:16:05	89,70
00:16:10	89,70
00:16:15	89,70
00:16:20	89,70
00:16:25	89,70
00:16:30	89,70
00:16:35	89,70

00:16:40	89,70
00:16:45	89,70
00:16:50	89,70
00:16:55	89,70
00:17:00	89,70
00:17:05	89,70
00:17:10	89,60
00:17:15	89,60
00:17:20	89,60
00:17:25	89,60
00:17:30	89,70
00:17:35	89,70
00:17:40	89,70
00:17:45	89,70
00:17:50	89,70
00:17:55	89,70
00:18:00	89,70
00:18:05	89,70
00:18:10	89,70
00:18:15	89,70
00:18:20	89,70
00:18:25	89,70
00:18:30	89,70
00:18:35	89,70
00:18:40	89,70
00:18:45	89,70
00:18:50	89,70
00:18:55	89,70
00:19:00	89,70
00:19:05	89,80
00:19:10	89,80
00:19:15	89,80
00:19:20	89,80
00:19:25	89,80
00:19:30	89,80
00:19:35	89,80
00:19:40	89,80
00:19:45	89,80
00:19:50	89,80
00:19:55	89,80
00:20:00	89,70
00:20:05	89,80
00:20:10	89,80
00:20:15	89,80
00:20:20	89,80
00:20:25	89,80
00:20:30	89,80
00:20:35	89,80
00:20:40	89,80
00:20:45	89,70
00:20:50	89,70
00:20:55	89,70
00:21:00	89,70
00:21:05	89,70
00:21:10	89,70
00:21:15	89,70
00:21:20	89,70
00:21:25	89,70
00:21:30	89,70
00:21:35	89,70
00:21:40	89,70
00:21:45	89,60
00:21:50	89,60
00:21:55	89,60
00:22:00	89,60
00:22:05	89,60
00:22:10	89,60
00:22:15	89,70
00:22:20	89,70
00:22:25	89,70
00:22:30	89,70
00:22:35	89,70
00:22:40	89,70
00:22:45	89,70
00:22:50	89,70
00:22:55	89,70
00:23:00	89,70
00:23:05	89,70
00:23:10	89,70
00:23:15	89,70
00:23:20	89,70
00:23:25	89,70
00:23:30	89,70
00:23:35	89,70
00:23:40	89,70
00:23:45	89,80
00:23:50	89,80
00:23:55	89,80
00:24:00	89,80
00:24:05	89,80
00:24:10	89,80
00:24:15	89,80
00:24:20	89,80
00:24:25	89,80
00:24:30	89,80
00:24:35	89,80
00:24:40	89,80
00:24:45	89,80

00:24:50	89,80
00:24:55	89,80
00:25:00	89,80
00:25:05	89,80
00:25:10	89,80
00:25:15	89,90
00:25:20	89,90
00:25:25	89,90
00:25:30	89,90
00:25:35	89,90
00:25:40	89,90
00:25:45	89,90
00:25:50	89,90
00:25:55	89,90
00:26:00	89,90
00:26:05	89,90
00:26:10	89,90
00:26:15	89,90
00:26:20	89,80
00:26:25	89,80
00:26:30	89,80
00:26:35	89,80
00:26:40	89,80
00:26:45	89,80
00:26:50	89,80
00:26:55	89,80
00:27:00	89,80
00:27:05	89,80
00:27:10	89,80
00:27:15	89,80
00:27:20	89,80
00:27:25	89,80
00:27:30	89,80
00:27:35	89,80
00:27:40	89,80
00:27:45	89,80
00:27:50	89,80
00:27:55	89,80
00:28:00	89,80
00:28:05	89,80
00:28:10	89,80
00:28:15	89,80
00:28:20	89,80
00:28:25	89,80
00:28:30	89,70
00:28:35	89,10
00:28:40	88,20
00:28:45	87,30
00:28:50	86,30
00:28:55	86,10
00:29:00	86,10
00:29:05	86,30
00:29:10	86,50
00:29:15	86,80
00:29:20	87,30
00:29:25	87,50
00:29:30	87,50
00:29:35	87,60
00:29:40	87,50
00:29:45	87,40
00:29:50	87,30
00:29:55	87,20
00:30:00	87,20
00:30:05	87,20
00:30:10	87,20
00:30:15	87,30
00:30:20	87,50
00:30:25	87,60
00:30:30	88,00
00:30:35	88,00
00:30:40	88,10
00:30:45	88,10
00:30:50	88,10
00:30:55	88,10
00:31:00	88,00
00:31:05	88,00
00:31:10	88,00
00:31:15	88,00
00:31:20	88,10
00:31:25	88,20
00:31:30	88,30
00:31:35	88,40
00:31:40	88,50
00:31:45	88,60
00:31:50	88,70
00:31:55	88,70
00:32:00	88,80
00:32:05	88,80
00:32:10	88,90
00:32:15	89,00
00:32:20	89,00
00:32:25	89,10
00:32:30	89,20
00:32:35	89,20
00:32:40	89,30
00:32:45	89,30
00:32:50	89,30
00:32:55	89,70

00:33:00	89,70
00:33:05	89,70
00:33:10	89,70
00:33:15	89,70
00:33:20	89,70
00:33:25	89,70
00:33:30	89,70
00:33:35	89,70
00:33:40	89,70
00:33:45	89,70
00:33:50	89,70
00:33:55	89,70
00:34:00	89,70
00:34:05	89,70
00:34:10	89,70
00:34:15	89,70
00:34:20	89,70
00:34:25	89,70
00:34:30	89,70
00:34:35	89,70
00:34:40	89,70
00:34:45	89,70
00:34:50	89,70
00:34:55	89,70
00:35:00	89,70
00:35:05	89,70
00:35:10	89,70
00:35:15	89,70
00:35:20	89,70
00:35:25	89,70
00:35:30	89,70
00:35:35	89,70
00:35:40	89,70
00:35:45	89,70
00:35:50	89,60
00:35:55	89,60
00:36:00	89,60
00:36:05	89,60
00:36:10	89,60
00:36:15	89,60
00:36:20	89,70
00:36:25	89,70
00:36:30	89,70
00:36:35	89,70
00:36:40	89,70
00:36:45	89,70
00:36:50	89,70
00:36:55	89,70
00:37:00	89,70
00:37:05	89,70
00:37:10	89,70
00:37:15	89,80
00:37:20	89,80
00:37:25	89,80
00:37:30	89,80
00:37:35	89,80
00:37:40	89,80
00:37:45	89,80
00:37:50	89,80
00:37:55	89,70
00:38:00	89,70
00:38:05	89,70
00:38:10	89,70
00:38:15	89,70
00:38:20	89,70
00:38:25	89,70
00:38:30	89,70
00:38:35	89,70
00:38:40	89,70
00:38:45	89,70
00:38:50	89,70
00:38:55	89,70
00:39:00	89,70
00:39:05	89,70
00:39:10	89,70
00:39:15	89,70
00:39:20	89,70
00:39:25	89,70
00:39:30	89,70
00:39:35	89,70
00:39:40	89,70
00:39:45	89,70
00:39:50	89,70
00:39:55	89,70
00:40:00	89,70
00:40:05	89,70
00:40:10	89,70
00:40:15	89,70
00:40:20	89,70
00:40:25	89,70
00:40:30	89,70
00:40:35	89,70
00:40:40	89,70
00:40:45	89,70
00:40:50	89,70
00:40:55	89,70
00:41:00	89,70
00:41:05	89,70

00:41:10	89,70
00:41:15	89,70
00:41:20	89,70
00:41:25	89,70
00:41:30	89,70
00:41:35	89,70
00:41:40	89,70
00:41:45	89,70
00:41:50	89,70
00:41:55	89,70
00:42:00	89,70
00:42:05	89,70
00:42:10	89,70
00:42:15	89,70
00:42:20	89,70
00:42:25	89,70
00:42:30	89,70
00:42:35	89,70
00:42:40	89,70
00:42:45	89,70
00:42:50	89,70
00:42:55	89,70
00:43:00	89,70
00:43:05	89,70
00:43:10	89,70
00:43:15	89,70
00:43:20	89,70
00:43:25	89,70
00:43:30	89,70
00:43:35	89,70
00:43:40	89,70
00:43:45	89,70
00:43:50	89,70
00:43:55	89,70
00:44:00	89,70
00:44:05	89,70
00:44:10	89,80
00:44:15	89,80
00:44:20	89,80
00:44:25	89,80
00:44:30	89,90
00:44:35	89,90
00:44:40	89,90
00:44:45	89,90
00:44:50	89,90
00:44:55	89,80
00:45:00	89,80
00:45:05	89,80
00:45:10	89,80
00:45:15	89,70
00:45:20	89,70
00:45:25	89,70
00:45:30	89,70
00:45:35	89,70
00:45:40	89,70
00:45:45	89,70
00:45:50	89,70
00:45:55	89,70
00:46:00	89,70
00:46:05	89,70
00:46:10	89,70
00:46:15	89,70
00:46:20	89,70
00:46:25	89,70
00:46:30	89,80
00:46:35	89,80
00:46:40	89,80
00:46:45	89,80
00:46:50	89,80
00:46:55	89,80
00:47:00	89,80
00:47:05	89,80
00:47:10	89,90
00:47:15	89,80
00:47:20	89,80
00:47:25	89,80
00:47:30	89,80
00:47:35	89,80
00:47:40	89,80
00:47:45	89,80
00:47:50	89,80
00:47:55	89,80
00:48:00	89,80
00:48:05	89,80
00:48:10	89,80
00:48:15	89,80
00:48:20	89,80
00:48:25	89,80
00:48:30	89,80
00:48:35	89,80
00:48:40	89,80
00:48:45	89,80
00:48:50	89,90
00:48:55	89,90
00:49:00	89,90
00:49:05	89,90
00:49:10	89,90
00:49:15	89,90

00:49:20	89,80
00:49:25	89,80
00:49:30	89,80
00:49:35	89,80
00:49:40	89,80
00:49:45	89,80
00:49:50	89,80
00:49:55	89,80
00:50:00	89,80
00:50:05	89,80
00:50:10	89,70
00:50:15	89,80
00:50:20	89,80
00:50:25	89,80
00:50:30	89,80
00:50:35	89,80
00:50:40	89,80
00:50:45	89,80
00:50:50	89,80
00:50:55	89,90
00:51:00	89,90
00:51:05	89,90
00:51:10	89,90
00:51:15	89,90
00:51:20	89,90
00:51:25	89,90
00:51:30	89,90
00:51:35	89,80
00:51:40	89,80
00:51:45	89,80
00:51:50	89,80
00:51:55	89,80
00:52:00	89,70
00:52:05	89,70
00:52:10	89,70
00:52:15	89,70
00:52:20	89,70
00:52:25	89,70
00:52:30	89,70
00:52:35	89,70
00:52:40	89,70
00:52:45	89,70
00:52:50	89,70
00:52:55	89,70
00:53:00	89,70
00:53:05	89,70
00:53:10	89,70
00:53:15	89,70
00:53:20	89,70
00:53:25	89,70
00:53:30	89,70
00:53:35	89,70
00:53:40	89,70
00:53:45	89,70
00:53:50	89,70
00:53:55	89,70
00:54:00	89,70
00:54:05	89,70
00:54:10	89,70
00:54:15	89,70
00:54:20	89,70
00:54:25	89,70
00:54:30	89,70
00:54:35	89,70
00:54:40	89,70
00:54:45	89,70
00:54:50	89,70
00:54:55	89,70
00:55:00	89,70
00:55:05	89,70
00:55:10	89,70
00:55:15	89,70
00:55:20	89,70
00:55:25	89,70
00:55:30	89,70
00:55:35	89,70
00:55:40	89,70
00:55:45	89,60
00:55:50	89,60
00:55:55	89,60
00:56:00	89,60
00:56:05	89,60
00:56:10	89,60
00:56:15	89,60
00:56:20	89,60
00:56:25	89,60
00:56:30	89,60
00:56:35	89,60
00:56:40	89,60
00:56:45	89,60
00:56:50	89,70
00:56:55	89,70
00:57:00	89,70
00:57:05	89,70
00:57:10	89,70
00:57:15	89,70
00:57:20	89,70
00:57:25	89,70

00:57:30	89,70
00:57:35	89,60
00:57:40	89,60
00:57:45	89,40
00:57:50	89,40
00:57:55	89,40
00:58:00	89,40
00:58:05	89,30
00:58:10	89,30
00:58:15	89,40
00:58:20	89,40
00:58:25	89,40
00:58:30	89,40
00:58:35	89,40
00:58:40	89,40
00:58:45	89,60
00:58:50	89,60
00:58:55	89,60
00:59:00	89,60
00:59:05	89,40
00:59:10	89,60
00:59:15	89,40
00:59:20	89,40
00:59:25	89,40
00:59:30	89,40
00:59:35	89,40
00:59:40	89,40
00:59:45	89,40
00:59:50	89,40
00:59:55	89,40
01:00:00	89,40
01:00:05	89,60
01:00:10	89,60
01:00:15	89,60
01:00:20	89,60
01:00:25	89,60
01:00:30	89,70
01:00:35	89,70
01:00:40	89,70
01:00:45	89,70
01:00:50	89,70
01:00:55	89,70
01:01:00	89,70
01:01:05	89,70
01:01:10	89,70
01:01:15	89,70
01:01:20	89,70
01:01:25	89,70
01:01:30	89,70
01:01:35	89,70
01:01:40	89,70
01:01:45	89,70
01:01:50	89,70
01:01:55	89,70
01:02:00	89,70
01:02:05	89,70
01:02:10	89,70
01:02:15	89,70
01:02:20	89,70
01:02:25	89,70
01:02:30	89,70
01:02:35	89,80
01:02:40	89,80
01:02:45	89,80
01:02:50	89,80
01:02:55	89,70
01:03:00	89,70
01:03:05	89,70
01:03:10	89,70
01:03:15	89,70
01:03:20	89,70
01:03:25	89,70
01:03:30	89,70
01:03:35	89,70
01:03:40	89,70
01:03:45	89,70
01:03:50	89,70
01:03:55	89,80
01:04:00	89,80
01:04:05	89,80
01:04:10	89,80
01:04:15	89,80
01:04:20	89,90
01:04:25	89,90
01:04:30	89,90
01:04:35	89,90
01:04:40	89,90
01:04:45	89,90
01:04:50	89,90
01:04:55	89,90
01:05:00	89,90
01:05:05	89,90
01:05:10	89,90
01:05:15	89,90
01:05:20	89,80
01:05:25	89,80
01:05:30	89,80
01:05:35	89,80

01:05:40	89,80
01:05:45	89,80
01:05:50	89,90
01:05:55	89,90
01:06:00	89,90
01:06:05	89,90
01:06:10	89,90
01:06:15	89,90
01:06:20	89,90
01:06:25	89,90
01:06:30	89,90
01:06:35	89,90
01:06:40	89,90
01:06:45	89,90
01:06:50	89,90
01:06:55	89,80
01:07:00	89,80
01:07:05	89,80
01:07:10	89,80
01:07:15	89,80
01:07:20	89,70
01:07:25	89,70
01:07:30	89,70
01:07:35	89,70
01:07:40	89,70
01:07:45	89,70
01:07:50	89,70
01:07:55	89,70
01:08:00	89,70
01:08:05	89,70
01:08:10	89,70
01:08:15	89,60
01:08:20	89,60
01:08:25	89,60
01:08:30	89,60
01:08:35	89,60
01:08:40	89,60
01:08:45	89,60
01:08:50	89,70
01:08:55	89,70
01:09:00	89,70
01:09:05	89,70
01:09:10	89,70
01:09:15	89,70
01:09:20	89,60
01:09:25	89,60
01:09:30	89,60
01:09:35	89,60
01:09:40	89,60
01:09:45	89,60
01:09:50	89,60
01:09:55	89,60
01:10:00	89,60
01:10:05	89,60
01:10:10	89,60
01:10:15	89,60
01:10:20	89,60
01:10:25	89,60
01:10:30	89,60
01:10:35	89,60
01:10:40	89,60
01:10:45	89,60
01:10:50	89,60
01:10:55	89,60
01:11:00	89,60
01:11:05	89,60
01:11:10	89,60
01:11:15	89,60
01:11:20	89,60
01:11:25	89,60
01:11:30	89,60
01:11:35	89,60
01:11:40	89,60
01:11:45	89,60
01:11:50	89,60
01:11:55	89,60
01:12:00	89,60
01:12:05	89,60
01:12:10	89,60
01:12:15	89,70
01:12:20	89,70
01:12:25	89,70
01:12:30	89,70
01:12:35	89,70
01:12:40	89,70
01:12:45	89,70
01:12:50	89,70
01:12:55	89,70
01:13:00	89,70
01:13:05	89,70
01:13:10	89,70
01:13:15	89,70
01:13:20	89,70
01:13:25	89,60
01:13:30	89,60
01:13:35	89,60
01:13:40	89,60
01:13:45	89,40

01:13:50	89,40
01:13:55	89,40
01:14:00	89,40
01:14:05	89,40
01:14:10	89,40
01:14:15	89,60
01:14:20	89,60
01:14:25	89,60
01:14:30	89,60
01:14:35	89,60
01:14:40	89,70
01:14:45	89,70
01:14:50	89,70
01:14:55	89,70
01:15:00	89,70
01:15:05	89,70
01:15:10	89,70
01:15:15	89,70
01:15:20	89,70
01:15:25	89,70
01:15:30	89,70
01:15:35	89,70
01:15:40	89,70
01:15:45	89,70
01:15:50	89,70
01:15:55	89,70
01:16:00	89,70
01:16:05	89,70
01:16:10	89,70
01:16:15	89,70
01:16:20	89,70
01:16:25	89,70
01:16:30	89,70
01:16:35	89,70
01:16:40	89,70
01:16:45	89,70
01:16:50	89,70
01:16:55	89,70
01:17:00	89,70
01:17:05	89,70
01:17:10	89,70
01:17:15	89,70
01:17:20	89,70
01:17:25	89,70
01:17:30	89,70
01:17:35	89,70
01:17:40	89,70
01:17:45	89,70
01:17:50	89,70
01:17:55	89,70
01:18:00	89,70
01:18:05	89,70
01:18:10	89,70
01:18:15	89,70
01:18:20	89,70
01:18:25	89,70
01:18:30	89,70
01:18:35	89,70
01:18:40	89,70
01:18:45	89,70
01:18:50	89,70
01:18:55	89,70
01:19:00	89,70
01:19:05	89,70
01:19:10	89,70
01:19:15	89,80
01:19:20	89,80
01:19:25	89,80
01:19:30	89,70
01:19:35	89,70
01:19:40	89,70
01:19:45	89,70
01:19:50	89,70
01:19:55	89,70
01:20:00	89,70
01:20:05	89,70
01:20:10	89,70
01:20:15	89,70
01:20:20	89,70
01:20:25	89,70
01:20:30	89,70
01:20:35	89,70
01:20:40	89,70
01:20:45	89,70
01:20:50	89,70
01:20:55	89,70
01:21:00	89,70
01:21:05	89,70
01:21:10	89,70
01:21:15	89,70
01:21:20	89,80
01:21:25	89,80
01:21:30	89,80
01:21:35	89,70
01:21:40	89,70
01:21:45	89,70
01:21:50	89,70
01:21:55	89,70

01:22:00	89,70
01:22:05	89,70
01:22:10	89,70
01:22:15	89,70
01:22:20	89,70
01:22:25	89,80
01:22:30	89,80
01:22:35	89,80
01:22:40	89,80
01:22:45	89,80
01:22:50	89,80
01:22:55	89,80
01:23:00	89,80
01:23:05	89,80
01:23:10	89,80
01:23:15	89,80
01:23:20	89,80
01:23:25	89,80
01:23:30	89,80
01:23:35	89,80
01:23:40	89,80
01:23:45	89,80
01:23:50	89,80
01:23:55	89,80
01:24:00	89,80
01:24:05	89,80
01:24:10	89,80
01:24:15	89,80
01:24:20	89,80
01:24:25	89,80
01:24:30	89,80
01:24:35	89,80
01:24:40	89,80
01:24:45	89,80
01:24:50	89,80
01:24:55	89,80
01:25:00	89,80
01:25:05	89,90
01:25:10	89,90
01:25:15	89,90
01:25:20	89,90
01:25:25	89,80
01:25:30	89,80
01:25:35	89,90
01:25:40	89,90
01:25:45	89,90
01:25:50	89,90
01:25:55	89,90
01:26:00	89,90
01:26:05	89,90
01:26:10	89,80
01:26:15	89,80
01:26:20	89,80
01:26:25	89,80
01:26:30	89,70
01:26:35	89,70
01:26:40	89,70
01:26:45	89,70
01:26:50	89,70
01:26:55	89,70
01:27:00	89,70
01:27:05	89,70
01:27:10	89,70
01:27:15	89,70
01:27:20	89,70
01:27:25	89,70
01:27:30	89,70
01:27:35	89,80
01:27:40	89,80
01:27:45	89,80
01:27:50	89,80
01:27:55	89,80
01:28:00	89,80
01:28:05	89,80
01:28:10	89,80
01:28:15	89,70
01:28:20	89,70
01:28:25	89,70
01:28:30	89,70
01:28:35	89,70
01:28:40	89,70
01:28:45	89,70
01:28:50	89,70
01:28:55	89,70
01:29:00	89,70
01:29:05	89,70
01:29:10	89,70
01:29:15	89,70
01:29:20	89,70
01:29:25	89,70
01:29:30	89,70
01:29:35	89,70
01:29:40	89,70
01:29:45	89,70
01:29:50	89,70
01:29:55	89,70
01:30:00	89,70
01:30:05	89,70

01:30:10	89,70
01:30:15	89,70
01:30:20	89,70
01:30:25	89,70
01:30:30	89,70
01:30:35	89,70
01:30:40	89,70
01:30:45	89,70
01:30:50	89,70
01:30:55	89,70
01:31:00	89,70
01:31:05	89,70
01:31:10	89,70
01:31:15	89,70
01:31:20	89,70
01:31:25	89,70
01:31:30	89,70
01:31:35	89,70
01:31:40	89,70
01:31:45	89,70
01:31:50	89,70
01:31:55	89,70
01:32:00	89,70
01:32:05	89,70
01:32:10	89,70
01:32:15	89,70
01:32:20	89,70
01:32:25	89,70
01:32:30	89,70
01:32:35	89,70
01:32:40	89,70
01:32:45	89,70
01:32:50	89,70
01:32:55	89,70
01:33:00	89,70
01:33:05	89,70
01:33:10	89,70
01:33:15	89,70
01:33:20	89,70
01:33:25	89,70
01:33:30	89,70
01:33:35	89,70
01:33:40	89,70
01:33:45	89,70
01:33:50	89,70
01:33:55	89,70
01:34:00	89,70
01:34:05	89,70
01:34:10	89,70
01:34:15	89,70
01:34:20	89,70
01:34:25	89,70
01:34:30	89,70
01:34:35	89,70
01:34:40	89,70
01:34:45	89,70
01:34:50	89,70
01:34:55	89,70
01:35:00	89,70
01:35:05	89,70
01:35:10	89,70
01:35:15	89,70
01:35:20	89,70
01:35:25	89,70
01:35:30	89,70
01:35:35	89,70
01:35:40	89,70
01:35:45	89,70
01:35:50	89,70
01:35:55	89,70
01:36:00	89,60
01:36:05	89,60
01:36:10	89,60
01:36:15	89,60
01:36:20	89,60
01:36:25	89,60
01:36:30	89,40
01:36:35	89,40
01:36:40	89,40
01:36:45	89,40
01:36:50	89,40
01:36:55	89,40
01:37:00	89,60
01:37:05	89,60
01:37:10	89,60
01:37:15	89,60
01:37:20	89,60
01:37:25	89,60
01:37:30	89,60
01:37:35	89,70
01:37:40	89,70
01:37:45	89,70
01:37:50	89,70
01:37:55	89,70
01:38:00	89,60
01:38:05	89,60
01:38:10	89,60
01:38:15	89,60

01:38:20	89,60
01:38:25	89,60
01:38:30	89,60
01:38:35	89,60
01:38:40	89,60
01:38:45	89,60
01:38:50	89,60
01:38:55	89,60
01:39:00	89,60
01:39:05	89,60
01:39:10	89,60
01:39:15	89,60
01:39:20	89,60
01:39:25	89,60
01:39:30	89,60
01:39:35	89,60
01:39:40	89,60
01:39:45	89,60
01:39:50	89,60
01:39:55	89,60
01:40:00	89,60
01:40:05	89,60
01:40:10	89,60
01:40:15	89,60
01:40:20	89,60
01:40:25	89,60
01:40:30	89,60
01:40:35	89,60
01:40:40	89,60
01:40:45	89,70
01:40:50	89,70
01:40:55	89,70
01:41:00	89,70
01:41:05	89,70
01:41:10	89,60
01:41:15	89,60
01:41:20	89,60
01:41:25	89,60
01:41:30	89,60
01:41:35	89,60
01:41:40	89,60
01:41:45	89,60
01:41:50	89,60
01:41:55	89,60
01:42:00	89,60
01:42:05	89,70
01:42:10	89,70
01:42:15	89,70
01:42:20	89,70
01:42:25	89,70
01:42:30	89,70
01:42:35	89,70
01:42:40	89,70
01:42:45	89,70
01:42:50	89,70
01:42:55	89,70
01:43:00	89,70
01:43:05	89,70
01:43:10	89,70
01:43:15	89,70
01:43:20	89,70
01:43:25	89,70
01:43:30	89,70
01:43:35	89,70
01:43:40	89,70
01:43:45	89,70
01:43:50	89,70
01:43:55	89,70
01:44:00	89,70
01:44:05	89,70
01:44:10	89,70
01:44:15	89,70
01:44:20	89,70
01:44:25	89,70
01:44:30	89,70
01:44:35	89,70
01:44:40	89,70
01:44:45	89,70
01:44:50	89,70
01:44:55	89,70
01:45:00	89,70
01:45:05	89,70
01:45:10	89,70
01:45:15	89,70
01:45:20	89,70
01:45:25	89,70
01:45:30	89,70
01:45:35	89,70
01:45:40	89,70
01:45:45	89,70
01:45:50	89,70
01:45:55	89,70
01:46:00	89,70
01:46:05	89,70
01:46:10	89,70
01:46:15	89,70
01:46:20	89,70
01:46:25	89,70

01:46:30	89,70
01:46:35	89,70
01:46:40	89,70
01:46:45	89,70
01:46:50	89,70
01:46:55	89,70
01:47:00	89,70
01:47:05	89,70
01:47:10	89,70
01:47:15	89,70
01:47:20	89,70
01:47:25	89,70
01:47:30	89,70
01:47:35	89,70
01:47:40	89,70
01:47:45	89,70
01:47:50	89,70
01:47:55	89,80
01:48:00	89,80
01:48:05	89,80
01:48:10	89,80
01:48:15	89,90
01:48:20	89,90
01:48:25	89,90
01:48:30	89,90
01:48:35	89,90
01:48:40	89,90
01:48:45	89,90
01:48:50	89,90
01:48:55	89,90
01:49:00	89,90
01:49:05	89,90
01:49:10	89,90
01:49:15	89,80
01:49:20	89,80
01:49:25	89,80
01:49:30	89,80
01:49:35	89,80
01:49:40	89,80
01:49:45	89,80
01:49:50	89,80
01:49:55	89,80
01:50:00	89,80
01:50:05	89,80
01:50:10	89,80
01:50:15	89,80
01:50:20	89,80
01:50:25	89,80
01:50:30	89,80
01:50:35	89,80
01:50:40	89,80
01:50:45	89,80
01:50:50	89,80
01:50:55	89,80
01:51:00	89,80
01:51:05	89,80
01:51:10	89,80
01:51:15	89,80
01:51:20	89,80
01:51:25	89,80
01:51:30	89,70
01:51:35	89,70
01:51:40	89,70
01:51:45	89,70
01:51:50	89,70
01:51:55	89,70
01:52:00	89,70
01:52:05	89,70
01:52:10	89,70
01:52:15	89,70
01:52:20	89,70
01:52:25	89,70
01:52:30	89,70
01:52:35	89,70
01:52:40	89,70
01:52:45	89,70
01:52:50	89,70
01:52:55	89,70
01:53:00	89,70
01:53:05	89,70
01:53:10	89,70
01:53:15	89,70
01:53:20	89,70
01:53:25	89,70
01:53:30	89,70
01:53:35	89,70
01:53:40	89,70
01:53:45	89,60
01:53:50	89,60
01:53:55	89,60
01:54:00	89,60
01:54:05	89,60
01:54:10	89,60
01:54:15	89,60
01:54:20	89,60
01:54:25	89,60
01:54:30	89,60
01:54:35	89,60

01:54:40	89,60
01:54:45	89,70
01:54:50	89,70
01:54:55	89,70
01:55:00	89,70
01:55:05	89,70
01:55:10	89,70
01:55:15	89,70
01:55:20	89,70
01:55:25	89,70
01:55:30	89,70
01:55:35	89,70
01:55:40	89,70
01:55:45	89,70
01:55:50	89,70
01:55:55	89,70
01:56:00	89,70
01:56:05	89,70
01:56:10	89,70
01:56:15	89,70
01:56:20	89,70
01:56:25	89,70
01:56:30	89,70
01:56:35	89,70
01:56:40	89,70
01:56:45	89,70
01:56:50	89,70
01:56:55	89,70
01:57:00	89,70
01:57:05	89,70
01:57:10	89,70
01:57:15	89,70
01:57:20	89,70
01:57:25	89,70
01:57:30	89,70
01:57:35	89,70
01:57:40	89,70
01:57:45	89,70
01:57:50	89,70
01:57:55	89,70
01:58:00	89,70
01:58:05	89,70
01:58:10	89,70
01:58:15	89,70
01:58:20	89,70
01:58:25	89,70
01:58:30	89,70
01:58:35	89,60
01:58:40	89,60
01:58:45	89,60
01:58:50	89,60
01:58:55	89,70
01:59:00	89,70
01:59:05	89,70
01:59:10	89,70
01:59:15	89,70
01:59:20	89,70
01:59:25	89,70
01:59:30	89,70
01:59:35	89,70
01:59:40	89,70
01:59:45	89,70
01:59:50	89,70
01:59:55	89,70
02:00:00	89,70
02:00:05	89,70
02:00:10	89,70
02:00:15	89,70
02:00:20	89,70
02:00:25	89,70
02:00:30	89,80
02:00:35	89,80
02:00:40	89,80
02:00:45	89,80
02:00:50	89,80
02:00:55	89,80
02:01:00	89,80
02:01:05	89,80
02:01:10	89,80
02:01:15	89,80
02:01:20	89,80
02:01:25	89,70
02:01:30	89,80
02:01:35	89,80
02:01:40	89,80
02:01:45	89,80
02:01:50	89,80
02:01:55	89,80
02:02:00	89,80
02:02:05	89,80
02:02:10	89,70
02:02:15	89,70
02:02:20	89,70
02:02:25	89,70
02:02:30	89,70
02:02:35	89,70
02:02:40	89,70
02:02:45	89,70

02:02:50	89,70
02:02:55	89,70
02:03:00	89,70
02:03:05	89,70
02:03:10	89,60
02:03:15	89,60
02:03:20	89,60
02:03:25	89,60
02:03:30	89,60
02:03:35	89,60
02:03:40	89,70
02:03:45	89,70
02:03:50	89,70
02:03:55	89,70
02:04:00	89,70
02:04:05	89,70
02:04:10	89,70
02:04:15	89,70
02:04:20	89,70
02:04:25	89,70
02:04:30	89,70
02:04:35	89,70
02:04:40	89,70
02:04:45	89,70
02:04:50	89,70
02:04:55	89,70
02:05:00	89,70
02:05:05	89,70
02:05:10	89,80
02:05:15	89,80
02:05:20	89,80
02:05:25	89,80
02:05:30	89,80
02:05:35	89,80
02:05:40	89,70
02:05:45	89,80
02:05:50	89,80
02:05:55	89,80
02:06:00	89,80
02:06:05	89,80
02:06:10	89,80
02:06:15	89,80
02:06:20	89,80
02:06:25	89,90
02:06:30	89,90
02:06:35	89,90
02:06:40	89,90
02:06:45	89,90
02:06:50	89,90
02:06:55	89,90
02:07:00	89,90
02:07:05	89,80
02:07:10	89,80
02:07:15	89,80
02:07:20	89,80
02:07:25	89,80
02:07:30	89,70
02:07:35	89,70
02:07:40	89,70
02:07:45	89,70
02:07:50	89,70
02:07:55	89,70
02:08:00	89,70
02:08:05	89,70
02:08:10	89,70
02:08:15	89,70
02:08:20	89,70
02:08:25	89,70
02:08:30	89,70
02:08:35	89,70
02:08:40	89,70
02:08:45	89,70
02:08:50	89,70
02:08:55	89,70
02:09:00	89,70
02:09:05	89,70
02:09:10	89,70
02:09:15	89,70
02:09:20	89,70
02:09:25	89,70
02:09:30	89,70
02:09:35	89,70
02:09:40	89,70
02:09:45	89,70
02:09:50	89,70
02:09:55	89,70
02:10:00	89,70
02:10:05	89,70
02:10:10	89,70
02:10:15	89,70
02:10:20	89,70
02:10:25	89,70
02:10:30	89,70
02:10:35	89,70
02:10:40	89,70
02:10:45	89,70
02:10:50	89,70
02:10:55	89,70

02:11:00	89,70
02:11:05	89,70
02:11:10	89,70
02:11:15	89,60
02:11:20	89,60
02:11:25	89,60
02:11:30	89,60
02:11:35	89,60
02:11:40	89,60
02:11:45	89,60
02:11:50	89,60
02:11:55	89,60
02:12:00	89,60
02:12:05	89,60
02:12:10	89,60
02:12:15	89,60
02:12:20	89,70
02:12:25	89,70
02:12:30	89,70
02:12:35	89,70
02:12:40	89,70
02:12:45	89,70
02:12:50	89,70
02:12:55	89,70
02:13:00	89,70
02:13:05	89,60
02:13:10	89,60
02:13:15	89,40
02:13:20	89,40
02:13:25	89,40
02:13:30	89,40
02:13:35	89,30
02:13:40	89,30
02:13:45	89,40
02:13:50	89,40
02:13:55	89,40
02:14:00	89,40
02:14:05	89,40
02:14:10	89,40
02:14:15	89,60
02:14:20	89,60
02:14:25	89,60
02:14:30	89,60
02:14:35	89,40
02:14:40	89,60
02:14:45	89,40
02:14:50	89,40
02:14:55	89,40
02:15:00	89,40
02:15:05	89,40
02:15:10	89,40
02:15:15	89,40
02:15:20	89,40
02:15:25	89,40
02:15:30	89,40
02:15:35	89,60
02:15:40	89,60
02:15:45	89,60
02:15:50	89,60
02:15:55	89,60
02:16:00	89,70
02:16:05	89,70
02:16:10	89,70
02:16:15	89,70
02:16:20	89,70
02:16:25	89,70
02:16:30	89,70
02:16:35	89,70
02:16:40	89,70
02:16:45	89,70
02:16:50	89,70
02:16:55	89,70
02:17:00	89,70
02:17:05	89,70
02:17:10	89,70
02:17:15	89,70
02:17:20	89,70
02:17:25	89,70
02:17:30	89,70
02:17:35	89,70
02:17:40	89,70
02:17:45	89,70
02:17:50	89,70
02:17:55	89,70
02:18:00	89,70
02:18:05	89,80
02:18:10	89,80
02:18:15	89,80
02:18:20	89,80
02:18:25	89,70
02:18:30	89,70
02:18:35	89,70
02:18:40	89,70
02:18:45	89,70
02:18:50	89,70
02:18:55	89,70
02:19:00	89,70
02:19:05	89,70

02:19:10	89,70
02:19:15	89,70
02:19:20	89,70
02:19:25	89,80
02:19:30	89,80
02:19:35	89,80
02:19:40	89,80
02:19:45	89,80
02:19:50	89,90
02:19:55	89,90
02:20:00	89,90
02:20:05	89,90
02:20:10	89,90
02:20:15	89,90
02:20:20	89,90
02:20:25	89,90
02:20:30	89,90
02:20:35	89,90
02:20:40	89,90
02:20:45	89,90
02:20:50	89,80
02:20:55	89,80
02:21:00	89,80
02:21:05	89,80
02:21:10	89,80
02:21:15	89,80
02:21:20	89,90
02:21:25	89,90
02:21:30	89,90
02:21:35	89,90
02:21:40	89,90
02:21:45	89,90
02:21:50	89,90
02:21:55	89,90
02:22:00	89,90
02:22:05	89,90
02:22:10	89,90
02:22:15	89,90
02:22:20	89,90
02:22:25	89,80
02:22:30	89,80
02:22:35	89,80
02:22:40	89,80
02:22:45	89,80
02:22:50	89,70
02:22:55	89,70
02:23:00	89,70
02:23:05	89,70
02:23:10	89,70
02:23:15	89,70
02:23:20	89,70
02:23:25	89,70
02:23:30	89,70
02:23:35	89,70
02:23:40	89,70
02:23:45	89,60
02:23:50	89,60
02:23:55	89,60
02:24:00	89,60
02:24:05	89,60
02:24:10	89,60
02:24:15	89,60
02:24:20	89,70
02:24:25	89,70
02:24:30	89,70
02:24:35	89,70
02:24:40	89,70
02:24:45	89,70
02:24:50	89,60
02:24:55	89,60
02:25:00	89,60
02:25:05	89,60
02:25:10	89,60
02:25:15	89,60
02:25:20	89,60
02:25:25	89,60
02:25:30	89,60
02:25:35	89,60
02:25:40	89,60
02:25:45	89,60
02:25:50	89,60
02:25:55	89,60
02:26:00	89,60
02:26:05	89,60
02:26:10	89,60
02:26:15	89,60
02:26:20	89,60
02:26:25	89,60
02:26:30	89,60
02:26:35	89,60
02:26:40	89,60
02:26:45	89,60
02:26:50	89,60
02:26:55	89,60
02:27:00	89,60
02:27:05	89,60
02:27:10	89,60
02:27:15	89,60

02:27:20	89,60
02:27:25	89,60
02:27:30	89,60
02:27:35	89,60
02:27:40	89,60
02:27:45	89,70
02:27:50	89,70
02:27:55	89,70
02:28:00	89,70
02:28:05	89,70
02:28:10	89,70
02:28:15	89,70
02:28:20	89,70
02:28:25	89,70
02:28:30	89,70
02:28:35	89,70
02:28:40	89,70
02:28:45	89,70
02:28:50	89,70
02:28:55	89,60
02:29:00	89,60
02:29:05	89,60
02:29:10	89,60
02:29:15	89,40
02:29:20	89,40
02:29:25	89,40
02:29:30	89,40
02:29:35	89,40
02:29:40	89,40
02:29:45	89,60
02:29:50	89,60
02:29:55	89,60
02:30:00	89,60
02:30:05	89,60
02:30:10	89,70
02:30:15	89,70
02:30:20	89,70
02:30:25	89,70
02:30:30	89,70
02:30:35	89,70
02:30:40	89,70
02:30:45	89,70
02:30:50	89,70
02:30:55	89,70
02:31:00	89,70
02:31:05	89,70
02:31:10	89,70
02:31:15	89,70
02:31:20	89,70
02:31:25	89,70
02:31:30	89,70
02:31:35	89,70
02:31:40	89,70
02:31:45	89,70
02:31:50	89,70
02:31:55	89,70
02:32:00	89,70
02:32:05	89,70
02:32:10	89,70
02:32:15	89,70
02:32:20	89,70
02:32:25	89,70
02:32:30	89,70
02:32:35	89,70
02:32:40	89,70
02:32:45	89,70
02:32:50	89,70
02:32:55	89,70
02:33:00	89,70
02:33:05	89,70
02:33:10	89,70
02:33:15	89,70
02:33:20	89,70
02:33:25	89,70
02:33:30	89,70
02:33:35	89,70
02:33:40	89,70
02:33:45	89,70
02:33:50	89,70
02:33:55	89,70
02:34:00	89,70
02:34:05	89,70
02:34:10	89,70
02:34:15	89,70
02:34:20	89,70
02:34:25	89,70
02:34:30	89,70
02:34:35	89,70
02:34:40	89,70
02:34:45	89,80
02:34:50	89,80
02:34:55	89,80
02:35:00	89,70
02:35:05	89,70
02:35:10	89,70
02:35:15	89,70
02:35:20	89,70
02:35:25	89,70

02:35:30	89,70
02:35:35	89,70
02:35:40	89,70
02:35:45	89,70
02:35:50	89,70
02:35:55	89,70
02:36:00	89,70
02:36:05	89,70
02:36:10	89,70
02:36:15	89,70
02:36:20	89,70
02:36:25	89,70
02:36:30	89,70
02:36:35	89,70
02:36:40	89,70
02:36:45	89,70
02:36:50	89,80
02:36:55	89,80
02:37:00	89,80
02:37:05	89,70
02:37:10	89,70
02:37:15	89,70
02:37:20	89,70
02:37:25	89,70
02:37:30	89,70
02:37:35	89,70
02:37:40	89,70
02:37:45	89,70
02:37:50	89,70
02:37:55	89,80
02:38:00	89,80
02:38:05	89,80
02:38:10	89,80
02:38:15	89,80
02:38:20	89,80
02:38:25	89,80
02:38:30	89,80
02:38:35	89,80
02:38:40	89,80
02:38:45	89,80
02:38:50	89,80
02:38:55	89,80
02:39:00	89,80
02:39:05	89,80
02:39:10	89,80
02:39:15	89,80
02:39:20	89,80
02:39:25	89,80
02:39:30	89,80
02:39:35	89,80
02:39:40	89,80
02:39:45	89,80
02:39:50	89,80
02:39:55	89,80
02:40:00	89,80
02:40:05	89,80
02:40:10	89,80
02:40:15	89,80
02:40:20	89,80
02:40:25	89,80
02:40:30	89,80
02:40:35	89,90
02:40:40	89,90
02:40:45	89,90
02:40:50	89,90
02:40:55	89,80
02:41:00	89,80
02:41:05	89,90
02:41:10	89,90
02:41:15	89,90
02:41:20	89,90
02:41:25	89,90
02:41:30	89,90
02:41:35	89,90
02:41:40	89,80
02:41:45	89,80
02:41:50	89,80
02:41:55	89,80
02:42:00	89,70
02:42:05	89,70
02:42:10	89,70
02:42:15	89,70
02:42:20	89,70
02:42:25	89,70
02:42:30	89,70
02:42:35	89,70
02:42:40	89,70
02:42:45	89,70
02:42:50	89,70
02:42:55	89,70
02:43:00	89,70
02:43:05	89,80
02:43:10	89,80
02:43:15	89,80
02:43:20	89,80
02:43:25	89,80
02:43:30	89,80
02:43:35	89,80

02:43:40	89,80
02:43:45	89,70
02:43:50	89,70
02:43:55	89,70
02:44:00	89,70
02:44:05	89,70
02:44:10	89,70
02:44:15	89,70
02:44:20	89,70
02:44:25	89,70
02:44:30	89,70
02:44:35	89,70
02:44:40	89,70
02:44:45	89,70
02:44:50	89,70
02:44:55	89,70
02:45:00	89,70
02:45:05	89,70
02:45:10	89,70
02:45:15	89,70
02:45:20	89,70
02:45:25	89,70
02:45:30	89,70
02:45:35	89,70
02:45:40	89,70
02:45:45	89,70
02:45:50	89,70
02:45:55	89,70
02:46:00	89,70
02:46:05	89,70
02:46:10	89,70
02:46:15	89,70
02:46:20	89,70
02:46:25	89,70
02:46:30	89,70
02:46:35	89,70
02:46:40	89,70
02:46:45	89,70
02:46:50	89,70
02:46:55	89,70
02:47:00	89,70
02:47:05	89,70
02:47:10	89,70
02:47:15	89,70
02:47:20	89,70
02:47:25	89,70
02:47:30	89,70
02:47:35	89,70
02:47:40	89,70
02:47:45	89,70
02:47:50	89,70
02:47:55	89,70
02:48:00	89,70
02:48:05	89,70
02:48:10	89,70
02:48:15	89,70
02:48:20	89,70
02:48:25	89,70
02:48:30	89,70
02:48:35	89,70
02:48:40	89,70
02:48:45	89,70
02:48:50	89,70
02:48:55	89,70
02:49:00	89,70
02:49:05	89,70
02:49:10	89,70
02:49:15	89,70
02:49:20	89,70
02:49:25	89,70
02:49:30	89,70
02:49:35	89,70
02:49:40	89,70
02:49:45	89,70
02:49:50	89,70
02:49:55	89,70
02:50:00	89,70

02:22:50	89,20
02:22:55	88,80
02:23:00	88,40
02:23:05	88,10
02:23:10	88,00
02:23:15	88,10
02:23:20	88,20
02:23:25	88,50
02:23:30	88,70
02:23:35	89,00
02:23:40	89,00
02:23:45	89,40
02:23:50	89,40
02:23:55	89,60
02:24:00	89,40
02:24:05	89,40
02:24:10	89,30
02:24:15	89,30
02:24:20	89,30
02:24:25	89,30
02:24:30	89,30
02:24:35	89,30
02:24:40	89,30
02:24:45	89,30
02:24:50	89,20
02:24:55	89,20
02:25:00	89,30
02:25:05	89,30
02:25:10	89,30
02:25:15	89,60
02:25:20	89,70
02:25:25	89,70
02:25:30	89,80
02:25:35	89,80
02:25:40	89,90
02:25:45	89,90
02:25:50	89,90
02:25:55	89,80
02:26:00	89,70
02:26:05	89,60
02:26:10	89,60
02:26:15	89,40
02:26:20	89,40
02:26:25	89,40
02:26:30	89,60
02:26:35	89,60
02:26:40	89,70
02:26:45	89,70
02:26:50	89,80
02:26:55	89,80
02:27:00	89,90
02:27:05	89,90
02:27:10	89,80
02:27:15	89,70
02:27:20	89,70
02:27:25	89,60
02:27:30	89,60
02:27:35	89,60
02:27:40	89,60
02:27:45	89,60
02:27:50	89,70
02:27:55	89,70
02:28:00	89,70
02:28:05	89,80
02:28:10	89,80
02:28:15	89,80
02:28:20	89,80
02:28:25	89,70
02:28:30	89,70
02:28:35	89,70
02:28:40	89,70
02:28:45	89,60
02:28:50	89,60
02:28:55	89,40
02:29:00	89,40
02:29:05	89,40
02:29:10	89,40
02:29:15	89,60
02:29:20	89,60
02:29:25	89,60
02:29:30	89,60
02:29:35	89,60
02:29:40	89,60
02:29:45	89,60
02:29:50	89,60
02:29:55	89,60
02:30:00	89,60
02:30:05	89,60
02:30:10	89,60
02:30:15	89,60
02:30:20	89,60
02:30:25	89,40
02:30:30	89,40
02:30:35	89,40
02:30:40	89,40
02:30:45	89,40
02:30:50	89,40
02:30:55	89,40

02:31:00	89,40
02:31:05	89,40
02:31:10	89,40
02:31:15	89,40
02:31:20	89,40
02:31:25	89,40
02:31:30	89,40
02:31:35	89,40
02:31:40	89,40
02:31:45	89,40
02:31:50	89,40
02:31:55	89,30
02:32:00	89,30
02:32:05	89,30
02:32:10	89,30
02:32:15	89,20
02:32:20	89,20
02:32:25	89,20
02:32:30	89,20
02:32:35	89,20
02:32:40	89,20
02:32:45	89,10
02:32:50	89,10
02:32:55	89,10
02:33:00	89,20
02:33:05	89,20
02:33:10	89,20
02:33:15	89,20
02:33:20	89,20
02:33:25	89,20
02:33:30	89,20
02:33:35	89,20
02:33:40	89,20
02:33:45	89,20
02:33:50	89,10
02:33:55	89,10
02:34:00	89,10
02:34:05	89,10
02:34:10	89,10
02:34:15	89,10
02:34:20	89,10
02:34:25	89,10
02:34:30	89,10
02:34:35	89,10
02:34:40	89,10
02:34:45	89,00
02:34:50	89,00
02:34:55	89,00
02:35:00	88,90
02:35:05	88,90
02:35:10	88,90
02:35:15	88,90
02:35:20	88,90
02:35:25	88,90
02:35:30	89,00
02:35:35	89,00
02:35:40	89,00
02:35:45	89,00
02:35:50	89,00
02:35:55	89,00
02:36:00	89,00
02:36:05	89,00
02:36:10	89,00
02:36:15	89,00
02:36:20	89,00
02:36:25	89,00
02:36:30	89,00
02:36:35	89,00
02:36:40	89,00
02:36:45	89,00
02:36:50	89,00
02:36:55	89,00
02:37:00	89,00
02:37:05	89,00
02:37:10	89,00
02:37:15	89,00
02:37:20	89,00
02:37:25	89,00
02:37:30	89,00
02:37:35	89,10
02:37:40	89,10
02:37:45	89,20
02:37:50	89,20
02:37:55	89,20
02:38:00	89,30
02:38:05	89,30
02:38:10	89,30
02:38:15	89,30
02:38:20	89,30
02:38:25	89,30
02:38:30	89,30
02:38:35	89,30
02:38:40	89,30
02:38:45	89,30
02:38:50	89,30
02:38:55	89,30
02:39:00	89,30
02:39:05	89,30

02:39:10	89,30
02:39:15	89,30
02:39:20	89,30
02:39:25	89,30
02:39:30	89,40
02:39:35	89,40
02:39:40	89,40
02:39:45	89,40
02:39:50	89,40
02:39:55	89,40
02:40:00	89,40
02:40:05	89,40
02:40:10	89,30
02:40:15	89,30
02:40:20	89,30
02:40:25	89,30
02:40:30	89,30
02:40:35	89,30
02:40:40	89,30
02:40:45	89,30
02:40:50	89,30
02:40:55	89,30
02:41:00	89,40
02:41:05	89,40
02:41:10	89,40
02:41:15	89,40
02:41:20	89,40
02:41:25	89,40
02:41:30	89,40
02:41:35	89,40
02:41:40	89,40
02:41:45	89,40
02:41:50	89,40
02:41:55	89,40
02:42:00	89,40
02:42:05	89,40
02:42:10	89,40
02:42:15	89,60
02:42:20	89,40
02:42:25	89,40
02:42:30	89,40
02:42:35	89,40
02:42:40	89,30
02:42:45	89,30
02:42:50	89,30
02:42:55	89,30
02:43:00	89,30
02:43:05	89,30
02:43:10	89,30
02:43:15	89,30
02:43:20	89,30
02:43:25	89,30
02:43:30	89,30
02:43:35	89,30
02:43:40	89,30
02:43:45	89,30
02:43:50	89,30
02:43:55	89,30
02:44:00	89,30
02:44:05	89,30
02:44:10	89,30
02:44:15	89,30
02:44:20	89,30
02:44:25	89,30
02:44:30	89,30
02:44:35	89,30
02:44:40	89,30
02:44:45	89,30
02:44:50	89,30
02:44:55	89,30
02:45:00	89,30
02:45:05	89,30
02:45:10	89,30
02:45:15	89,30
02:45:20	89,30
02:45:25	89,30
02:45:30	89,30
02:45:35	89,30
02:45:40	89,30
02:45:45	89,30
02:45:50	89,30
02:45:55	89,30
02:46:00	89,30
02:46:05	89,30
02:46:10	89,30
02:46:15	89,30
02:46:20	89,30
02:46:25	89,30
02:46:30	89,30
02:46:35	89,30
02:46:40	89,30
02:46:45	89,30
02:46:50	89,40
02:46:55	89,40
02:47:00	89,40
02:47:05	89,40
02:47:10	89,40
02:47:15	89,40

02:47:20	89,40
02:47:25	89,40
02:47:30	89,40
02:47:35	89,40
02:47:40	89,40
02:47:45	89,40
02:47:50	89,40
02:47:55	89,40
02:48:00	89,40
02:48:05	89,40
02:48:10	89,40
02:48:15	89,40
02:48:20	89,40
02:48:25	89,40
02:48:30	89,40
02:48:35	89,40
02:48:40	89,40
02:48:45	89,40
02:48:50	89,40
02:48:55	89,40
02:49:00	89,40
02:49:05	89,40
02:49:10	89,40
02:49:15	89,40
02:49:20	89,40
02:49:25	89,40
02:49:30	89,40
02:49:35	89,60
02:49:40	89,60
02:49:45	89,60
02:49:50	89,60
02:49:55	89,60
02:50:00	89,60
02:50:05	89,60
02:50:10	89,40
02:50:15	89,40
02:50:20	89,40
02:50:25	89,40
02:50:30	89,40
02:50:35	89,40
02:50:40	89,40
02:50:45	89,40
02:50:50	89,40
02:50:55	89,40
02:51:00	89,40
02:51:05	89,40
02:51:10	89,40
02:51:15	89,40
02:51:20	89,40
02:51:25	89,60
02:51:30	89,60
02:51:35	89,60
02:51:40	89,60
02:51:45	89,60
02:51:50	89,60
02:51:55	89,40
02:52:00	89,40
02:52:05	89,40
02:52:10	89,40
02:52:15	89,30
02:52:20	89,30
02:52:25	89,30
02:52:30	89,30
02:52:35	89,30
02:52:40	89,30
02:52:45	89,20
02:52:50	89,20
02:52:55	89,20
02:53:00	89,30
02:53:05	89,30
02:53:10	89,30
02:53:15	89,30
02:53:20	89,30
02:53:25	89,30
02:53:30	89,30
02:53:35	89,30
02:53:40	89,30
02:53:45	89,30
02:53:50	89,30
02:53:55	89,30
02:54:00	89,30
02:54:05	89,30
02:54:10	89,30
02:54:15	89,30
02:54:20	89,30
02:54:25	89,30
02:54:30	89,30
02:54:35	89,30
02:54:40	89,30
02:54:45	89,30
02:54:50	89,30
02:54:55	89,30
02:55:00	89,30
02:55:05	89,30
02:55:10	89,30
02:55:15	89,40
02:55:20	89,40
02:55:25	89,40

02:55:30	89,40
02:55:35	89,40
02:55:40	89,40
02:55:45	89,40
02:55:50	89,30
02:55:55	89,30
02:56:00	89,30
02:56:05	89,30
02:56:10	89,30
02:56:15	89,30
02:56:20	89,30
02:56:25	89,30
02:56:30	89,30
02:56:35	89,30
02:56:40	89,30
02:56:45	89,40
02:56:50	89,40
02:56:55	89,60
02:57:00	89,60
02:57:05	89,60
02:57:10	89,60
02:57:15	89,70
02:57:20	89,70
02:57:25	89,70
02:57:30	89,70
02:57:35	89,70
02:57:40	89,60
02:57:45	89,60
02:57:50	89,40
02:57:55	89,40
02:58:00	89,40
02:58:05	89,30
02:58:10	89,30
02:58:15	89,30
02:58:20	89,30
02:58:25	89,40
02:58:30	89,40
02:58:35	89,40
02:58:40	89,40
02:58:45	89,60
02:58:50	89,50
02:58:55	89,40
02:59:00	89,40
02:59:05	89,40
02:59:10	89,40
02:59:15	89,40
02:59:20	89,40
02:59:25	89,40
02:59:30	89,30
02:59:35	89,30
02:59:40	89,30
02:59:45	89,30
02:59:50	89,30
02:59:55	89,30
03:00:00	89,30
03:00:05	89,30
03:00:10	89,30
03:00:15	89,30
03:00:20	89,30
03:00:25	89,30
03:00:30	89,30
03:00:35	89,30
03:00:40	89,30
03:00:45	89,30
03:00:50	89,30
03:00:55	89,30
03:01:00	89,30
03:01:05	89,30
03:01:10	89,30
03:01:15	89,30
03:01:20	89,30
03:01:25	89,30
03:01:30	89,30
03:01:35	89,30
03:01:40	89,30
03:01:45	89,30
03:01:50	89,30
03:01:55	89,30
03:02:00	89,30
03:02:05	89,30
03:02:10	89,30
03:02:15	89,30
03:02:20	89,30
03:02:25	89,30
03:02:30	89,40
03:02:35	89,40
03:02:40	89,40
03:02:45	89,60
03:02:50	89,60
03:02:55	89,60
03:03:00	89,60
03:03:05	89,60
03:03:10	89,60
03:03:15	89,40
03:03:20	89,40
03:03:25	89,40
03:03:30	89,40
03:03:35	89,40

03:03:40	89,60
03:03:45	89,60
03:03:50	89,60
03:03:55	89,60
03:04:00	89,60
03:04:05	89,60
03:04:10	89,70
03:04:15	89,70
03:04:20	89,70
03:04:25	89,70
03:04:30	89,70
03:04:35	89,70
03:04:40	89,70
03:04:45	89,70
03:04:50	89,60
03:04:55	89,60
03:05:00	89,60
03:05:05	89,40
03:05:10	89,40
03:05:15	89,40
03:05:20	89,40
03:05:25	89,40
03:05:30	89,40
03:05:35	89,60
03:05:40	89,60
03:05:45	89,70
03:05:50	89,70
03:05:55	89,70
03:06:00	89,70
03:06:05	89,70
03:06:10	89,60
03:06:15	89,60
03:06:20	89,40
03:06:25	89,40
03:06:30	89,40
03:06:35	89,40
03:06:40	89,30
03:06:45	89,30
03:06:50	89,30
03:06:55	89,30
03:07:00	89,30
03:07:05	89,30
03:07:10	89,30
03:07:15	89,30
03:07:20	89,30
03:07:25	89,30
03:07:30	89,30
03:07:35	89,30
03:07:40	89,30
03:07:45	89,30
03:07:50	89,30
03:07:55	89,30
03:08:00	89,30
03:08:05	89,30
03:08:10	89,30
03:08:15	89,30
03:08:20	89,30
03:08:25	89,30
03:08:30	89,30
03:08:35	89,20
03:08:40	89,20
03:08:45	89,20
03:08:50	89,20
03:08:55	89,20
03:09:00	89,20
03:09:05	89,20
03:09:10	89,20
03:09:15	89,20
03:09:20	89,20
03:09:25	89,20
03:09:30	89,20
03:09:35	89,20
03:09:40	89,20
03:09:45	89,20
03:09:50	89,30
03:09:55	89,30
03:10:00	89,30
03:10:05	89,30
03:10:10	89,30
03:10:15	89,30
03:10:20	89,30
03:10:25	89,30
03:10:30	89,30
03:10:35	89,30
03:10:40	89,20
03:10:45	89,20
03:10:50	89,30
03:10:55	89,30
03:11:00	89,30
03:11:05	89,30
03:11:10	89,30
03:11:15	89,40
03:11:20	89,40
03:11:25	89,40
03:11:30	89,40
03:11:35	89,40
03:11:40	89,40
03:11:45	89,40

03:11:50	89,40
03:11:55	89,40
03:12:00	89,40
03:12:05	89,40
03:12:10	89,40
03:12:15	89,40
03:12:20	89,40
03:12:25	89,40
03:12:30	89,40
03:12:35	89,40
03:12:40	89,60
03:12:45	89,60
03:12:50	89,60
03:12:55	89,60
03:13:00	89,60
03:13:05	89,60
03:13:10	89,60
03:13:15	89,60
03:13:20	89,60
03:13:25	89,60
03:13:30	89,60
03:13:35	89,60
03:13:40	89,60
03:13:45	89,60
03:13:50	89,60
03:13:55	89,60
03:14:00	89,60
03:14:05	89,60
03:14:10	89,60
03:14:15	89,60
03:14:20	89,60
03:14:25	89,60
03:14:30	89,60
03:14:35	89,60
03:14:40	89,70
03:14:45	89,70
03:14:50	89,70
03:14:55	89,70
03:15:00	89,60
03:15:05	89,60
03:15:10	89,60
03:15:15	89,60
03:15:20	89,40
03:15:25	89,40
03:15:30	89,40
03:15:35	89,40
03:15:40	89,40
03:15:45	89,40
03:15:50	89,40
03:15:55	89,40
03:16:00	89,40
03:16:05	89,40
03:16:10	89,40
03:16:15	89,40
03:16:20	89,40
03:16:25	89,40
03:16:30	89,40
03:16:35	89,40
03:16:40	89,40
03:16:45	89,40
03:16:50	89,40
03:16:55	89,40
03:17:00	89,40
03:17:05	89,40
03:17:10	89,40
03:17:15	89,40
03:17:20	89,30
03:17:25	89,30
03:17:30	89,30
03:17:35	89,30
03:17:40	89,30
03:17:45	89,30
03:17:50	89,30
03:17:55	89,30
03:18:00	89,30
03:18:05	89,30
03:18:10	89,30
03:18:15	89,30
03:18:20	89,30
03:18:25	89,30
03:18:30	89,30
03:18:35	89,30
03:18:40	89,30
03:18:45	89,30
03:18:50	89,40
03:18:55	89,40
03:19:00	89,40
03:19:05	89,60
03:19:10	89,60
03:19:15	89,60
03:19:20	89,70
03:19:25	89,70
03:19:30	89,70
03:19:35	89,70
03:19:40	89,70
03:19:45	89,70
03:19:50	89,70
03:19:55	89,70

03:20:00	89,70
03:20:05	89,70
03:20:10	89,70
03:20:15	89,70
03:20:20	89,70
03:20:25	89,70
03:20:30	89,70
03:20:35	89,70
03:20:40	89,70
03:20:45	89,70
03:20:50	89,70
03:20:55	89,70
03:21:00	89,70
03:21:05	89,60
03:21:10	89,60
03:21:15	89,60
03:21:20	89,60
03:21:25	89,60
03:21:30	89,60
03:21:35	89,60
03:21:40	89,70
03:21:45	89,70
03:21:50	89,70
03:21:55	89,70
03:22:00	89,70
03:22:05	89,70
03:22:10	89,70
03:22:15	89,70
03:22:20	89,70
03:22:25	89,70
03:22:30	89,70
03:22:35	89,70
03:22:40	89,70
03:22:45	89,70
03:22:50	89,60
03:22:55	89,60
03:23:00	89,40
03:23:05	89,40
03:23:10	89,40
03:23:15	89,40
03:23:20	89,40
03:23:25	89,40
03:23:30	89,40
03:23:35	89,40
03:23:40	89,60
03:23:45	89,60
03:23:50	89,60
03:23:55	89,60
03:24:00	89,60
03:24:05	89,40
03:24:10	89,40
03:24:15	89,40
03:24:20	89,40
03:24:25	89,40
03:24:30	89,40
03:24:35	89,40
03:24:40	89,40
03:24:45	89,40
03:24:50	89,40
03:24:55	89,40
03:25:00	89,30
03:25:05	89,30
03:25:10	89,30
03:25:15	89,30
03:25:20	89,30
03:25:25	89,30
03:25:30	89,30
03:25:35	89,40
03:25:40	89,40
03:25:45	89,40
03:25:50	89,40
03:25:55	89,60
03:26:00	89,60
03:26:05	89,40
03:26:10	89,40
03:26:15	89,40
03:26:20	89,40
03:26:25	89,30
03:26:30	89,30
03:26:35	89,30
03:26:40	89,30
03:26:45	89,30
03:26:50	89,30
03:26:55	89,30
03:27:00	89,30
03:27:05	89,40
03:27:10	89,40
03:27:15	89,40
03:27:20	89,40
03:27:25	89,40
03:27:30	89,30
03:27:35	89,30
03:27:40	89,40
03:27:45	89,40
03:27:50	89,40
03:27:55	89,40
03:28:00	89,40
03:28:05	89,60

03:28:10	89,60
03:28:15	89,60
03:28:20	89,70
03:28:25	89,70
03:28:30	89,70
03:28:35	89,70
03:28:40	89,60
03:28:45	89,60
03:28:50	89,60
03:28:55	89,60
03:29:00	89,60
03:29:05	89,60
03:29:10	89,60
03:29:15	89,70
03:29:20	89,70
03:29:25	89,70
03:29:30	89,70
03:29:35	89,60
03:29:40	89,60
03:29:45	89,60
03:29:50	89,40
03:29:55	89,40
03:30:00	89,40
03:30:05	89,30
03:30:10	89,30
03:30:15	89,30
03:30:20	89,40
03:30:25	89,40
03:30:30	89,40
03:30:35	89,60
03:30:40	89,60
03:30:45	89,60
03:30:50	89,60
03:30:55	89,60
03:31:00	89,60
03:31:05	89,40
03:31:10	89,40
03:31:15	89,40
03:31:20	89,40
03:31:25	89,40
03:31:30	89,40
03:31:35	89,40
03:31:40	89,40
03:31:45	89,40
03:31:50	89,40
03:31:55	89,40
03:32:00	89,40
03:32:05	89,30
03:32:10	89,30
03:32:15	89,30
03:32:20	89,30
03:32:25	89,30
03:32:30	89,30
03:32:35	89,30
03:32:40	89,30
03:32:45	89,30
03:32:50	89,30
03:32:55	89,30
03:33:00	89,30
03:33:05	89,30
03:33:10	89,30
03:33:15	89,30
03:33:20	89,30
03:33:25	89,30
03:33:30	89,30
03:33:35	89,30
03:33:40	89,30
03:33:45	89,30
03:33:50	89,30
03:33:55	89,30
03:34:00	89,30
03:34:05	89,30
03:34:10	89,30
03:34:15	89,30
03:34:20	89,30
03:34:25	89,30
03:34:30	89,20
03:34:35	89,20
03:34:40	89,20
03:34:45	89,20
03:34:50	89,20
03:34:55	89,20
03:35:00	89,30
03:35:05	89,30
03:35:10	89,30
03:35:15	89,30
03:35:20	89,30
03:35:25	89,30
03:35:30	89,30
03:35:35	89,40
03:35:40	89,40
03:35:45	89,40
03:35:50	89,40
03:35:55	89,40
03:36:00	89,60
03:36:05	89,60
03:36:10	89,40
03:36:15	89,40

03:36:20	89,40
03:36:25	89,40
03:36:30	89,40
03:36:35	89,40
03:36:40	89,40
03:36:45	89,40
03:36:50	89,40
03:36:55	89,40
03:37:00	89,60
03:37:05	89,60
03:37:10	89,60
03:37:15	89,60
03:37:20	89,60
03:37:25	89,60
03:37:30	89,60
03:37:35	89,40
03:37:40	89,40
03:37:45	89,40
03:37:50	89,40
03:37:55	89,40
03:38:00	89,40
03:38:05	89,40
03:38:10	89,30
03:38:15	89,30
03:38:20	89,30
03:38:25	89,30
03:38:30	89,30
03:38:35	89,30
03:38:40	89,30
03:38:45	89,30
03:38:50	89,30
03:38:55	89,40
03:39:00	89,40
03:39:05	89,40
03:39:10	89,40
03:39:15	89,40
03:39:20	89,40
03:39:25	89,40
03:39:30	89,40
03:39:35	89,40
03:39:40	89,40
03:39:45	89,30
03:39:50	89,30
03:39:55	89,30
03:40:00	89,30
03:40:05	89,30
03:40:10	89,30
03:40:15	89,30
03:40:20	89,30
03:40:25	89,30
03:40:30	89,30
03:40:35	89,30
03:40:40	89,30
03:40:45	89,30
03:40:50	89,30
03:40:55	89,30
03:41:00	89,30
03:41:05	89,30
03:41:10	89,30
03:41:15	89,30
03:41:20	89,30
03:41:25	89,30
03:41:30	89,30
03:41:35	89,30
03:41:40	89,30
03:41:45	89,30
03:41:50	89,30
03:41:55	89,30
03:42:00	89,30
03:42:05	89,30
03:42:10	89,30
03:42:15	89,30
03:42:20	89,30
03:42:25	89,30
03:42:30	89,30
03:42:35	89,30
03:42:40	89,30
03:42:45	89,30
03:42:50	89,30
03:42:55	89,30
03:43:00	89,30
03:43:05	89,30
03:43:10	89,30
03:43:15	89,30
03:43:20	89,30
03:43:25	89,30
03:43:30	89,30
03:43:35	89,30
03:43:40	89,30
03:43:45	89,30
03:43:50	89,30
03:43:55	89,30
03:44:00	89,30
03:44:05	89,30
03:44:10	89,30
03:44:15	89,40
03:44:20	89,40
03:44:25	89,40

03:44:30	89,40
03:44:35	89,60
03:44:40	89,60
03:44:45	89,60
03:44:50	89,60
03:44:55	89,60
03:45:00	89,60
03:45:05	89,60
03:45:10	89,60
03:45:15	89,60
03:45:20	89,60
03:45:25	89,60
03:45:30	89,60
03:45:35	89,60
03:45:40	89,60
03:45:45	89,60
03:45:50	89,60
03:45:55	89,60
03:46:00	89,60
03:46:05	89,60
03:46:10	89,60
03:46:15	89,40
03:46:20	89,40
03:46:25	89,40
03:46:30	89,40
03:46:35	89,40
03:46:40	89,40
03:46:45	89,40
03:46:50	89,40
03:46:55	89,30
03:47:00	89,30
03:47:05	89,30
03:47:10	89,30
03:47:15	89,30
03:47:20	89,30
03:47:25	89,40
03:47:30	89,40
03:47:35	89,40
03:47:40	89,40
03:47:45	89,40
03:47:50	89,40
03:47:55	89,30
03:48:00	89,30
03:48:05	89,30
03:48:10	89,30
03:48:15	89,30
03:48:20	89,30
03:48:25	89,30
03:48:30	89,30
03:48:35	89,30
03:48:40	89,30
03:48:45	89,30
03:48:50	89,30
03:48:55	89,30
03:49:00	89,30
03:49:05	89,30
03:49:10	89,30
03:49:15	89,30
03:49:20	89,30
03:49:25	89,30
03:49:30	89,30
03:49:35	89,30
03:49:40	89,30
03:49:45	89,30
03:49:50	89,30
03:49:55	89,30
03:50:00	89,30
03:50:05	89,30
03:50:10	89,30
03:50:15	89,30
03:50:20	89,30
03:50:25	89,30
03:50:30	89,30
03:50:35	89,30
03:50:40	89,30
03:50:45	89,30
03:50:50	89,30
03:50:55	89,30
03:51:00	89,30
03:51:05	89,30
03:51:10	89,30
03:51:15	89,30
03:51:20	89,30
03:51:25	89,30
03:51:30	89,30
03:51:35	89,30
03:51:40	89,30
03:51:45	89,30
03:51:50	89,30
03:51:55	89,30
03:52:00	89,30
03:52:05	89,30
03:52:10	89,30
03:52:15	89,30
03:52:20	89,30
03:52:25	89,30
03:52:30	89,30
03:52:35	89,30

03:52:40	89,30
03:52:45	89,40
03:52:50	89,60
03:52:55	89,60
03:53:00	89,70
03:53:05	89,70
03:53:10	89,70
03:53:15	89,80
03:53:20	89,80
03:53:25	89,80
03:53:30	89,70
03:53:35	89,70
03:53:40	89,70
03:53:45	89,60
03:53:50	89,60
03:53:55	89,60
03:54:00	89,60
03:54:05	89,60
03:54:10	89,40
03:54:15	89,40
03:54:20	89,40
03:54:25	89,40
03:54:30	89,40
03:54:35	89,40
03:54:40	89,40
03:54:45	89,40
03:54:50	89,40
03:54:55	89,40
03:55:00	89,60
03:55:05	89,60
03:55:10	89,60
03:55:15	89,60
03:55:20	89,40
03:55:25	89,40
03:55:30	89,60
03:55:35	89,60
03:55:40	89,60
03:55:45	89,40
03:55:50	89,40
03:55:55	89,40
03:56:00	89,40
03:56:05	89,40
03:56:10	89,30
03:56:15	89,30
03:56:20	89,30
03:56:25	89,30
03:56:30	89,30
03:56:35	89,30
03:56:40	89,30
03:56:45	89,30
03:56:50	89,30
03:56:55	89,30
03:57:00	89,30
03:57:05	89,40
03:57:10	89,40
03:57:15	89,40
03:57:20	89,40
03:57:25	89,30
03:57:30	89,30
03:57:35	89,30
03:57:40	89,30
03:57:45	89,30
03:57:50	89,30
03:57:55	89,20
03:58:00	89,20
03:58:05	89,20
03:58:10	89,20
03:58:15	89,20
03:58:20	89,20
03:58:25	89,30
03:58:30	89,30
03:58:35	89,30
03:58:40	89,30
03:58:45	89,30
03:58:50	89,40
03:58:55	89,40
03:59:00	89,40
03:59:05	89,40
03:59:10	89,40
03:59:15	89,40
03:59:20	89,40
03:59:25	89,40
03:59:30	89,40
03:59:35	89,40
03:59:40	89,40
03:59:45	89,40
03:59:50	89,40
03:59:55	89,40
04:00:00	89,40
04:00:05	89,40
04:00:10	89,40
04:00:15	89,40
04:00:20	89,60
04:00:25	89,60
04:00:30	89,70
04:00:35	89,70
04:00:40	89,70
04:00:45	89,70

04:00:50	89,80
04:00:55	89,80
04:01:00	89,80
04:01:05	89,80
04:01:10	89,80
04:01:15	89,80
04:01:20	89,80
04:01:25	89,80
04:01:30	89,80
04:01:35	89,80
04:01:40	89,80
04:01:45	89,80
04:01:50	89,80
04:01:55	89,80
04:02:00	89,80
04:02:05	89,70
04:02:10	89,70
04:02:15	89,70
04:02:20	89,70
04:02:25	89,70
04:02:30	89,70
04:02:35	89,70
04:02:40	89,80
04:02:45	89,80
04:02:50	89,70
04:02:55	89,70
04:03:00	89,70
04:03:05	89,60
04:03:10	89,60
04:03:15	89,60
04:03:20	89,60
04:03:25	89,40
04:03:30	89,40
04:03:35	89,40
04:03:40	89,40
04:03:45	89,40
04:03:50	89,60
04:03:55	89,60
04:04:00	89,60
04:04:05	89,60
04:04:10	89,60
04:04:15	89,60
04:04:20	89,60
04:04:25	89,60
04:04:30	89,40
04:04:35	89,40
04:04:40	89,40
04:04:45	89,40
04:04:50	89,40
04:04:55	89,40
04:05:00	89,30
04:05:05	89,30
04:05:10	89,30
04:05:15	89,30
04:05:20	89,30
04:05:25	89,30
04:05:30	89,30
04:05:35	89,30
04:05:40	89,30
04:05:45	89,30
04:05:50	89,30
04:05:55	89,30
04:06:00	89,30
04:06:05	89,30
04:06:10	89,30
04:06:15	89,30
04:06:20	89,30
04:06:25	89,30
04:06:30	89,30
04:06:35	89,30
04:06:40	89,30
04:06:45	89,30
04:06:50	89,30
04:06:55	89,30
04:07:00	89,30
04:07:05	89,30
04:07:10	89,20
04:07:15	89,20
04:07:20	89,30
04:07:25	89,30
04:07:30	89,30
04:07:35	89,30
04:07:40	89,30
04:07:45	89,30
04:07:50	89,30
04:07:55	89,30
04:08:00	89,30
04:08:05	89,30
04:08:10	89,30
04:08:15	89,30
04:08:20	89,30
04:08:25	89,30
04:08:30	89,30
04:08:35	89,30
04:08:40	89,40
04:08:45	89,40
04:08:50	89,40
04:08:55	89,40

04:09:00	89,40
04:09:05	89,40
04:09:10	89,50
04:09:15	89,60
04:09:20	89,60
04:09:25	89,60
04:09:30	89,60
04:09:35	89,60
04:09:40	89,60
04:09:45	89,60
04:09:50	89,60
04:09:55	89,60
04:10:00	89,60
04:10:05	89,70
04:10:10	89,70
04:10:15	89,70
04:10:20	89,70
04:10:25	89,60
04:10:30	89,60
04:10:35	89,60
04:10:40	89,60
04:10:45	89,40
04:10:50	89,40
04:10:55	89,40
04:11:00	89,40
04:11:05	89,40
04:11:10	89,40
04:11:15	89,40
04:11:20	89,40
04:11:25	89,40
04:11:30	89,40
04:11:35	89,40
04:11:40	89,50
04:11:45	89,40
04:11:50	89,40
04:11:55	89,60
04:12:00	89,60
04:12:05	89,60
04:12:10	89,60
04:12:15	89,40
04:12:20	89,40
04:12:25	89,40
04:12:30	89,40
04:12:35	89,40
04:12:40	89,40
04:12:45	89,30
04:12:50	89,30
04:12:55	89,30
04:13:00	89,30
04:13:05	89,30
04:13:10	89,30
04:13:15	89,30
04:13:20	89,30
04:13:25	89,40
04:13:30	89,40
04:13:35	89,40
04:13:40	89,40
04:13:45	89,40
04:13:50	89,40
04:13:55	89,40
04:14:00	89,30
04:14:05	89,30
04:14:10	89,30
04:14:15	89,30
04:14:20	89,30
04:14:25	89,30
04:14:30	89,30
04:14:35	89,30
04:14:40	89,30
04:14:45	89,30
04:14:50	89,30
04:14:55	89,30
04:15:00	89,30
04:15:05	89,30
04:15:10	89,30
04:15:15	89,30
04:15:20	89,30
04:15:25	89,40
04:15:30	89,40
04:15:35	89,40
04:15:40	89,40
04:15:45	89,30
04:15:50	89,30
04:15:55	89,30
04:16:00	89,30
04:16:05	89,30
04:16:10	89,30
04:16:15	89,30
04:16:20	89,40
04:16:25	89,40
04:16:30	89,40
04:16:35	89,40
04:16:40	89,50
04:16:45	89,60
04:16:50	89,60
04:16:55	89,60
04:17:00	89,60
04:17:05	89,60

04:17:10	89,60
04:17:15	89,60
04:17:20	89,60
04:17:25	89,60
04:17:30	89,70
04:17:35	89,70
04:17:40	89,70
04:17:45	89,70
04:17:50	89,70
04:17:55	89,70
04:18:00	89,70
04:18:05	89,70
04:18:10	89,70
04:18:15	89,70
04:18:20	89,70
04:18:25	89,70
04:18:30	89,70
04:18:35	89,70
04:18:40	89,70
04:18:45	89,70
04:18:50	89,70
04:18:55	89,70
04:19:00	89,70
04:19:05	89,70
04:19:10	89,70
04:19:15	89,70
04:19:20	89,70
04:19:25	89,70
04:19:30	89,70
04:19:35	89,70
04:19:40	89,70
04:19:45	89,70
04:19:50	89,70
04:19:55	89,70
04:20:00	89,70
04:20:05	89,60
04:20:10	89,60
04:20:15	89,60
04:20:20	89,60
04:20:25	89,60
04:20:30	89,60
04:20:35	89,60
04:20:40	89,60
04:20:45	89,70
04:20:50	89,70
04:20:55	89,70
04:21:00	89,70
04:21:05	89,70
04:21:10	89,60
04:21:15	89,60
04:21:20	89,40
04:21:25	89,40
04:21:30	89,40
04:21:35	89,30
04:21:40	89,30
04:21:45	89,30
04:21:50	89,30
04:21:55	89,40
04:22:00	89,40
04:22:05	89,40
04:22:10	89,40
04:22:15	89,40
04:22:20	89,40
04:22:25	89,40
04:22:30	89,40
04:22:35	89,40
04:22:40	89,40
04:22:45	89,40
04:22:50	89,40
04:22:55	89,30
04:23:00	89,30
04:23:05	89,30
04:23:10	89,30
04:23:15	89,30
04:23:20	89,30
04:23:25	89,30
04:23:30	89,30
04:23:35	89,30
04:23:40	89,30
04:23:45	89,30
04:23:50	89,30
04:23:55	89,30
04:24:00	89,30
04:24:05	89,30
04:24:10	89,30
04:24:15	89,30
04:24:20	89,30
04:24:25	89,30
04:24:30	89,30
04:24:35	89,40
04:24:40	89,40
04:24:45	89,40
04:24:50	89,50
04:24:55	89,50
04:25:00	89,60
04:25:05	89,60
04:25:10	89,60
04:25:15	89,60

04:25:20	89,50
04:25:25	89,40
04:25:30	89,40
04:25:35	89,40
04:25:40	89,40
04:25:45	89,40
04:25:50	89,40
04:25:55	89,40
04:26:00	89,40
04:26:05	89,60
04:26:10	89,60
04:26:15	89,60
04:26:20	89,60
04:26:25	89,60
04:26:30	89,60
04:26:35	89,60
04:26:40	89,60
04:26:45	89,60
04:26:50	89,60
04:26:55	89,60
04:27:00	89,40
04:27:05	89,40
04:27:10	89,40
04:27:15	89,40
04:27:20	89,40
04:27:25	89,40
04:27:30	89,40
04:27:35	89,30
04:27:40	89,30
04:27:45	89,30
04:27:50	89,40
04:27:55	89,40
04:28:00	89,40
04:28:05	89,40
04:28:10	89,40
04:28:15	89,40
04:28:20	89,40
04:28:25	89,40
04:28:30	89,40
04:28:35	89,40
04:28:40	89,40
04:28:45	89,30
04:28:50	89,30
04:28:55	89,30
04:29:00	89,30
04:29:05	89,30
04:29:10	89,30
04:29:15	89,30
04:29:20	89,30
04:29:25	89,30
04:29:30	89,30
04:29:35	89,30
04:29:40	89,30
04:29:45	89,30
04:29:50	89,30
04:29:55	89,30
04:30:00	89,30
04:30:05	89,30
04:30:10	89,30
04:30:15	89,30
04:30:20	89,30
04:30:25	89,30
04:30:30	89,30
04:30:35	89,30
04:30:40	89,30
04:30:45	89,30
04:30:50	89,30
04:30:55	89,30
04:31:00	89,30
04:31:05	89,30
04:31:10	89,30
04:31:15	89,30
04:31:20	89,30
04:31:25	89,30
04:31:30	89,30
04:31:35	89,20
04:31:40	89,20
04:31:45	89,20
04:31:50	89,20
04:31:55	89,20
04:32:00	89,20
04:32:05	89,20
04:32:10	89,30
04:32:15	89,30
04:32:20	89,30
04:32:25	89,30
04:32:30	89,30
04:32:35	89,30
04:32:40	89,40
04:32:45	89,40
04:32:50	89,40
04:32:55	89,60
04:33:00	89,60
04:33:05	89,60
04:33:10	89,60
04:33:15	89,60
04:33:20	89,60
04:33:25	89,60

04:33:30	89,60
04:33:35	89,70
04:33:40	89,70
04:33:45	89,70
04:33:50	89,70
04:33:55	89,70
04:34:00	89,70
04:34:05	89,80
04:34:10	89,80
04:34:15	89,80
04:34:20	89,80
04:34:25	89,70
04:34:30	89,70
04:34:35	89,70
04:34:40	89,60
04:34:45	89,60
04:34:50	89,60
04:34:55	89,60
04:35:00	89,60
04:35:05	89,60
04:35:10	89,60
04:35:15	89,60
04:35:20	89,60
04:35:25	89,60
04:35:30	89,70
04:35:35	89,70
04:35:40	89,70
04:35:45	89,70
04:35:50	89,70
04:35:55	89,70
04:36:00	89,70
04:36:05	89,70
04:36:10	89,70
04:36:15	89,70
04:36:20	89,60
04:36:25	89,60
04:36:30	89,60
04:36:35	89,40
04:36:40	89,40
04:36:45	89,40
04:36:50	89,40
04:36:55	89,40
04:37:00	89,40
04:37:05	89,40
04:37:10	89,40
04:37:15	89,60
04:37:20	89,60
04:37:25	89,60
04:37:30	89,60
04:37:35	89,60
04:37:40	89,60
04:37:45	89,60
04:37:50	89,60
04:37:55	89,40
04:38:00	89,40
04:38:05	89,40
04:38:10	89,40
04:38:15	89,40
04:38:20	89,30
04:38:25	89,30
04:38:30	89,30
04:38:35	89,30
04:38:40	89,30
04:38:45	89,30
04:38:50	89,30
04:38:55	89,30
04:39:00	89,30
04:39:05	89,40
04:39:10	89,40
04:39:15	89,40
04:39:20	89,40
04:39:25	89,40
04:39:30	89,40
04:39:35	89,40
04:39:40	89,30
04:39:45	89,30
04:39:50	89,30
04:39:55	89,30
04:40:00	89,30
04:40:05	89,30
04:40:10	89,30
04:40:15	89,30
04:40:20	89,30
04:40:25	89,30
04:40:30	89,30
04:40:35	89,40
04:40:40	89,50
04:40:45	89,60
04:40:50	89,60
04:40:55	89,70
04:41:00	89,70
04:41:05	89,70
04:41:10	89,70
04:41:15	89,70
04:41:20	89,70
04:41:25	89,70
04:41:30	89,70
04:41:35	89,70

04:41:40	89,70
04:41:45	89,70
04:41:50	89,70
04:41:55	89,70
04:42:00	89,70
04:42:05	89,70
04:42:10	89,70
04:42:15	89,70
04:42:20	89,70
04:42:25	89,70
04:42:30	89,70
04:42:35	89,70
04:42:40	89,60
04:42:45	89,60
04:42:50	89,60
04:42:55	89,60
04:43:00	89,60
04:43:05	89,60
04:43:10	89,60
04:43:15	89,60
04:43:20	89,60
04:43:25	89,60
04:43:30	89,60
04:43:35	89,60
04:43:40	89,70
04:43:45	89,70
04:43:50	89,70
04:43:55	89,70
04:44:00	89,70
04:44:05	89,60
04:44:10	89,60
04:44:15	89,60
04:44:20	89,60
04:44:25	89,60
04:44:30	89,60
04:44:35	89,60
04:44:40	89,60
04:44:45	89,60
04:44:50	89,40
04:44:55	89,40
04:45:00	89,40
04:45:05	89,40
04:45:10	89,40
04:45:15	89,40
04:45:20	89,40
04:45:25	89,40
04:45:30	89,40
04:45:35	89,40
04:45:40	89,40
04:45:45	89,40
04:45:50	89,30
04:45:55	89,30
04:46:00	89,30
04:46:05	89,40
04:46:10	89,40
04:46:15	89,40
04:46:20	89,40
04:46:25	89,40
04:46:30	89,40
04:46:35	89,40
04:46:40	89,40
04:46:45	89,40
04:46:50	89,40
04:46:55	89,40
04:47:00	89,40
04:47:05	89,40
04:47:10	89,40
04:47:15	89,40
04:47:20	89,40
04:47:25	89,40
04:47:30	89,30
04:47:35	89,30
04:47:40	89,30
04:47:45	89,30
04:47:50	89,30
04:47:55	89,30
04:48:00	89,30
04:48:05	89,30
04:48:10	89,30
04:48:15	89,30
04:48:20	89,30
04:48:25	89,40
04:48:30	89,40
04:48:35	89,40
04:48:40	89,40
04:48:45	89,40
04:48:50	89,40
04:48:55	89,40
04:49:00	89,60
04:49:05	89,60
04:49:10	89,60
04:49:15	89,60
04:49:20	89,60
04:49:25	89,60
04:49:30	89,60
04:49:35	89,60
04:49:40	89,60
04:49:45	89,70

04:49:50	89,70
04:49:55	89,70
04:50:00	89,70
04:50:05	89,70
04:50:10	89,70
04:50:15	89,70
04:50:20	89,70
04:50:25	89,70
04:50:30	89,70
04:50:35	89,70
04:50:40	89,70
04:50:45	89,70
04:50:50	89,70
04:50:55	89,70
04:51:00	89,70
04:51:05	89,70
04:51:10	89,70
04:51:15	89,70
04:51:20	89,70
04:51:25	89,60
04:51:30	89,60
04:51:35	89,60
04:51:40	89,60
04:51:45	89,40
04:51:50	89,40
04:51:55	89,40
04:52:00	89,40
04:52:05	89,40
04:52:10	89,40
04:52:15	89,40
04:52:20	89,40
04:52:25	89,40
04:52:30	89,40
04:52:35	89,40
04:52:40	89,40
04:52:45	89,40
04:52:50	89,40
04:52:55	89,40
04:53:00	89,40
04:53:05	89,40
04:53:10	89,40
04:53:15	89,40
04:53:20	89,40
04:53:25	89,40
04:53:30	89,40
04:53:35	89,40
04:53:40	89,40
04:53:45	89,40
04:53:50	89,40
04:53:55	89,40
04:54:00	89,40
04:54:05	89,40
04:54:10	89,60
04:54:15	89,60
04:54:20	89,40
04:54:25	89,40
04:54:30	89,40
04:54:35	89,60
04:54:40	89,60
04:54:45	89,60
04:54:50	89,60
04:54:55	89,40
04:55:00	89,40
04:55:05	89,40
04:55:10	89,40
04:55:15	89,40
04:55:20	89,40
04:55:25	89,40
04:55:30	89,40
04:55:35	89,40
04:55:40	89,40
04:55:45	89,40
04:55:50	89,40
04:55:55	89,40
04:56:00	89,40
04:56:05	89,40
04:56:10	89,40
04:56:15	89,40
04:56:20	89,60
04:56:25	89,60
04:56:30	89,60
04:56:35	89,60
04:56:40	89,60
04:56:45	89,70
04:56:50	89,70
04:56:55	89,70
04:57:00	89,70
04:57:05	89,70
04:57:10	89,70
04:57:15	89,70
04:57:20	89,70
04:57:25	89,70
04:57:30	89,70
04:57:35	89,70
04:57:40	89,70
04:57:45	89,70
04:57:50	89,70
04:57:55	89,70

04:58:00	89,70
04:58:05	89,70
04:58:10	89,70
04:58:15	89,60
04:58:20	89,60
04:58:25	89,60
04:58:30	89,60
04:58:35	89,60
04:58:40	89,70
04:58:45	89,70
04:58:50	89,70
04:58:55	89,70
04:59:00	89,60
04:59:05	89,60
04:59:10	89,60
04:59:15	89,60
04:59:20	89,60
04:59:25	89,60
04:59:30	89,40
04:59:35	89,40
04:59:40	89,40
04:59:45	89,40
04:59:50	89,40
04:59:55	89,40
05:00:00	89,40
05:00:05	89,40
05:00:10	89,40
05:00:15	89,40
05:00:20	89,40
05:00:25	89,40
05:00:30	89,40
05:00:35	89,40
05:00:40	89,40
05:00:45	89,40
05:00:50	89,40
05:00:55	89,40
05:01:00	89,40
05:01:05	89,40
05:01:10	89,40
05:01:15	89,40
05:01:20	89,40
05:01:25	89,40
05:01:30	89,40
05:01:35	89,40
05:01:40	89,40
05:01:45	89,40
05:01:50	89,40
05:01:55	89,40
05:02:00	89,30
05:02:05	89,30
05:02:10	89,30
05:02:15	89,40
05:02:20	89,30
05:02:25	89,30
05:02:30	89,40
05:02:35	89,40
05:02:40	89,40
05:02:45	89,40
05:02:50	89,40
05:02:55	89,40
05:03:00	89,40
05:03:05	89,40
05:03:10	89,40
05:03:15	89,40
05:03:20	89,40
05:03:25	89,40
05:03:30	89,40
05:03:35	89,40
05:03:40	89,40
05:03:45	89,40
05:03:50	89,40
05:03:55	89,40
05:04:00	89,40
05:04:05	89,40
05:04:10	89,40
05:04:15	89,40
05:04:20	89,60
05:04:25	89,60
05:04:30	89,60
05:04:35	89,60
05:04:40	89,60
05:04:45	89,70
05:04:50	89,70
05:04:55	89,70
05:05:00	89,70
05:05:05	89,70
05:05:10	89,70
05:05:15	89,70
05:05:20	89,70
05:05:25	89,70
05:05:30	89,70
05:05:35	89,70
05:05:40	89,70
05:05:45	89,70
05:05:50	89,70
05:05:55	89,70
05:06:00	89,70
05:06:05	89,70

05:06:10	89,70
05:06:15	89,70
05:06:20	89,70
05:06:25	89,70
05:06:30	89,70
05:06:35	89,70
05:06:40	89,70
05:06:45	89,70
05:06:50	89,70
05:06:55	89,70
05:07:00	89,70
05:07:05	89,70
05:07:10	89,60
05:07:15	89,60
05:07:20	89,60
05:07:25	89,60
05:07:30	89,60
05:07:35	89,60
05:07:40	89,40
05:07:45	89,40
05:07:50	89,40
05:07:55	89,40
05:08:00	89,40
05:08:05	89,40
05:08:10	89,40
05:08:15	89,40
05:08:20	89,40
05:08:25	89,40
05:08:30	89,50
05:08:35	89,60
05:08:40	89,60
05:08:45	89,40
05:08:50	89,40
05:08:55	89,40
05:09:00	89,40
05:09:05	89,40
05:09:10	89,30
05:09:15	89,30
05:09:20	89,30
05:09:25	89,30
05:09:30	89,30
05:09:35	89,30
05:09:40	89,30
05:09:45	89,30
05:09:50	89,30
05:09:55	89,30
05:10:00	89,30
05:10:05	89,40
05:10:10	89,40
05:10:15	89,40
05:10:20	89,40
05:10:25	89,40
05:10:30	89,40
05:10:35	89,40
05:10:40	89,40
05:10:45	89,40
05:10:50	89,40
05:10:55	89,40
05:11:00	89,40
05:11:05	89,40
05:11:10	89,30
05:11:15	89,30
05:11:20	89,30
05:11:25	89,30
05:11:30	89,30
05:11:35	89,30
05:11:40	89,30
05:11:45	89,40
05:11:50	89,40
05:11:55	89,40
05:12:00	89,60
05:12:05	89,60
05:12:10	89,70
05:12:15	89,70
05:12:20	89,70
05:12:25	89,70
05:12:30	89,70
05:12:35	89,70
05:12:40	89,70
05:12:45	89,70
05:12:50	89,70
05:12:55	89,80
05:13:00	89,80
05:13:05	89,80
05:13:10	89,80
05:13:15	89,80
05:13:20	89,70
05:13:25	89,70
05:13:30	89,70
05:13:35	89,70
05:13:40	89,70
05:13:45	89,70
05:13:50	89,70
05:13:55	89,70
05:14:00	89,70
05:14:05	89,70
05:14:10	89,70
05:14:15	89,70

05:14:20	89,70
05:14:25	89,70
05:14:30	89,70
05:14:35	89,70
05:14:40	89,70
05:14:45	89,70
05:14:50	89,70
05:14:55	89,70
05:15:00	89,70
05:15:05	89,70
05:15:10	89,70
05:15:15	89,70
05:15:20	89,70
05:15:25	89,60
05:15:30	89,60
05:15:35	89,60
05:15:40	89,60
05:15:45	89,60
05:15:50	89,60
05:15:55	89,60
05:16:00	89,60
05:16:05	89,60
05:16:10	89,60
05:16:15	89,60
05:16:20	89,60
05:16:25	89,60
05:16:30	89,60
05:16:35	89,60
05:16:40	89,60
05:16:45	89,40
05:16:50	89,40
05:16:55	89,40
05:17:00	89,40
05:17:05	89,40
05:17:10	89,40
05:17:15	89,40
05:17:20	89,40
05:17:25	89,40
05:17:30	89,40
05:17:35	89,30
05:17:40	89,30
05:17:45	89,30
05:17:50	89,30
05:17:55	89,30
05:18:00	89,30
05:18:05	89,30
05:18:10	89,30
05:18:15	89,30
05:18:20	89,30
05:18:25	89,40
05:18:30	89,40
05:18:35	89,40
05:18:40	89,40
05:18:45	89,40
05:18:50	89,40
05:18:55	89,40
05:19:00	89,60
05:19:05	89,60
05:19:10	89,60
05:19:15	89,60
05:19:20	89,60
05:19:25	89,60
05:19:30	89,60
05:19:35	89,60
05:19:40	89,60
05:19:45	89,60
05:19:50	89,60
05:19:55	89,60
05:20:00	89,70
05:20:05	89,70
05:20:10	89,70
05:20:15	89,70
05:20:20	89,70
05:20:25	89,80
05:20:30	89,80
05:20:35	89,80
05:20:40	89,80
05:20:45	89,80
05:20:50	89,80
05:20:55	89,80
05:21:00	89,80
05:21:05	89,70
05:21:10	89,70
05:21:15	89,70
05:21:20	89,70
05:21:25	89,70
05:21:30	89,60
05:21:35	89,60
05:21:40	89,60
05:21:45	89,60
05:21:50	89,60
05:21:55	89,60
05:22:00	89,70
05:22:05	89,70
05:22:10	89,70
05:22:15	89,70
05:22:20	89,70
05:22:25	89,70

05:22:30	89,70
05:22:35	89,70
05:22:40	89,70
05:22:45	89,70
05:22:50	89,70
05:22:55	89,70
05:23:00	89,60
05:23:05	89,60
05:23:10	89,60
05:23:15	89,60
05:23:20	89,60
05:23:25	89,60
05:23:30	89,40
05:23:35	89,40
05:23:40	89,40
05:23:45	89,40
05:23:50	89,40
05:23:55	89,60
05:24:00	89,60
05:24:05	89,60
05:24:10	89,60
05:24:15	89,60
05:24:20	89,60
05:24:25	89,60
05:24:30	89,40
05:24:35	89,40
05:24:40	89,40
05:24:45	89,40
05:24:50	89,40
05:24:55	89,40
05:25:00	89,30
05:25:05	89,30
05:25:10	89,30
05:25:15	89,30
05:25:20	89,30
05:25:25	89,30
05:25:30	89,40
05:25:35	89,40
05:25:40	89,40
05:25:45	89,40
05:25:50	89,40
05:25:55	89,40
05:26:00	89,30
05:26:05	89,30
05:26:10	89,30
05:26:15	89,30
05:26:20	89,30
05:26:25	89,30
05:26:30	89,30
05:26:35	89,30
05:26:40	89,30
05:26:45	89,30
05:26:50	89,30
05:26:55	89,30
05:27:00	89,30
05:27:05	89,30
05:27:10	89,30
05:27:15	89,40
05:27:20	89,40
05:27:25	89,60
05:27:30	89,60
05:27:35	89,60
05:27:40	89,60
05:27:45	89,60
05:27:50	89,60
05:27:55	89,60
05:28:00	89,60
05:28:05	89,60
05:28:10	89,60
05:28:15	89,60
05:28:20	89,60
05:28:25	89,60
05:28:30	89,60
05:28:35	89,60
05:28:40	89,60
05:28:45	89,60
05:28:50	89,60
05:28:55	89,60
05:29:00	89,60
05:29:05	89,60
05:29:10	89,60
05:29:15	89,60
05:29:20	89,60
05:29:25	89,60
05:29:30	89,60
05:29:35	89,70
05:29:40	89,70
05:29:45	89,70
05:29:50	89,70
05:29:55	89,70
05:30:00	89,70
05:30:05	89,70
05:30:10	89,70
05:30:15	89,70
05:30:20	89,70
05:30:25	89,70
05:30:30	89,70
05:30:35	89,70

05:30:40	89,70
05:30:45	89,70
05:30:50	89,70
05:30:55	89,70
05:31:00	89,70
05:31:05	89,70
05:31:10	89,70
05:31:15	89,70
05:31:20	89,70
05:31:25	89,70
05:31:30	89,70
05:31:35	89,70
05:31:40	89,70
05:31:45	89,70
05:31:50	89,70
05:31:55	89,70
05:32:00	89,70
05:32:05	89,60
05:32:10	89,60
05:32:15	89,60
05:32:20	89,60
05:32:25	89,40
05:32:30	89,40
05:32:35	89,40
05:32:40	89,40
05:32:45	89,40
05:32:50	89,40
05:32:55	89,40
05:33:00	89,40
05:33:05	89,40
05:33:10	89,40
05:33:15	89,40
05:33:20	89,60
05:33:25	89,60
05:33:30	89,60
05:33:35	89,70
05:33:40	89,70
05:33:45	89,70
05:33:50	89,60
05:33:55	89,60
05:34:00	89,60
05:34:05	89,40
05:34:10	89,40
05:34:15	89,40
05:34:20	89,40
05:34:25	89,40
05:34:30	89,40
05:34:35	89,60
05:34:40	89,60
05:34:45	89,70
05:34:50	89,70
05:34:55	89,70
05:35:00	89,70
05:35:05	89,70
05:35:10	89,70
05:35:15	89,70
05:35:20	89,70
05:35:25	89,70
05:35:30	89,70
05:35:35	89,70
05:35:40	89,70
05:35:45	89,70
05:35:50	89,70
05:35:55	89,70
05:36:00	89,70
05:36:05	89,70
05:36:10	89,70
05:36:15	89,70
05:36:20	89,70
05:36:25	89,70
05:36:30	89,70
05:36:35	89,80
05:36:40	89,80
05:36:45	89,80
05:36:50	89,80
05:36:55	89,70
05:37:00	89,70
05:37:05	89,70
05:37:10	89,70
05:37:15	89,70
05:37:20	89,60
05:37:25	89,60
05:37:30	89,40
05:37:35	89,40
05:37:40	89,40
05:37:45	89,40
05:37:50	89,40
05:37:55	89,40
05:38:00	89,40
05:38:05	89,40
05:38:10	89,40
05:38:15	89,40
05:38:20	89,40
05:38:25	89,40
05:38:30	89,40
05:38:35	89,40
05:38:40	89,30
05:38:45	89,30

05:38:50	89,30
05:38:55	89,30
05:39:00	89,30
05:39:05	89,30
05:39:10	89,30
05:39:15	89,30
05:39:20	89,30
05:39:25	89,30
05:39:30	89,30
05:39:35	89,30
05:39:40	89,30
05:39:45	89,30
05:39:50	89,30
05:39:55	89,30
05:40:00	89,30
05:40:05	89,30
05:40:10	89,30
05:40:15	89,30
05:40:20	89,30
05:40:25	89,30
05:40:30	89,30
05:40:35	89,30
05:40:40	89,30
05:40:45	89,30
05:40:50	89,30
05:40:55	89,30
05:41:00	89,30
05:41:05	89,30
05:41:10	89,30
05:41:15	89,30
05:41:20	89,30
05:41:25	89,30
05:41:30	89,30
05:41:35	89,30
05:41:40	89,30
05:41:45	89,20
05:41:50	89,20
05:41:55	89,20
05:42:00	89,30
05:42:05	89,30
05:42:10	89,30
05:42:15	89,30
05:42:20	89,30
05:42:25	89,30
05:42:30	89,30
05:42:35	89,40
05:42:40	89,40
05:42:45	89,40
05:42:50	89,40
05:42:55	89,40
05:43:00	89,40
05:43:05	89,40
05:43:10	89,40
05:43:15	89,40
05:43:20	89,40
05:43:25	89,50
05:43:30	89,60
05:43:35	89,60
05:43:40	89,60
05:43:45	89,60
05:43:50	89,70
05:43:55	89,70
05:44:00	89,70
05:44:05	89,70
05:44:10	89,70
05:44:15	89,70
05:44:20	89,70
05:44:25	89,70
05:44:30	89,70
05:44:35	89,70
05:44:40	89,60
05:44:45	89,60
05:44:50	89,60
05:44:55	89,70
05:45:00	89,70
05:45:05	89,70
05:45:10	89,70
05:45:15	89,70
05:45:20	89,70
05:45:25	89,70
05:45:30	89,70
05:45:35	89,70
05:45:40	89,60
05:45:45	89,60
05:45:50	89,70
05:45:55	89,70
05:46:00	89,70
05:46:05	89,70
05:46:10	89,70
05:46:15	89,70
05:46:20	89,70
05:46:25	89,70
05:46:30	89,70
05:46:35	89,70
05:46:40	89,70
05:46:45	89,70
05:46:50	89,70
05:46:55	89,70

05:47:00	89,70
05:47:05	89,70
05:47:10	89,70
05:47:15	89,70
05:47:20	89,60
05:47:25	89,60
05:47:30	89,60
05:47:35	89,60
05:47:40	89,60
05:47:45	89,60
05:47:50	89,60
05:47:55	89,60
05:48:00	89,60
05:48:05	89,60
05:48:10	89,60
05:48:15	89,60
05:48:20	89,60
05:48:25	89,60
05:48:30	89,60
05:48:35	89,60
05:48:40	89,60
05:48:45	89,60
05:48:50	89,60
05:48:55	89,60
05:49:00	89,60
05:49:05	89,60
05:49:10	89,60
05:49:15	89,70
05:49:20	89,70
05:49:25	89,70
05:49:30	89,60
05:49:35	89,60
05:49:40	89,60
05:49:45	89,60
05:49:50	89,60
05:49:55	89,60
05:50:00	89,60
05:50:05	89,60
05:50:10	89,60
05:50:15	89,70
05:50:20	89,70
05:50:25	89,70
05:50:30	89,70
05:50:35	89,70
05:50:40	89,70
05:50:45	89,70
05:50:50	89,70
05:50:55	89,70
05:51:00	89,70
05:51:05	89,70
05:51:10	89,70
05:51:15	89,70
05:51:20	89,80
05:51:25	89,80
05:51:30	89,80
05:51:35	89,80
05:51:40	89,70
05:51:45	89,70
05:51:50	89,70
05:51:55	89,70
05:52:00	89,70
05:52:05	89,70
05:52:10	89,70
05:52:15	89,70
05:52:20	89,70
05:52:25	89,70
05:52:30	89,70
05:52:35	89,70
05:52:40	89,70
05:52:45	89,70
05:52:50	89,70
05:52:55	89,70
05:53:00	89,70
05:53:05	89,70
05:53:10	89,70
05:53:15	89,70
05:53:20	89,70
05:53:25	89,70
05:53:30	89,70
05:53:35	89,70
05:53:40	89,70
05:53:45	89,70
05:53:50	89,60
05:53:55	89,60
05:54:00	89,60
05:54:05	89,40
05:54:10	89,40
05:54:15	89,40
05:54:20	89,40
05:54:25	89,40
05:54:30	89,40
05:54:35	89,30
05:54:40	89,30
05:54:45	89,30
05:54:50	89,30
05:54:55	89,30
05:55:00	89,30
05:55:05	89,30

05:55:10	89,30
05:55:15	89,30
05:55:20	89,30
05:55:25	89,30
05:55:30	89,30
05:55:35	89,30
05:55:40	89,30
05:55:45	89,30
05:55:50	89,30
05:55:55	89,30
05:56:00	89,30
05:56:05	89,30
05:56:10	89,30
05:56:15	89,30
05:56:20	89,30
05:56:25	89,30
05:56:30	89,30
05:56:35	89,30
05:56:40	89,30
05:56:45	89,30
05:56:50	89,30
05:56:55	89,30
05:57:00	89,30
05:57:05	89,30
05:57:10	89,30
05:57:15	89,30
05:57:20	89,30
05:57:25	89,30
05:57:30	89,30
05:57:35	89,30
05:57:40	89,30
05:57:45	89,30
05:57:50	89,30
05:57:55	89,30
05:58:00	89,40
05:58:05	89,40
05:58:10	89,40
05:58:15	89,40
05:58:20	89,40
05:58:25	89,60
05:58:30	89,60
05:58:35	89,60
05:58:40	89,60
05:58:45	89,60
05:58:50	89,60
05:58:55	89,60
05:59:00	89,60
05:59:05	89,60
05:59:10	89,60
05:59:15	89,60
05:59:20	89,60
05:59:25	89,40
05:59:30	89,40
05:59:35	89,40
05:59:40	89,30
05:59:45	89,30
05:59:50	89,30
05:59:55	89,30
06:00:00	89,30
06:00:05	89,30
06:00:10	89,30
06:00:15	89,40
06:00:20	89,40
06:00:25	89,40
06:00:30	89,40
06:00:35	89,40
06:00:40	89,40
06:00:45	89,40
06:00:50	89,40
06:00:55	89,40
06:01:00	89,40
06:01:05	89,40
06:01:10	89,40
06:01:15	89,30
06:01:20	89,30
06:01:25	89,30
06:01:30	89,30
06:01:35	89,30
06:01:40	89,30
06:01:45	89,30
06:01:50	89,30
06:01:55	89,30
06:02:00	89,30
06:02:05	89,30
06:02:10	89,40
06:02:15	89,40
06:02:20	89,40
06:02:25	89,40
06:02:30	89,40
06:02:35	89,30
06:02:40	89,30
06:02:45	89,30
06:02:50	89,30
06:02:55	89,30
06:03:00	89,30
06:03:05	89,30
06:03:10	89,30
06:03:15	89,30

06:03:20	89,30
06:03:25	89,30
06:03:30	89,30
06:03:35	89,30
06:03:40	89,30
06:03:45	89,30
06:03:50	89,30
06:03:55	89,30
06:04:00	89,30
06:04:05	89,30
06:04:10	89,30
06:04:15	89,30
06:04:20	89,30
06:04:25	89,30
06:04:30	89,30
06:04:35	89,30
06:04:40	89,30
06:04:45	89,30
06:04:50	89,30
06:04:55	89,30
06:05:00	89,30
06:05:05	89,30
06:05:10	89,30
06:05:15	89,30
06:05:20	89,30
06:05:25	89,40
06:05:30	89,40
06:05:35	89,40
06:05:40	89,40
06:05:45	89,40
06:05:50	89,60
06:05:55	89,60
06:06:00	89,60
06:06:05	89,60
06:06:10	89,70
06:06:15	89,70
06:06:20	89,70
06:06:25	89,70
06:06:30	89,70
06:06:35	89,70
06:06:40	89,70
06:06:45	89,70
06:06:50	89,70
06:06:55	89,70
06:07:00	89,70
06:07:05	89,70
06:07:10	89,70
06:07:15	89,70
06:07:20	89,70
06:07:25	89,70
06:07:30	89,70
06:07:35	89,70
06:07:40	89,60
06:07:45	89,60
06:07:50	89,60
06:07:55	89,60
06:08:00	89,60
06:08:05	89,60
06:08:10	89,60
06:08:15	89,60
06:08:20	89,60
06:08:25	89,40
06:08:30	89,40
06:08:35	89,40
06:08:40	89,40
06:08:45	89,60
06:08:50	89,60
06:08:55	89,60
06:09:00	89,60
06:09:05	89,40
06:09:10	89,40
06:09:15	89,40
06:09:20	89,40
06:09:25	89,40
06:09:30	89,30
06:09:35	89,30
06:09:40	89,30
06:09:45	89,30
06:09:50	89,30
06:09:55	89,30
06:10:00	89,30
06:10:05	89,30
06:10:10	89,30
06:10:15	89,30
06:10:20	89,30
06:10:25	89,30
06:10:30	89,30
06:10:35	89,30
06:10:40	89,30
06:10:45	89,30
06:10:50	89,30
06:10:55	89,20
06:11:00	89,20
06:11:05	89,20
06:11:10	89,20
06:11:15	89,20
06:11:20	89,20
06:11:25	89,30

06:11:30	89,30
06:11:35	89,30
06:11:40	89,30
06:11:45	89,30
06:11:50	89,30
06:11:55	89,30
06:12:00	89,30
06:12:05	89,30
06:12:10	89,30
06:12:15	89,30
06:12:20	89,30
06:12:25	89,30
06:12:30	89,30
06:12:35	89,30
06:12:40	89,30
06:12:45	89,30
06:12:50	89,30
06:12:55	89,30
06:13:00	89,40
06:13:05	89,40
06:13:10	89,40
06:13:15	89,40
06:13:20	89,60
06:13:25	89,60
06:13:30	89,60
06:13:35	89,60
06:13:40	89,60
06:13:45	89,70
06:13:50	89,70
06:13:55	89,70
06:14:00	89,70
06:14:05	89,70
06:14:10	89,70
06:14:15	89,70
06:14:20	89,70
06:14:25	89,70
06:14:30	89,70
06:14:35	89,70
06:14:40	89,70
06:14:45	89,70
06:14:50	89,70
06:14:55	89,70
06:15:00	89,70
06:15:05	89,70
06:15:10	89,60
06:15:15	89,60
06:15:20	89,60
06:15:25	89,40
06:15:30	89,40
06:15:35	89,40
06:15:40	89,40
06:15:45	89,40
06:15:50	89,40
06:15:55	89,40
06:16:00	89,40
06:16:05	89,40
06:16:10	89,40
06:16:15	89,40
06:16:20	89,40
06:16:25	89,40
06:16:30	89,40
06:16:35	89,40
06:16:40	89,30
06:16:45	89,30
06:16:50	89,30
06:16:55	89,30
06:17:00	89,30
06:17:05	89,30
06:17:10	89,30
06:17:15	89,30
06:17:20	89,30
06:17:25	89,30
06:17:30	89,30
06:17:35	89,30
06:17:40	89,30
06:17:45	89,30
06:17:50	89,30
06:17:55	89,30
06:18:00	89,30
06:18:05	89,30
06:18:10	89,30
06:18:15	89,30
06:18:20	89,30
06:18:25	89,20
06:18:30	89,20
06:18:35	89,20
06:18:40	89,20
06:18:45	89,30
06:18:50	89,30
06:18:55	89,30
06:19:00	89,30
06:19:05	89,30
06:19:10	89,30
06:19:15	89,30
06:19:20	89,30
06:19:25	89,30
06:19:30	89,30
06:19:35	89,30

06:19:40	89,30
06:19:45	89,30
06:19:50	89,30
06:19:55	89,30
06:20:00	89,30
06:20:05	89,30
06:20:10	89,30
06:20:15	89,30
06:20:20	89,30
06:20:25	89,30
06:20:30	89,30
06:20:35	89,30
06:20:40	89,30
06:20:45	89,30
06:20:50	89,40
06:20:55	89,40
06:21:00	89,40
06:21:05	89,40
06:21:10	89,50
06:21:15	89,60
06:21:20	89,60
06:21:25	89,60
06:21:30	89,70
06:21:35	89,70
06:21:40	89,70
06:21:45	89,70
06:21:50	89,70
06:21:55	89,70
06:22:00	89,70
06:22:05	89,70
06:22:10	89,70
06:22:15	89,60
06:22:20	89,60
06:22:25	89,60
06:22:30	89,60
06:22:35	89,60
06:22:40	89,60
06:22:45	89,60
06:22:50	89,60
06:22:55	89,60
06:23:00	89,60
06:23:05	89,60
06:23:10	89,60
06:23:15	89,60
06:23:20	89,60
06:23:25	89,60
06:23:30	89,60
06:23:35	89,60
06:23:40	89,60
06:23:45	89,60
06:23:50	89,60
06:23:55	89,60
06:24:00	89,60
06:24:05	89,40
06:24:10	89,60
06:24:15	89,60
06:24:20	89,60
06:24:25	89,60
06:24:30	89,60
06:24:35	89,60
06:24:40	89,60
06:24:45	89,60
06:24:50	89,60
06:24:55	89,60
06:25:00	89,60
06:25:05	89,60
06:25:10	89,40
06:25:15	89,40
06:25:20	89,40
06:25:25	89,40
06:25:30	89,40
06:25:35	89,40
06:25:40	89,40
06:25:45	89,40
06:25:50	89,60
06:25:55	89,60
06:26:00	89,60
06:26:05	89,60
06:26:10	89,60
06:26:15	89,60
06:26:20	89,60
06:26:25	89,60
06:26:30	89,60
06:26:35	89,60
06:26:40	89,60
06:26:45	89,60
06:26:50	89,60
06:26:55	89,60
06:27:00	89,60
06:27:05	89,60
06:27:10	89,60
06:27:15	89,60
06:27:20	89,60
06:27:25	89,60
06:27:30	89,60
06:27:35	89,60
06:27:40	89,40
06:27:45	89,40

06:27:50	89,40
06:27:55	89,40
06:28:00	89,40
06:28:05	89,60
06:28:10	89,60
06:28:15	89,60
06:28:20	89,70
06:28:25	89,70
06:28:30	89,70
06:28:35	89,70
06:28:40	89,70
06:28:45	89,70
06:28:50	89,70
06:28:55	89,70
06:29:00	89,70
06:29:05	89,70
06:29:10	89,70
06:29:15	89,70
06:29:20	89,70
06:29:25	89,70
06:29:30	89,70
06:29:35	89,70
06:29:40	89,70
06:29:45	89,70
06:29:50	89,70
06:29:55	89,70
06:30:00	89,60
06:30:05	89,60
06:30:10	89,60
06:30:15	89,60
06:30:20	89,60
06:30:25	89,60
06:30:30	89,40
06:30:35	89,40
06:30:40	89,40
06:30:45	89,40
06:30:50	89,60
06:30:55	89,40
06:31:00	89,40
06:31:05	89,40
06:31:10	89,40
06:31:15	89,40
06:31:20	89,40
06:31:25	89,40
06:31:30	89,40
06:31:35	89,40
06:31:40	89,40
06:31:45	89,40
06:31:50	89,40
06:31:55	89,40
06:32:00	89,40
06:32:05	89,40
06:32:10	89,30
06:32:15	89,30
06:32:20	89,30
06:32:25	89,30
06:32:30	89,30
06:32:35	89,30
06:32:40	89,30
06:32:45	89,30
06:32:50	89,30
06:32:55	89,30
06:33:00	89,30
06:33:05	89,30
06:33:10	89,30
06:33:15	89,30
06:33:20	89,30
06:33:25	89,30
06:33:30	89,30
06:33:35	89,30
06:33:40	89,30
06:33:45	89,30
06:33:50	89,30
06:33:55	89,30
06:34:00	89,40
06:34:05	89,40
06:34:10	89,30
06:34:15	89,30
06:34:20	89,30
06:34:25	89,30
06:34:30	89,30
06:34:35	89,30
06:34:40	89,30
06:34:45	89,30
06:34:50	89,30
06:34:55	89,30
06:35:00	89,30
06:35:05	89,30
06:35:10	89,40
06:35:15	89,40
06:35:20	89,40
06:35:25	89,60
06:35:30	89,60
06:35:35	89,60
06:35:40	89,60
06:35:45	89,60
06:35:50	89,60
06:35:55	89,70

06:36:00	89,70
06:36:05	89,70
06:36:10	89,70
06:36:15	89,70
06:36:20	89,70
06:36:25	89,70
06:36:30	89,70
06:36:35	89,70
06:36:40	89,70
06:36:45	89,80
06:36:50	89,80
06:36:55	89,80
06:37:00	89,80
06:37:05	89,80
06:37:10	89,80
06:37:15	89,70
06:37:20	89,70
06:37:25	89,70
06:37:30	89,70
06:37:35	89,70
06:37:40	89,70
06:37:45	89,70
06:37:50	89,70
06:37:55	89,70
06:38:00	89,70
06:38:05	89,60
06:38:10	89,60
06:38:15	89,60
06:38:20	89,60
06:38:25	89,60
06:38:30	89,60
06:38:35	89,60
06:38:40	89,60
06:38:45	89,60
06:38:50	89,40
06:38:55	89,40
06:39:00	89,40
06:39:05	89,40
06:39:10	89,40
06:39:15	89,30
06:39:20	89,30
06:39:25	89,30
06:39:30	89,30
06:39:35	89,30
06:39:40	89,30
06:39:45	89,30
06:39:50	89,30
06:39:55	89,30
06:40:00	89,30
06:40:05	89,30
06:40:10	89,30
06:40:15	89,30
06:40:20	89,30
06:40:25	89,30
06:40:30	89,30
06:40:35	89,30
06:40:40	89,20
06:40:45	89,20
06:40:50	89,20
06:40:55	89,20
06:41:00	89,20
06:41:05	89,30
06:41:10	89,30
06:41:15	89,30
06:41:20	89,30
06:41:25	89,30
06:41:30	89,30
06:41:35	89,30
06:41:40	89,30
06:41:45	89,30
06:41:50	89,30
06:41:55	89,30
06:42:00	89,30
06:42:05	89,30
06:42:10	89,30
06:42:15	89,30
06:42:20	89,30
06:42:25	89,30
06:42:30	89,30
06:42:35	89,30
06:42:40	89,30
06:42:45	89,30
06:42:50	89,30
06:42:55	89,30
06:43:00	89,30
06:43:05	89,30
06:43:10	89,40
06:43:15	89,40
06:43:20	89,60
06:43:25	89,60
06:43:30	89,70
06:43:35	89,70
06:43:40	89,70
06:43:45	89,70
06:43:50	89,70
06:43:55	89,70
06:44:00	89,70
06:44:05	89,70

06:44:10	89,70
06:44:15	89,70
06:44:20	89,70
06:44:25	89,70
06:44:30	89,70
06:44:35	89,70
06:44:40	89,70
06:44:45	89,70
06:44:50	89,70
06:44:55	89,70
06:45:00	89,70
06:45:05	89,70
06:45:10	89,70
06:45:15	89,70
06:45:20	89,70
06:45:25	89,70
06:45:30	89,70
06:45:35	89,70
06:45:40	89,60
06:45:45	89,60
06:45:50	89,60
06:45:55	89,60
06:46:00	89,60
06:46:05	89,60
06:46:10	89,60
06:46:15	89,70
06:46:20	89,70
06:46:25	89,70
06:46:30	89,70
06:46:35	89,70
06:46:40	89,70
06:46:45	89,70
06:46:50	89,70
06:46:55	89,70
06:47:00	89,70
06:47:05	89,70
06:47:10	89,70
06:47:15	89,60
06:47:20	89,60
06:47:25	89,60
06:47:30	89,40
06:47:35	89,40
06:47:40	89,40
06:47:45	89,40
06:47:50	89,30
06:47:55	89,30
06:48:00	89,30
06:48:05	89,40
06:48:10	89,40
06:48:15	89,40
06:48:20	89,40
06:48:25	89,60
06:48:30	89,60
06:48:35	89,60
06:48:40	89,60
06:48:45	89,40
06:48:50	89,40
06:48:55	89,40
06:49:00	89,40
06:49:05	89,40
06:49:10	89,40
06:49:15	89,40
06:49:20	89,40
06:49:25	89,40
06:49:30	89,40
06:49:35	89,40
06:49:40	89,40
06:49:45	89,40
06:49:50	89,40
06:49:55	89,40
06:50:00	89,40
06:50:05	89,50
06:50:10	89,60
06:50:15	89,60
06:50:20	89,70
06:50:25	89,70
06:50:30	89,70
06:50:35	89,70
06:50:40	89,70
06:50:45	89,80
06:50:50	89,80
06:50:55	89,80
06:51:00	89,80
06:51:05	89,80
06:51:10	89,80
06:51:15	89,80
06:51:20	89,80
06:51:25	89,70
06:51:30	89,70
06:51:35	89,80
06:51:40	89,80
06:51:45	89,80
06:51:50	89,80
06:51:55	89,80
06:52:00	89,80
06:52:05	89,80
06:52:10	89,80
06:52:15	89,70

06:52:20	89,70
06:52:25	89,70
06:52:30	89,70
06:52:35	89,70
06:52:40	89,70
06:52:45	89,70
06:52:50	89,70
06:52:55	89,60
06:53:00	89,60
06:53:05	89,60
06:53:10	89,60
06:53:15	89,60
06:53:20	89,60
06:53:25	89,60
06:53:30	89,60
06:53:35	89,60
06:53:40	89,60
06:53:45	89,60
06:53:50	89,60
06:53:55	89,60
06:54:00	89,60
06:54:05	89,60
06:54:10	89,60
06:54:15	89,50
06:54:20	89,40
06:54:25	89,40
06:54:30	89,40
06:54:35	89,40
06:54:40	89,40
06:54:45	89,40
06:54:50	89,40
06:54:55	89,40
06:55:00	89,40
06:55:05	89,40
06:55:10	89,40
06:55:15	89,40
06:55:20	89,40
06:55:25	89,40
06:55:30	89,40
06:55:35	89,40
06:55:40	89,40
06:55:45	89,30
06:55:50	89,30
06:55:55	89,30
06:56:00	89,30
06:56:05	89,30
06:56:10	89,30
06:56:15	89,30
06:56:20	89,30
06:56:25	89,30
06:56:30	89,30
06:56:35	89,30
06:56:40	89,30
06:56:45	89,30
06:56:50	89,30
06:56:55	89,30
06:57:00	89,30
06:57:05	89,30
06:57:10	89,30
06:57:15	89,30
06:57:20	89,30
06:57:25	89,30
06:57:30	89,30
06:57:35	89,30
06:57:40	89,30
06:57:45	89,30
06:57:50	89,30
06:57:55	89,30
06:58:00	89,30
06:58:05	89,40
06:58:10	89,40
06:58:15	89,60
06:58:20	89,60
06:58:25	89,70
06:58:30	89,70
06:58:35	89,70
06:58:40	89,70
06:58:45	89,70
06:58:50	89,70
06:58:55	89,70
06:59:00	89,70
06:59:05	89,70
06:59:10	89,60
06:59:15	89,60
06:59:20	89,60
06:59:25	89,60
06:59:30	89,60
06:59:35	89,60
06:59:40	89,60
06:59:45	89,60
06:59:50	89,60
06:59:55	89,60
07:00:00	89,60
07:00:05	89,60
07:00:10	89,40
07:00:15	89,40
07:00:20	89,40
07:00:25	89,40

07:00:30	89,40
07:00:35	89,40
07:00:40	89,40
07:00:45	89,40
07:00:50	89,40
07:00:55	89,40
07:01:00	89,40
07:01:05	89,40
07:01:10	89,40
07:01:15	89,40
07:01:20	89,40
07:01:25	89,40
07:01:30	89,30
07:01:35	89,30
07:01:40	89,30
07:01:45	89,30
07:01:50	89,30
07:01:55	89,30
07:02:00	89,30
07:02:05	89,30
07:02:10	89,30
07:02:15	89,30
07:02:20	89,30
07:02:25	89,30
07:02:30	89,30
07:02:35	89,30
07:02:40	89,30
07:02:45	89,30
07:02:50	89,30
07:02:55	89,30
07:03:00	89,30
07:03:05	89,30
07:03:10	89,30
07:03:15	89,30
07:03:20	89,30
07:03:25	89,30
07:03:30	89,30
07:03:35	89,30
07:03:40	89,30
07:03:45	89,30
07:03:50	89,30
07:03:55	89,30
07:04:00	89,30
07:04:05	89,30
07:04:10	89,30
07:04:15	89,30
07:04:20	89,40
07:04:25	89,40
07:04:30	89,40
07:04:35	89,40
07:04:40	89,40
07:04:45	89,40
07:04:50	89,60
07:04:55	89,60
07:05:00	89,60
07:05:05	89,60
07:05:10	89,60
07:05:15	89,70
07:05:20	89,70
07:05:25	89,70
07:05:30	89,70
07:05:35	89,70
07:05:40	89,70
07:05:45	89,70
07:05:50	89,70
07:05:55	89,70
07:06:00	89,70
07:06:05	89,80
07:06:10	89,80
07:06:15	89,80
07:06:20	89,80
07:06:25	89,80
07:06:30	89,80
07:06:35	89,80
07:06:40	89,80
07:06:45	89,80
07:06:50	89,80
07:06:55	89,80
07:07:00	89,80
07:07:05	89,70
07:07:10	89,70
07:07:15	89,70
07:07:20	89,70
07:07:25	89,70
07:07:30	89,70
07:07:35	89,70
07:07:40	89,70
07:07:45	89,70
07:07:50	89,70
07:07:55	89,70
07:08:00	89,70
07:08:05	89,70
07:08:10	89,70
07:08:15	89,70
07:08:20	89,70
07:08:25	89,70
07:08:30	89,70
07:08:35	89,70

07:08:40	89,70
07:08:45	89,60
07:08:50	89,60
07:08:55	89,60
07:09:00	89,60
07:09:05	89,60
07:09:10	89,40
07:09:15	89,40
07:09:20	89,40
07:09:25	89,60
07:09:30	89,60
07:09:35	89,60
07:09:40	89,60
07:09:45	89,60
07:09:50	89,60
07:09:55	89,60
07:10:00	89,60
07:10:05	89,60
07:10:10	89,40
07:10:15	89,40
07:10:20	89,40
07:10:25	89,30
07:10:30	89,30
07:10:35	89,30
07:10:40	89,30
07:10:45	89,30
07:10:50	89,30
07:10:55	89,30
07:11:00	89,30
07:11:05	89,30
07:11:10	89,30
07:11:15	89,30
07:11:20	89,30
07:11:25	89,40
07:11:30	89,40
07:11:35	89,40
07:11:40	89,40
07:11:45	89,40
07:11:50	89,40
07:11:55	89,40
07:12:00	89,40
07:12:05	89,40
07:12:10	89,40
07:12:15	89,40
07:12:20	89,40
07:12:25	89,40
07:12:30	89,40
07:12:35	89,60
07:12:40	89,60
07:12:45	89,60
07:12:50	89,60
07:12:55	89,70
07:13:00	89,70
07:13:05	89,70
07:13:10	89,70
07:13:15	89,70
07:13:20	89,70
07:13:25	89,70
07:13:30	89,70
07:13:35	89,70
07:13:40	89,70
07:13:45	89,70
07:13:50	89,70
07:13:55	89,70
07:14:00	89,60
07:14:05	89,60
07:14:10	89,60
07:14:15	89,60
07:14:20	89,60
07:14:25	89,60
07:14:30	89,60
07:14:35	89,60
07:14:40	89,60
07:14:45	89,40
07:14:50	89,40
07:14:55	89,40
07:15:00	89,70

20:17:50	90,70
20:17:55	90,60
20:18:00	90,60
20:18:05	90,50
20:18:10	90,50
20:18:15	90,50
20:18:20	90,40
20:18:25	90,40
20:18:30	90,40
20:18:35	90,30
20:18:40	90,30
20:18:45	90,30
20:18:50	90,20
20:18:55	90,20
20:19:00	90,20
20:19:05	90,20
20:19:10	90,20
20:19:15	90,10
20:19:20	90,10
20:19:25	90,10
20:19:30	90,10
20:19:35	90,10
20:19:40	90,00
20:19:45	90,00
20:19:50	90,00
20:19:55	90,00
20:20:00	89,90
20:20:05	89,90
20:20:10	89,90
20:20:15	89,90
20:20:20	89,80
20:20:25	89,80
20:20:30	89,70
20:20:35	89,70
20:20:40	89,60
20:20:45	89,60
20:20:50	89,60
20:20:55	89,60
20:21:00	89,50
20:21:05	89,50
20:21:10	89,50
20:21:15	89,50
20:21:20	89,50
20:21:25	89,50
20:21:30	89,50
20:21:35	89,40
20:21:40	89,40
20:21:45	89,30
20:21:50	89,30
20:21:55	89,20
20:22:00	89,20
20:22:05	89,20
20:22:10	89,20
20:22:15	89,20
20:22:20	89,20
20:22:25	89,10
20:22:30	89,10
20:22:35	89,20
20:22:40	89,20
20:22:45	89,20
20:22:50	89,10
20:22:55	89,10
20:23:00	89,10
20:23:05	89,10
20:23:10	89,10
20:23:15	89,10
20:23:20	89,10
20:23:25	89,00
20:23:30	89,00
20:23:35	89,00
20:23:40	89,00
20:23:45	89,00
20:23:50	89,00
20:23:55	89,00
20:24:00	89,00
20:24:05	89,00
20:24:10	89,00
20:24:15	89,00
20:24:20	89,00
20:24:25	89,00
20:24:30	89,00
20:24:35	89,00
20:24:40	89,00
20:24:45	89,00
20:24:50	89,00
20:24:55	89,10
20:25:00	89,00
20:25:05	89,00
20:25:10	89,00
20:25:15	89,00
20:25:20	89,00
20:25:25	89,00
20:25:30	89,00
20:25:35	89,10
20:25:40	89,10
20:25:45	89,10
20:25:50	89,10
20:25:55	89,10

20:26:00	89,20
20:26:05	89,20
20:26:10	89,20
20:26:15	89,20
20:26:20	89,20
20:26:25	89,20
20:26:30	89,20
20:26:35	89,20
20:26:40	89,20
20:26:45	89,20
20:26:50	89,20
20:26:55	89,20
20:27:00	89,20
20:27:05	89,20
20:27:10	89,20
20:27:15	89,20
20:27:20	89,30
20:27:25	89,30
20:27:30	89,30
20:27:35	89,30
20:27:40	89,30
20:27:45	89,40
20:27:50	89,40
20:27:55	89,40
20:28:00	89,40
20:28:05	89,40
20:28:10	89,40
20:28:15	89,40
20:28:20	89,50
20:28:25	89,50
20:28:30	89,50
20:28:35	89,50
20:28:40	89,50
20:28:45	89,50
20:28:50	89,50
20:28:55	89,50
20:29:00	89,50
20:29:05	89,50
20:29:10	89,50
20:29:15	89,50
20:29:20	89,60
20:29:25	89,60
20:29:30	89,60
20:29:35	89,60
20:29:40	89,60
20:29:45	89,60
20:29:50	89,60
20:29:55	89,70
20:30:00	89,70
20:30:05	89,70
20:30:10	89,70
20:30:15	89,80
20:30:20	89,80
20:30:25	89,80
20:30:30	89,80
20:30:35	89,80
20:30:40	89,80
20:30:45	89,90
20:30:50	89,90
20:30:55	89,90
20:31:00	89,80
20:31:05	89,80
20:31:10	89,80
20:31:15	89,80
20:31:20	89,80
20:31:25	89,80
20:31:30	89,80
20:31:35	89,80
20:31:40	89,80
20:31:45	89,80
20:31:50	89,80
20:31:55	89,80
20:32:00	89,80
20:32:05	89,80
20:32:10	89,80
20:32:15	89,90
20:32:20	89,90
20:32:25	89,90
20:32:30	89,90
20:32:35	89,90
20:32:40	89,90
20:32:45	89,90
20:32:50	89,90
20:32:55	89,90
20:33:00	89,90
20:33:05	89,90
20:33:10	89,90
20:33:15	89,90
20:33:20	89,90
20:33:25	89,90
20:33:30	89,90
20:33:35	89,90
20:33:40	89,90
20:33:45	89,90
20:33:50	89,90
20:33:55	89,90
20:34:00	89,90
20:34:05	89,80

20:34:10	89,80
20:34:15	89,80
20:34:20	89,90
20:34:25	89,90
20:34:30	89,90
20:34:35	89,90
20:34:40	89,90
20:34:45	89,90
20:34:50	89,90
20:34:55	89,90
20:35:00	90,00
20:35:05	90,00
20:35:10	90,00
20:35:15	90,00
20:35:20	90,00
20:35:25	90,00
20:35:30	90,00
20:35:35	90,10
20:35:40	90,10
20:35:45	90,10
20:35:50	90,10
20:35:55	90,10
20:36:00	90,20
20:36:05	90,20
20:36:10	90,20
20:36:15	90,20
20:36:20	90,20
20:36:25	90,20
20:36:30	90,20
20:36:35	90,20
20:36:40	90,20
20:36:45	90,20
20:36:50	90,20
20:36:55	90,20
20:37:00	90,20
20:37:05	90,20
20:37:10	90,20
20:37:15	90,20
20:37:20	90,20
20:37:25	90,20
20:37:30	90,20
20:37:35	90,20
20:37:40	90,20
20:37:45	90,20
20:37:50	90,20
20:37:55	90,20
20:38:00	90,20
20:38:05	90,20
20:38:10	90,20
20:38:15	90,20
20:38:20	90,20
20:38:25	90,20
20:38:30	90,20
20:38:35	90,20
20:38:40	90,20
20:38:45	90,20
20:38:50	90,20
20:38:55	90,20
20:39:00	90,20
20:39:05	90,20
20:39:10	90,20
20:39:15	90,20
20:39:20	90,20
20:39:25	90,20
20:39:30	90,20
20:39:35	90,20
20:39:40	90,20
20:39:45	90,20
20:39:50	90,10
20:39:55	90,10
20:40:00	90,10
20:40:05	90,20
20:40:10	90,10
20:40:15	90,10
20:40:20	90,10
20:40:25	90,10
20:40:30	90,10
20:40:35	90,10
20:40:40	90,10
20:40:45	90,10
20:40:50	90,10
20:40:55	90,10
20:41:00	90,10
20:41:05	90,10
20:41:10	90,10
20:41:15	90,10
20:41:20	90,10
20:41:25	90,10
20:41:30	90,10
20:41:35	90,10
20:41:40	90,10
20:41:45	90,10
20:41:50	90,10
20:41:55	90,10
20:42:00	90,10
20:42:05	90,10
20:42:10	90,10
20:42:15	90,10

20:42:20	90,10
20:42:25	90,10
20:42:30	90,10
20:42:35	90,10
20:42:40	90,10
20:42:45	90,20
20:42:50	90,20
20:42:55	90,20
20:43:00	90,20
20:43:05	90,20
20:43:10	90,20
20:43:15	90,20
20:43:20	90,20
20:43:25	90,20
20:43:30	90,20
20:43:35	90,20
20:43:40	90,20
20:43:45	90,20
20:43:50	90,20
20:43:55	90,20
20:44:00	90,20
20:44:05	90,20
20:44:10	90,10
20:44:15	90,10
20:44:20	90,10
20:44:25	90,10
20:44:30	90,10
20:44:35	90,10
20:44:40	90,10
20:44:45	90,10
20:44:50	90,10
20:44:55	90,10
20:45:00	90,10
20:45:05	90,10
20:45:10	90,20
20:45:15	90,20
20:45:20	90,20
20:45:25	90,20
20:45:30	90,20
20:45:35	90,20
20:45:40	90,20
20:45:45	90,20
20:45:50	90,20
20:45:55	90,20
20:46:00	90,20
20:46:05	90,20
20:46:10	90,20
20:46:15	90,20
20:46:20	90,20
20:46:25	90,20
20:46:30	90,20
20:46:35	90,20
20:46:40	90,20
20:46:45	90,20
20:46:50	90,30
20:46:55	90,30
20:47:00	90,30
20:47:05	90,30
20:47:10	90,30
20:47:15	90,30
20:47:20	90,30
20:47:25	90,30
20:47:30	90,30
20:47:35	90,30
20:47:40	90,30
20:47:45	90,30
20:47:50	90,30
20:47:55	90,30
20:48:00	90,30
20:48:05	90,30
20:48:10	90,30
20:48:15	90,30
20:48:20	90,30
20:48:25	90,30
20:48:30	90,30
20:48:35	90,30
20:48:40	90,30
20:48:45	90,30
20:48:50	90,30
20:48:55	90,30
20:49:00	90,30
20:49:05	90,30
20:49:10	90,30
20:49:15	90,30
20:49:20	90,30
20:49:25	90,30
20:49:30	90,30
20:49:35	90,30
20:49:40	90,30
20:49:45	90,30
20:49:50	90,30
20:49:55	90,30
20:50:00	90,30
20:50:05	90,30
20:50:10	90,30
20:50:15	90,30
20:50:20	90,30
20:50:25	90,30

20:50:30	90,30
20:50:35	90,30
20:50:40	90,30
20:50:45	90,30
20:50:50	90,30
20:50:55	90,30
20:51:00	90,30
20:51:05	90,30
20:51:10	90,30
20:51:15	90,30
20:51:20	90,30
20:51:25	90,30
20:51:30	90,30
20:51:35	90,30
20:51:40	90,30
20:51:45	90,30
20:51:50	90,30
20:51:55	90,30
20:52:00	90,30
20:52:05	90,30
20:52:10	90,40
20:52:15	90,40
20:52:20	90,40
20:52:25	90,40
20:52:30	90,40
20:52:35	90,40
20:52:40	90,40
20:52:45	90,40
20:52:50	90,40
20:52:55	90,40
20:53:00	90,40
20:53:05	90,40
20:53:10	90,40
20:53:15	90,40
20:53:20	90,50
20:53:25	90,50
20:53:30	90,50
20:53:35	90,50
20:53:40	90,60
20:53:45	90,60
20:53:50	90,60
20:53:55	90,60
20:54:00	90,60
20:54:05	90,60
20:54:10	90,60
20:54:15	90,50
20:54:20	90,50
20:54:25	90,50
20:54:30	90,60
20:54:35	90,60
20:54:40	90,60
20:54:45	90,60
20:54:50	90,60
20:54:55	90,60
20:55:00	90,60
20:55:05	90,60
20:55:10	90,60
20:55:15	90,60
20:55:20	90,60
20:55:25	90,60
20:55:30	90,60
20:55:35	90,60
20:55:40	90,60
20:55:45	90,60
20:55:50	90,60
20:55:55	90,60
20:56:00	90,60
20:56:05	90,60
20:56:10	90,60
20:56:15	90,60
20:56:20	90,60
20:56:25	90,60
20:56:30	90,60
20:56:35	90,60
20:56:40	90,60
20:56:45	90,50
20:56:50	90,50
20:56:55	90,50
20:57:00	90,50
20:57:05	90,50
20:57:10	90,50
20:57:15	90,50
20:57:20	90,50
20:57:25	90,50
20:57:30	90,50
20:57:35	90,50
20:57:40	90,50
20:57:45	90,50
20:57:50	90,50
20:57:55	90,50
20:58:00	90,50
20:58:05	90,50
20:58:10	90,50
20:58:15	90,50
20:58:20	90,50
20:58:25	90,50
20:58:30	90,50
20:58:35	90,50

20:58:40	90,40
20:58:45	90,40
20:58:50	90,40
20:58:55	90,40
20:59:00	90,40
20:59:05	90,40
20:59:10	90,40
20:59:15	90,40
20:59:20	90,40
20:59:25	90,40
20:59:30	90,40
20:59:35	90,30
20:59:40	90,30
20:59:45	90,30
20:59:50	90,30
20:59:55	90,30
21:00:00	90,30
21:00:05	90,30
21:00:10	90,20
21:00:15	90,20
21:00:20	90,20
21:00:25	90,20
21:00:30	90,20
21:00:35	90,20
21:00:40	90,20
21:00:45	90,20
21:00:50	90,20
21:00:55	90,20
21:01:00	90,20
21:01:05	90,10
21:01:10	90,10
21:01:15	90,10
21:01:20	90,10
21:01:25	90,10
21:01:30	90,10
21:01:35	90,10
21:01:40	90,10
21:01:45	90,10
21:01:50	90,10
21:01:55	90,10
21:02:00	90,10
21:02:05	90,10
21:02:10	90,10
21:02:15	90,10
21:02:20	90,10
21:02:25	90,10
21:02:30	90,10
21:02:35	90,10
21:02:40	90,10
21:02:45	90,10
21:02:50	90,10
21:02:55	90,00
21:03:00	90,00
21:03:05	90,00
21:03:10	90,00
21:03:15	90,00
21:03:20	90,00
21:03:25	90,00
21:03:30	90,00
21:03:35	90,00
21:03:40	90,00
21:03:45	90,00
21:03:50	90,00
21:03:55	90,00
21:04:00	90,00
21:04:05	90,00
21:04:10	90,00
21:04:15	90,00
21:04:20	90,00
21:04:25	90,00
21:04:30	90,00
21:04:35	90,00
21:04:40	90,00
21:04:45	90,00
21:04:50	90,00
21:04:55	90,00
21:05:00	90,00
21:05:05	89,90
21:05:10	89,90
21:05:15	89,90
21:05:20	89,90
21:05:25	89,90
21:05:30	89,90
21:05:35	90,00
21:05:40	90,00
21:05:45	90,00
21:05:50	90,00
21:05:55	90,00
21:06:00	90,00
21:06:05	90,00
21:06:10	90,00
21:06:15	90,00
21:06:20	90,10
21:06:25	90,10
21:06:30	90,10
21:06:35	90,10
21:06:40	90,10
21:06:45	90,10

21:06:50	90,10
21:06:55	90,10
21:07:00	90,10
21:07:05	90,10
21:07:10	90,10
21:07:15	90,10
21:07:20	90,10
21:07:25	90,10
21:07:30	90,10
21:07:35	90,10
21:07:40	90,10
21:07:45	90,10
21:07:50	90,10
21:07:55	90,10
21:08:00	90,10
21:08:05	90,10
21:08:10	90,10
21:08:15	90,10
21:08:20	90,10
21:08:25	90,10
21:08:30	90,10
21:08:35	90,10
21:08:40	90,10
21:08:45	90,10
21:08:50	90,10
21:08:55	90,10
21:09:00	90,10
21:09:05	90,10
21:09:10	90,10
21:09:15	90,00
21:09:20	90,10
21:09:25	90,10
21:09:30	90,10
21:09:35	90,10
21:09:40	90,10
21:09:45	90,10
21:09:50	90,10
21:09:55	90,10
21:10:00	90,00
21:10:05	90,00
21:10:10	90,10
21:10:15	90,10
21:10:20	90,10
21:10:25	90,00
21:10:30	90,00
21:10:35	90,00
21:10:40	90,00
21:10:45	90,00
21:10:50	90,00
21:10:55	90,00
21:11:00	90,00
21:11:05	90,00
21:11:10	90,00
21:11:15	90,00
21:11:20	90,00
21:11:25	90,00
21:11:30	90,00
21:11:35	90,00
21:11:40	90,00
21:11:45	90,00
21:11:50	90,00
21:11:55	90,00
21:12:00	90,00
21:12:05	90,00
21:12:10	90,10
21:12:15	90,00
21:12:20	90,10
21:12:25	90,10
21:12:30	90,10
21:12:35	90,00
21:12:40	90,10
21:12:45	90,10
21:12:50	90,10
21:12:55	90,10
21:13:00	90,10
21:13:05	90,10
21:13:10	90,10
21:13:15	90,10
21:13:20	90,10
21:13:25	90,10
21:13:30	90,10
21:13:35	90,10
21:13:40	90,10
21:13:45	90,10
21:13:50	90,10
21:13:55	90,10
21:14:00	90,10
21:14:05	90,20
21:14:10	90,20
21:14:15	90,20
21:14:20	90,20
21:14:25	90,20
21:14:30	90,20
21:14:35	90,20
21:14:40	90,20
21:14:45	90,20
21:14:50	90,20
21:14:55	90,20

21:15:00	90,20
21:15:05	90,20
21:15:10	90,20
21:15:15	90,20
21:15:20	90,20
21:15:25	90,20
21:15:30	90,20
21:15:35	90,20
21:15:40	90,20
21:15:45	90,10
21:15:50	90,10
21:15:55	90,10
21:16:00	90,10
21:16:05	90,10
21:16:10	90,10
21:16:15	90,20
21:16:20	90,20
21:16:25	90,20
21:16:30	90,20
21:16:35	90,10
21:16:40	90,10
21:16:45	90,10
21:16:50	90,10
21:16:55	90,10
21:17:00	90,10
21:17:05	90,10
21:17:10	90,10
21:17:15	90,10
21:17:20	90,20
21:17:25	90,20
21:17:30	90,20
21:17:35	90,20
21:17:40	90,20
21:17:45	90,20
21:17:50	90,20
21:17:55	90,10
21:18:00	90,10
21:18:05	90,10
21:18:10	90,10
21:18:15	90,10
21:18:20	90,10
21:18:25	90,10
21:18:30	90,10
21:18:35	90,10
21:18:40	90,10
21:18:45	90,10
21:18:50	90,10
21:18:55	90,10
21:19:00	90,10
21:19:05	90,10
21:19:10	90,10
21:19:15	90,10
21:19:20	90,10
21:19:25	90,10
21:19:30	90,10
21:19:35	90,10
21:19:40	90,10
21:19:45	90,10
21:19:50	90,10
21:19:55	90,10
21:20:00	90,10
21:20:05	90,10
21:20:10	90,10
21:20:15	90,10
21:20:20	90,10
21:20:25	90,10
21:20:30	90,10
21:20:35	90,10
21:20:40	90,10
21:20:45	90,10
21:20:50	90,10
21:20:55	90,10
21:21:00	90,10
21:21:05	90,10
21:21:10	90,10
21:21:15	90,10
21:21:20	90,10
21:21:25	90,10
21:21:30	90,10
21:21:35	90,10
21:21:40	90,10
21:21:45	90,10
21:21:50	90,10
21:21:55	90,10
21:22:00	90,10
21:22:05	90,10
21:22:10	90,10
21:22:15	90,10
21:22:20	90,10
21:22:25	90,10
21:22:30	90,10
21:22:35	90,10
21:22:40	90,10
21:22:45	90,10
21:22:50	90,10
21:22:55	90,10
21:23:00	90,10
21:23:05	90,10

21:23:10	90,10
21:23:15	90,10
21:23:20	90,10
21:23:25	90,10
21:23:30	90,10
21:23:35	90,10
21:23:40	90,10
21:23:45	90,10
21:23:50	90,10
21:23:55	90,10
21:24:00	90,10
21:24:05	90,10
21:24:10	90,10
21:24:15	90,10
21:24:20	90,10
21:24:25	90,10
21:24:30	90,10
21:24:35	90,10
21:24:40	90,10
21:24:45	90,10
21:24:50	90,10
21:24:55	90,10
21:25:00	90,10
21:25:05	90,10
21:25:10	90,10
21:25:15	90,10
21:25:20	90,10
21:25:25	90,10
21:25:30	90,10
21:25:35	90,10
21:25:40	90,10
21:25:45	90,10
21:25:50	90,10
21:25:55	90,10
21:26:00	90,10
21:26:05	90,10
21:26:10	90,10
21:26:15	90,10
21:26:20	90,10
21:26:25	90,10
21:26:30	90,10
21:26:35	90,10
21:26:40	90,10
21:26:45	90,10
21:26:50	90,10
21:26:55	90,20
21:27:00	90,20
21:27:05	90,20
21:27:10	90,20
21:27:15	90,20
21:27:20	90,20
21:27:25	90,20
21:27:30	90,10
21:27:35	90,10
21:27:40	90,10
21:27:45	90,10
21:27:50	90,10
21:27:55	90,10
21:28:00	90,10
21:28:05	90,10
21:28:10	90,10
21:28:15	90,10
21:28:20	90,10
21:28:25	90,20
21:28:30	90,20
21:28:35	90,20
21:28:40	90,20
21:28:45	90,20
21:28:50	90,20
21:28:55	90,10
21:29:00	90,10
21:29:05	90,10
21:29:10	90,10
21:29:15	90,10
21:29:20	90,10
21:29:25	90,10
21:29:30	90,10
21:29:35	90,10
21:29:40	90,10
21:29:45	90,10
21:29:50	90,10
21:29:55	90,10
21:30:00	90,10
21:30:05	90,10
21:30:10	90,10
21:30:15	90,10
21:30:20	90,10
21:30:25	90,10
21:30:30	90,10
21:30:35	90,10
21:30:40	90,10
21:30:45	90,10
21:30:50	90,10
21:30:55	90,10
21:31:00	90,10
21:31:05	90,10
21:31:10	90,10
21:31:15	90,10

21:31:20	90,10
21:31:25	90,10
21:31:30	90,10
21:31:35	90,10
21:31:40	90,10
21:31:45	90,10
21:31:50	90,10
21:31:55	90,10
21:32:00	90,10
21:32:05	90,10
21:32:10	90,10
21:32:15	90,10
21:32:20	90,10
21:32:25	90,10
21:32:30	90,10
21:32:35	90,10
21:32:40	90,10
21:32:45	90,10
21:32:50	90,10
21:32:55	90,10
21:33:00	90,10
21:33:05	90,10
21:33:10	90,10
21:33:15	90,10
21:33:20	90,10
21:33:25	90,10
21:33:30	90,10
21:33:35	90,10
21:33:40	90,10
21:33:45	90,00
21:33:50	90,00
21:33:55	90,00
21:34:00	90,00
21:34:05	90,00
21:34:10	90,00
21:34:15	90,00
21:34:20	90,00
21:34:25	90,10
21:34:30	90,10
21:34:35	90,10
21:34:40	90,10
21:34:45	90,10
21:34:50	90,10
21:34:55	90,10
21:35:00	90,10
21:35:05	90,10
21:35:10	90,10
21:35:15	90,10
21:35:20	90,10
21:35:25	90,00
21:35:30	90,00
21:35:35	90,10
21:35:40	90,10
21:35:45	90,10
21:35:50	90,10
21:35:55	90,10
21:36:00	90,10
21:36:05	90,10
21:36:10	90,10
21:36:15	90,10
21:36:20	90,10
21:36:25	90,10
21:36:30	90,10
21:36:35	90,10
21:36:40	90,10
21:36:45	90,10
21:36:50	90,10
21:36:55	90,10
21:37:00	90,10
21:37:05	90,10
21:37:10	90,10
21:37:15	90,10
21:37:20	90,10
21:37:25	90,10
21:37:30	90,10
21:37:35	90,10
21:37:40	90,10
21:37:45	90,10
21:37:50	90,10
21:37:55	90,10
21:38:00	90,10
21:38:05	90,10
21:38:10	90,10
21:38:15	90,10
21:38:20	90,10
21:38:25	90,10
21:38:30	90,10
21:38:35	90,10
21:38:40	90,10
21:38:45	90,10
21:38:50	90,10
21:38:55	90,10
21:39:00	90,10
21:39:05	90,10
21:39:10	90,10
21:39:15	90,10
21:39:20	90,10
21:39:25	90,10

21:39:30	90,10
21:39:35	90,10
21:39:40	90,10
21:39:45	90,10
21:39:50	90,10
21:39:55	90,10
21:40:00	90,10
21:40:05	90,10
21:40:10	90,10
21:40:15	90,10
21:40:20	90,10
21:40:25	90,10
21:40:30	90,10
21:40:35	90,10
21:40:40	90,10
21:40:45	90,10
21:40:50	90,10
21:40:55	90,10
21:41:00	90,20
21:41:05	90,20
21:41:10	90,20
21:41:15	90,20
21:41:20	90,20
21:41:25	90,20
21:41:30	90,20
21:41:35	90,20
21:41:40	90,20
21:41:45	90,20
21:41:50	90,20
21:41:55	90,20
21:42:00	90,20
21:42:05	90,20
21:42:10	90,20
21:42:15	90,20
21:42:20	90,20
21:42:25	90,20
21:42:30	90,20
21:42:35	90,30
21:42:40	90,30
21:42:45	90,30
21:42:50	90,30
21:42:55	90,30
21:43:00	90,30
21:43:05	90,30
21:43:10	90,30
21:43:15	90,30
21:43:20	90,30
21:43:25	90,30
21:43:30	90,30
21:43:35	90,30
21:43:40	90,30
21:43:45	90,40
21:43:50	90,40
21:43:55	90,30
21:44:00	90,30
21:44:05	90,30
21:44:10	90,30
21:44:15	90,30
21:44:20	90,30
21:44:25	90,30
21:44:30	90,30
21:44:35	90,40
21:44:40	90,40
21:44:45	90,40
21:44:50	90,40
21:44:55	90,40
21:45:00	90,30
21:45:05	90,30
21:45:10	90,30
21:45:15	90,30
21:45:20	90,30
21:45:25	90,30
21:45:30	90,30
21:45:35	90,20
21:45:40	90,20
21:45:45	90,30
21:45:50	90,30
21:45:55	90,20
21:46:00	90,20
21:46:05	90,20
21:46:10	90,20
21:46:15	90,20
21:46:20	90,20
21:46:25	90,20
21:46:30	90,20
21:46:35	90,20
21:46:40	90,20
21:46:45	90,20
21:46:50	90,20
21:46:55	90,20
21:47:00	90,10
21:47:05	90,10
21:47:10	90,10
21:47:15	90,10
21:47:20	90,10
21:47:25	90,10
21:47:30	90,10
21:47:35	90,10

21:47:40	90,10
21:47:45	90,10
21:47:50	90,10
21:47:55	90,00
21:48:00	90,00
21:48:05	90,00
21:48:10	90,00
21:48:15	90,00
21:48:20	90,00
21:48:25	90,00
21:48:30	90,00
21:48:35	90,00
21:48:40	90,00
21:48:45	89,90
21:48:50	89,90
21:48:55	89,90
21:49:00	89,90
21:49:05	89,90
21:49:10	89,90
21:49:15	89,90
21:49:20	89,90
21:49:25	89,90
21:49:30	89,90
21:49:35	89,90
21:49:40	89,80
21:49:45	89,80
21:49:50	89,80
21:49:55	89,80
21:50:00	89,80
21:50:05	89,80
21:50:10	89,80
21:50:15	89,80
21:50:20	89,80
21:50:25	89,80
21:50:30	89,80
21:50:35	89,80
21:50:40	89,80
21:50:45	89,80
21:50:50	89,80
21:50:55	89,80
21:51:00	89,80
21:51:05	89,80
21:51:10	89,80
21:51:15	89,80
21:51:20	89,80
21:51:25	89,80
21:51:30	89,80
21:51:35	89,80
21:51:40	89,80
21:51:45	89,80
21:51:50	89,80
21:51:55	89,80
21:52:00	89,80
21:52:05	89,80
21:52:10	89,80
21:52:15	89,80
21:52:20	89,80
21:52:25	89,80
21:52:30	89,80
21:52:35	89,80
21:52:40	89,80
21:52:45	89,80
21:52:50	89,80
21:52:55	89,80
21:53:00	89,80
21:53:05	89,80
21:53:10	89,80
21:53:15	89,80
21:53:20	89,80
21:53:25	89,80
21:53:30	89,80
21:53:35	89,80
21:53:40	89,80
21:53:45	89,80
21:53:50	89,80
21:53:55	89,80
21:54:00	89,80
21:54:05	89,80
21:54:10	89,80
21:54:15	89,80
21:54:20	89,80
21:54:25	89,80
21:54:30	89,80
21:54:35	89,80
21:54:40	89,80
21:54:45	89,80
21:54:50	89,80
21:54:55	89,80
21:55:00	89,80
21:55:05	89,80
21:55:10	89,80
21:55:15	89,80
21:55:20	89,90
21:55:25	89,90
21:55:30	89,90
21:55:35	89,90
21:55:40	89,90
21:55:45	89,90

21:55:50	89,90
21:55:55	89,90
21:56:00	90,00
21:56:05	89,90
21:56:10	89,90
21:56:15	89,90
21:56:20	89,90
21:56:25	89,90
21:56:30	89,90
21:56:35	89,90
21:56:40	89,90
21:56:45	89,90
21:56:50	89,90
21:56:55	89,90
21:57:00	89,90
21:57:05	89,90
21:57:10	89,90
21:57:15	89,90
21:57:20	89,90
21:57:25	89,90
21:57:30	89,90
21:57:35	89,90
21:57:40	89,90
21:57:45	89,90
21:57:50	89,90
21:57:55	89,90
21:58:00	90,00
21:58:05	90,00
21:58:10	90,00
21:58:15	90,00
21:58:20	90,00
21:58:25	90,00
21:58:30	90,00
21:58:35	90,00
21:58:40	90,00
21:58:45	90,00
21:58:50	90,00
21:58:55	90,00
21:59:00	90,00
21:59:05	90,00
21:59:10	89,90
21:59:15	89,90
21:59:20	89,90
21:59:25	89,90
21:59:30	89,90
21:59:35	89,90
21:59:40	89,90
21:59:45	89,90
21:59:50	89,90
21:59:55	89,90
22:00:00	89,90
22:00:05	89,90
22:00:10	89,90
22:00:15	89,90
22:00:20	90,00
22:00:25	90,00
22:00:30	90,00
22:00:35	90,00
22:00:40	89,90
22:00:45	89,90
22:00:50	89,90
22:00:55	90,00
22:01:00	90,00
22:01:05	89,90
22:01:10	89,90
22:01:15	89,90
22:01:20	89,90
22:01:25	90,00
22:01:30	89,90
22:01:35	89,90
22:01:40	89,90
22:01:45	89,90
22:01:50	90,00
22:01:55	90,00
22:02:00	90,00
22:02:05	90,00
22:02:10	90,00
22:02:15	90,00
22:02:20	90,00
22:02:25	90,00
22:02:30	90,00
22:02:35	90,00
22:02:40	90,00
22:02:45	90,00
22:02:50	90,00
22:02:55	90,00
22:03:00	90,00
22:03:05	90,00
22:03:10	90,00
22:03:15	90,00
22:03:20	90,00
22:03:25	89,90
22:03:30	90,00
22:03:35	90,00
22:03:40	90,00
22:03:45	90,00
22:03:50	90,00
22:03:55	90,00

22:04:00	90,00
22:04:05	90,00
22:04:10	90,00
22:04:15	90,00
22:04:20	90,00
22:04:25	90,10
22:04:30	90,10
22:04:35	90,10
22:04:40	90,10
22:04:45	90,10
22:04:50	90,10
22:04:55	90,10
22:05:00	90,10
22:05:05	90,10
22:05:10	90,10
22:05:15	90,10
22:05:20	90,10
22:05:25	90,10
22:05:30	90,10
22:05:35	90,10
22:05:40	90,10
22:05:45	90,10
22:05:50	90,10
22:05:55	90,10
22:06:00	90,10
22:06:05	90,10
22:06:10	90,10
22:06:15	90,10
22:06:20	90,10
22:06:25	90,10
22:06:30	90,10
22:06:35	90,10
22:06:40	90,10
22:06:45	90,10
22:06:50	90,10
22:06:55	90,10
22:07:00	90,20
22:07:05	90,10
22:07:10	90,10
22:07:15	90,10
22:07:20	90,10
22:07:25	90,20
22:07:30	90,20
22:07:35	90,20
22:07:40	90,20
22:07:45	90,20
22:07:50	90,20
22:07:55	90,20
22:08:00	90,20
22:08:05	90,20
22:08:10	90,20
22:08:15	90,20
22:08:20	90,20
22:08:25	90,20
22:08:30	90,20
22:08:35	90,20
22:08:40	90,20
22:08:45	90,20
22:08:50	90,20
22:08:55	90,20
22:09:00	90,20
22:09:05	90,20
22:09:10	90,20
22:09:15	90,30
22:09:20	90,30
22:09:25	90,30
22:09:30	90,30
22:09:35	90,20
22:09:40	90,20
22:09:45	90,20
22:09:50	90,20
22:09:55	90,20
22:10:00	90,20
22:10:05	90,20
22:10:10	90,20
22:10:15	90,20
22:10:20	90,20
22:10:25	90,20
22:10:30	90,20
22:10:35	90,20
22:10:40	90,20
22:10:45	90,20
22:10:50	90,20
22:10:55	90,20
22:11:00	90,20
22:11:05	90,10
22:11:10	90,10
22:11:15	90,10
22:11:20	90,10
22:11:25	90,10
22:11:30	90,10
22:11:35	90,10
22:11:40	90,10
22:11:45	90,10
22:11:50	90,10
22:11:55	90,10
22:12:00	90,10
22:12:05	90,10

22:12:10	90,10
22:12:15	90,10
22:12:20	90,10
22:12:25	90,10
22:12:30	90,10
22:12:35	90,10
22:12:40	90,10
22:12:45	90,10
22:12:50	90,10
22:12:55	90,10
22:13:00	90,10
22:13:05	90,10
22:13:10	90,00
22:13:15	90,00
22:13:20	90,00
22:13:25	90,00
22:13:30	90,00
22:13:35	90,00
22:13:40	90,00
22:13:45	90,00
22:13:50	90,00
22:13:55	90,00
22:14:00	90,00
22:14:05	90,00
22:14:10	90,00
22:14:15	90,00
22:14:20	90,00
22:14:25	90,00
22:14:30	90,00
22:14:35	90,00
22:14:40	90,00
22:14:45	89,90
22:14:50	89,90
22:14:55	89,90
22:15:00	89,90
22:15:05	89,90
22:15:10	89,90
22:15:15	89,90
22:15:20	89,90
22:15:25	89,90
22:15:30	89,90
22:15:35	89,90
22:15:40	89,90
22:15:45	89,90
22:15:50	89,90
22:15:55	89,80
22:16:00	89,80
22:16:05	89,80
22:16:10	89,80
22:16:15	89,80
22:16:20	89,80
22:16:25	89,80
22:16:30	89,80
22:16:35	89,80
22:16:40	89,80
22:16:45	89,80
22:16:50	89,80
22:16:55	89,80
22:17:00	89,80
22:17:05	89,80
22:17:10	89,80
22:17:15	89,80
22:17:20	89,80
22:17:25	89,80
22:17:30	89,80
22:17:35	89,80
22:17:40	89,80
22:17:45	89,80
22:17:50	89,80
22:17:55	89,80
22:18:00	89,80
22:18:05	89,80
22:18:10	89,80
22:18:15	89,80
22:18:20	89,80
22:18:25	89,80
22:18:30	89,80
22:18:35	89,80
22:18:40	89,80
22:18:45	89,70
22:18:50	89,70
22:18:55	89,70
22:19:00	89,70
22:19:05	89,70
22:19:10	89,70
22:19:15	89,70
22:19:20	89,70
22:19:25	89,70
22:19:30	89,70
22:19:35	89,70
22:19:40	89,70
22:19:45	89,70
22:19:50	89,70
22:19:55	89,70
22:20:00	89,70
22:20:05	89,70
22:20:10	89,70
22:20:15	89,70

22:20:20	89,70
22:20:25	89,70
22:20:30	89,70
22:20:35	89,70
22:20:40	89,70
22:20:45	89,70
22:20:50	89,70
22:20:55	89,70
22:21:00	89,70
22:21:05	89,70
22:21:10	89,70
22:21:15	89,70
22:21:20	89,70
22:21:25	89,70
22:21:30	89,70
22:21:35	89,70
22:21:40	89,70
22:21:45	89,70
22:21:50	89,70
22:21:55	89,70
22:22:00	89,70
22:22:05	89,70
22:22:10	89,70
22:22:15	89,70
22:22:20	89,70
22:22:25	89,70
22:22:30	89,70
22:22:35	89,70
22:22:40	89,80
22:22:45	89,80
22:22:50	89,80
22:22:55	89,80
22:23:00	89,80
22:23:05	89,70
22:23:10	89,70
22:23:15	89,70
22:23:20	89,70
22:23:25	89,70
22:23:30	89,70
22:23:35	89,80
22:23:40	89,80
22:23:45	89,80
22:23:50	89,80
22:23:55	89,80
22:24:00	89,80
22:24:05	89,80
22:24:10	89,80
22:24:15	89,80
22:24:20	89,80
22:24:25	89,80
22:24:30	89,80
22:24:35	89,80
22:24:40	89,80
22:24:45	89,80
22:24:50	89,80
22:24:55	89,80
22:25:00	89,80
22:25:05	89,80
22:25:10	89,80
22:25:15	89,80
22:25:20	89,80
22:25:25	89,80
22:25:30	89,80
22:25:35	89,80
22:25:40	89,80
22:25:45	89,80
22:25:50	89,80
22:25:55	89,80
22:26:00	89,80
22:26:05	89,80
22:26:10	89,80
22:26:15	89,80
22:26:20	89,80
22:26:25	89,80
22:26:30	89,80
22:26:35	89,80
22:26:40	89,80
22:26:45	89,80
22:26:50	89,80
22:26:55	89,80
22:27:00	89,80
22:27:05	89,80
22:27:10	89,80
22:27:15	89,80
22:27:20	89,80
22:27:25	89,80
22:27:30	89,80
22:27:35	89,80
22:27:40	89,80
22:27:45	89,80
22:27:50	89,80
22:27:55	89,80
22:28:00	89,80
22:28:05	89,80
22:28:10	89,80
22:28:15	89,80
22:28:20	89,80
22:28:25	89,80

22:28:30	89,80
22:28:35	89,80
22:28:40	89,80
22:28:45	89,80
22:28:50	89,80
22:28:55	89,80
22:29:00	89,80
22:29:05	89,80
22:29:10	89,80
22:29:15	89,80
22:29:20	89,80
22:29:25	89,80
22:29:30	89,80
22:29:35	89,80
22:29:40	89,80
22:29:45	89,80
22:29:50	89,80
22:29:55	89,80
22:30:00	89,80
22:30:05	89,80
22:30:10	89,80
22:30:15	89,80
22:30:20	89,80
22:30:25	89,80
22:30:30	89,80
22:30:35	89,80
22:30:40	89,80
22:30:45	89,80
22:30:50	89,80
22:30:55	89,80
22:31:00	89,70
22:31:05	89,80
22:31:10	89,80
22:31:15	89,80
22:31:20	89,80
22:31:25	89,80
22:31:30	89,80
22:31:35	89,80
22:31:40	89,80
22:31:45	89,80
22:31:50	89,80
22:31:55	89,80
22:32:00	89,80
22:32:05	89,80
22:32:10	89,80
22:32:15	89,80
22:32:20	89,80
22:32:25	89,80
22:32:30	89,80
22:32:35	89,80
22:32:40	89,80
22:32:45	89,80
22:32:50	89,80
22:32:55	89,80
22:33:00	89,80
22:33:05	89,80
22:33:10	89,80
22:33:15	89,80
22:33:20	89,80
22:33:25	89,80
22:33:30	89,80
22:33:35	89,80
22:33:40	89,80
22:33:45	89,80
22:33:50	89,80
22:33:55	89,80
22:34:00	89,80
22:34:05	89,80
22:34:10	89,80
22:34:15	89,80
22:34:20	89,80
22:34:25	89,80
22:34:30	89,80
22:34:35	89,80
22:34:40	89,80
22:34:45	89,80
22:34:50	89,80
22:34:55	89,80
22:35:00	89,80
22:35:05	89,80
22:35:10	89,80
22:35:15	89,80
22:35:20	89,80
22:35:25	89,70
22:35:30	89,70
22:35:35	89,70
22:35:40	89,70
22:35:45	89,70
22:35:50	89,70
22:35:55	89,70
22:36:00	89,70
22:36:05	89,70
22:36:10	89,70
22:36:15	89,70
22:36:20	89,70
22:36:25	89,70
22:36:30	89,70
22:36:35	89,70

22:36:40	89,70
22:36:45	89,70
22:36:50	89,70
22:36:55	89,70
22:37:00	89,70
22:37:05	89,70
22:37:10	89,70
22:37:15	89,70
22:37:20	89,70
22:37:25	89,70
22:37:30	89,70
22:37:35	89,60
22:37:40	89,60
22:37:45	89,60
22:37:50	89,60
22:37:55	89,60
22:38:00	89,60
22:38:05	89,60
22:38:10	89,60
22:38:15	89,60
22:38:20	89,60
22:38:25	89,60
22:38:30	89,60
22:38:35	89,60
22:38:40	89,60
22:38:45	89,60
22:38:50	89,60
22:38:55	89,60
22:39:00	89,60
22:39:05	89,60
22:39:10	89,60
22:39:15	89,60
22:39:20	89,60
22:39:25	89,60
22:39:30	89,60
22:39:35	89,60
22:39:40	89,60
22:39:45	89,60
22:39:50	89,60
22:39:55	89,60
22:40:00	89,60
22:40:05	89,60
22:40:10	89,60
22:40:15	89,60
22:40:20	89,60
22:40:25	89,60
22:40:30	89,70
22:40:35	89,70
22:40:40	89,60
22:40:45	89,70
22:40:50	89,70
22:40:55	89,70
22:41:00	89,70
22:41:05	89,70
22:41:10	89,70
22:41:15	89,70
22:41:20	89,70
22:41:25	89,70
22:41:30	89,70
22:41:35	89,70
22:41:40	89,70
22:41:45	89,70
22:41:50	89,60
22:41:55	89,60
22:42:00	89,60
22:42:05	89,60
22:42:10	89,70
22:42:15	89,70
22:42:20	89,60
22:42:25	89,60
22:42:30	89,70
22:42:35	89,70
22:42:40	89,70
22:42:45	89,70
22:42:50	89,70
22:42:55	89,70
22:43:00	89,70
22:43:05	89,70
22:43:10	89,70
22:43:15	89,70
22:43:20	89,70
22:43:25	89,70
22:43:30	89,70
22:43:35	89,70
22:43:40	89,70
22:43:45	89,70
22:43:50	89,70
22:43:55	89,70
22:44:00	89,70
22:44:05	89,70
22:44:10	89,70
22:44:15	89,70
22:44:20	89,70
22:44:25	89,70
22:44:30	89,60
22:44:35	89,60
22:44:40	89,60
22:44:45	89,60

22:44:50	89,60
22:44:55	89,60
22:45:00	89,60
22:45:05	89,60
22:45:10	89,60
22:45:15	89,60
22:45:20	89,60
22:45:25	89,60
22:45:30	89,60
22:45:35	89,60
22:45:40	89,60
22:45:45	89,60
22:45:50	89,60
22:45:55	89,60
22:46:00	89,60
22:46:05	89,60
22:46:10	89,60
22:46:15	89,60
22:46:20	89,60
22:46:25	89,60
22:46:30	89,60
22:46:35	89,60
22:46:40	89,60
22:46:45	89,60
22:46:50	89,70
22:46:55	89,70
22:47:00	89,70
22:47:05	89,70
22:47:10	89,70
22:47:15	89,70
22:47:20	89,70
22:47:25	89,70
22:47:30	89,70
22:47:35	89,70
22:47:40	89,70
22:47:45	89,70
22:47:50	89,70
22:47:55	89,70
22:48:00	89,70
22:48:05	89,70
22:48:10	89,70
22:48:15	89,60
22:48:20	89,60
22:48:25	89,60
22:48:30	89,60
22:48:35	89,60
22:48:40	89,60
22:48:45	89,60
22:48:50	89,60
22:48:55	89,60
22:49:00	89,60
22:49:05	89,50
22:49:10	89,50
22:49:15	89,50
22:49:20	89,50
22:49:25	89,50
22:49:30	89,50
22:49:35	89,50
22:49:40	89,50
22:49:45	89,50
22:49:50	89,50
22:49:55	89,50
22:50:00	89,50
22:50:05	89,50
22:50:10	89,50
22:50:15	89,60
22:50:20	89,60
22:50:25	89,60
22:50:30	89,60
22:50:35	89,50
22:50:40	89,50
22:50:45	89,50
22:50:50	89,50
22:50:55	89,50
22:51:00	89,50
22:51:05	89,50
22:51:10	89,50
22:51:15	89,50
22:51:20	89,50
22:51:25	89,60
22:51:30	89,60
22:51:35	89,60
22:51:40	89,60
22:51:45	89,70
22:51:50	89,70
22:51:55	89,70
22:52:00	89,70
22:52:05	89,70
22:52:10	89,70
22:52:15	89,70
22:52:20	89,60
22:52:25	89,60
22:52:30	89,60
22:52:35	89,60
22:52:40	89,60
22:52:45	89,60
22:52:50	89,60
22:52:55	89,60

22:53:00	89,50
22:53:05	89,50
22:53:10	89,50
22:53:15	89,50
22:53:20	89,50
22:53:25	89,50
22:53:30	89,50
22:53:35	89,50
22:53:40	89,60
22:53:45	89,60
22:53:50	89,60
22:53:55	89,60
22:54:00	89,60
22:54:05	89,60
22:54:10	89,60
22:54:15	89,60
22:54:20	89,60
22:54:25	89,60
22:54:30	89,60
22:54:35	89,70
22:54:40	89,60
22:54:45	89,60
22:54:50	89,70
22:54:55	89,70
22:55:00	89,70
22:55:05	89,70
22:55:10	89,70
22:55:15	89,70
22:55:20	89,70
22:55:25	89,70
22:55:30	89,70
22:55:35	89,70
22:55:40	89,70
22:55:45	89,70
22:55:50	89,70
22:55:55	89,70
22:56:00	89,70
22:56:05	89,80
22:56:10	89,80
22:56:15	89,80
22:56:20	89,80
22:56:25	89,80
22:56:30	89,90
22:56:35	89,90
22:56:40	89,90
22:56:45	90,00
22:56:50	90,00
22:56:55	90,00
22:57:00	90,00
22:57:05	90,00
22:57:10	90,00
22:57:15	90,00
22:57:20	90,00
22:57:25	90,10
22:57:30	90,10
22:57:35	90,10
22:57:40	90,10
22:57:45	90,10
22:57:50	90,10
22:57:55	90,10
22:58:00	90,10
22:58:05	90,10
22:58:10	90,20
22:58:15	90,20
22:58:20	90,20
22:58:25	90,20
22:58:30	90,20
22:58:35	90,20
22:58:40	90,20
22:58:45	90,20
22:58:50	90,20
22:58:55	90,20
22:59:00	90,20
22:59:05	90,20
22:59:10	90,20
22:59:15	90,20
22:59:20	90,20
22:59:25	90,20
22:59:30	90,20
22:59:35	90,20
22:59:40	90,20
22:59:45	90,10
22:59:50	90,10
22:59:55	90,10
23:00:00	90,10
23:00:05	90,10
23:00:10	90,20
23:00:15	90,20
23:00:20	90,20
23:00:25	90,20
23:00:30	90,20
23:00:35	90,20
23:00:40	90,20
23:00:45	90,20
23:00:50	90,20
23:00:55	90,20
23:01:00	90,20
23:01:05	90,20

23:01:10	90,20
23:01:15	90,20
23:01:20	90,20
23:01:25	90,10
23:01:30	90,10
23:01:35	90,10
23:01:40	90,10
23:01:45	90,10
23:01:50	90,10
23:01:55	90,10
23:02:00	90,10
23:02:05	90,10
23:02:10	90,10
23:02:15	90,00
23:02:20	90,00
23:02:25	90,00
23:02:30	90,00
23:02:35	90,00
23:02:40	90,00
23:02:45	89,90
23:02:50	89,90
23:02:55	89,90
23:03:00	89,90
23:03:05	89,90
23:03:10	89,90
23:03:15	89,90
23:03:20	89,90
23:03:25	89,90
23:03:30	89,90
23:03:35	89,90
23:03:40	89,90
23:03:45	89,90
23:03:50	89,90
23:03:55	89,90
23:04:00	89,80
23:04:05	89,80
23:04:10	89,80
23:04:15	89,80
23:04:20	89,80
23:04:25	89,80
23:04:30	89,80
23:04:35	89,70
23:04:40	89,70
23:04:45	89,70
23:04:50	89,70
23:04:55	89,70
23:05:00	89,70
23:05:05	89,70
23:05:10	89,70
23:05:15	89,60
23:05:20	89,60
23:05:25	89,60
23:05:30	89,60
23:05:35	89,60
23:05:40	89,60
23:05:45	89,60
23:05:50	89,60
23:05:55	89,60
23:06:00	89,60
23:06:05	89,60
23:06:10	89,60
23:06:15	89,60
23:06:20	89,60
23:06:25	89,70
23:06:30	89,70
23:06:35	89,60
23:06:40	89,60
23:06:45	89,60
23:06:50	89,60
23:06:55	89,60
23:07:00	89,60
23:07:05	89,60
23:07:10	89,60
23:07:15	89,60
23:07:20	89,60
23:07:25	89,60
23:07:30	89,60
23:07:35	89,60
23:07:40	89,60
23:07:45	89,60
23:07:50	89,60
23:07:55	89,60
23:08:00	89,60
23:08:05	89,60
23:08:10	89,60
23:08:15	89,70
23:08:20	89,70
23:08:25	89,70
23:08:30	89,70
23:08:35	89,70
23:08:40	89,70
23:08:45	89,70
23:08:50	89,70
23:08:55	89,70
23:09:00	89,70
23:09:05	89,70
23:09:10	89,70
23:09:15	89,70

23:09:20	89,70
23:09:25	89,70
23:09:30	89,70
23:09:35	89,70
23:09:40	89,70
23:09:45	89,70
23:09:50	89,70
23:09:55	89,70
23:10:00	89,70
23:10:05	89,70
23:10:10	89,80
23:10:15	89,80
23:10:20	89,80
23:10:25	89,80
23:10:30	89,80
23:10:35	89,80
23:10:40	89,80
23:10:45	89,80
23:10:50	89,80
23:10:55	89,80
23:11:00	89,80
23:11:05	89,80
23:11:10	89,80
23:11:15	89,80
23:11:20	89,80
23:11:25	89,80
23:11:30	89,80
23:11:35	89,80
23:11:40	89,80
23:11:45	89,80
23:11:50	89,80
23:11:55	89,80
23:12:00	89,80
23:12:05	89,80
23:12:10	89,80
23:12:15	89,90
23:12:20	89,90
23:12:25	89,90
23:12:30	89,90
23:12:35	89,90
23:12:40	89,90
23:12:45	89,90
23:12:50	89,90
23:12:55	89,90
23:13:00	89,90
23:13:05	89,90
23:13:10	89,90
23:13:15	89,90
23:13:20	89,90
23:13:25	89,90
23:13:30	89,90
23:13:35	89,90
23:13:40	89,90
23:13:45	89,90
23:13:50	89,90
23:13:55	89,90
23:14:00	89,90
23:14:05	89,90
23:14:10	89,90
23:14:15	89,90
23:14:20	89,90
23:14:25	89,90
23:14:30	89,90
23:14:35	89,90
23:14:40	89,90
23:14:45	89,90
23:14:50	89,80
23:14:55	89,80
23:15:00	89,80
23:15:05	89,80
23:15:10	89,80
23:15:15	89,80
23:15:20	89,80
23:15:25	89,80
23:15:30	89,80
23:15:35	89,80
23:15:40	89,80
23:15:45	89,80
23:15:50	89,80
23:15:55	89,80
23:16:00	89,70
23:16:05	89,70
23:16:10	89,70
23:16:15	89,70
23:16:20	89,70
23:16:25	89,70
23:16:30	89,70
23:16:35	89,70
23:16:40	89,70
23:16:45	89,70
23:16:50	89,70
23:16:55	89,70
23:17:00	89,70
23:17:05	89,70
23:17:10	89,70
23:17:15	89,70
23:17:20	89,70
23:17:25	89,60

23:17:30	89,60
23:17:35	89,60
23:17:40	89,60
23:17:45	89,60
23:17:50	89,70
23:17:55	89,70
23:18:00	89,70
23:18:05	89,70
23:18:10	89,70
23:18:15	89,70
23:18:20	89,70
23:18:25	89,70
23:18:30	89,70
23:18:35	89,70
23:18:40	89,70
23:18:45	89,60
23:18:50	89,60
23:18:55	89,60
23:19:00	89,60
23:19:05	89,50
23:19:10	89,50
23:19:15	89,50
23:19:20	89,50
23:19:25	89,60
23:19:30	89,60
23:19:35	89,60
23:19:40	89,60
23:19:45	89,60
23:19:50	89,60
23:19:55	89,60
23:20:00	89,60
23:20:05	89,70
23:20:10	89,70
23:20:15	89,70
23:20:20	89,70
23:20:25	89,70
23:20:30	89,70
23:20:35	89,70
23:20:40	89,70
23:20:45	89,70
23:20:50	89,60
23:20:55	89,60
23:21:00	89,60
23:21:05	89,60
23:21:10	89,60
23:21:15	89,60
23:21:20	89,60
23:21:25	89,60
23:21:30	89,60
23:21:35	89,60
23:21:40	89,60
23:21:45	89,60
23:21:50	89,60
23:21:55	89,60
23:22:00	89,60
23:22:05	89,60
23:22:10	89,50
23:22:15	89,50
23:22:20	89,50
23:22:25	89,50
23:22:30	89,50
23:22:35	89,50
23:22:40	89,50
23:22:45	89,50
23:22:50	89,50
23:22:55	89,50
23:23:00	89,50
23:23:05	89,60
23:23:10	89,60
23:23:15	89,60
23:23:20	89,60
23:23:25	89,60
23:23:30	89,60
23:23:35	89,60
23:23:40	89,60
23:23:45	89,60
23:23:50	89,60
23:23:55	89,60
23:24:00	89,60
23:24:05	89,60
23:24:10	89,60
23:24:15	89,60
23:24:20	89,60
23:24:25	89,50
23:24:30	89,50
23:24:35	89,50
23:24:40	89,50
23:24:45	89,50
23:24:50	89,50
23:24:55	89,50
23:25:00	89,50
23:25:05	89,50
23:25:10	89,60
23:25:15	89,60
23:25:20	89,60
23:25:25	89,60
23:25:30	89,60
23:25:35	89,60

23:25:40	89,70
23:25:45	89,70
23:25:50	89,70
23:25:55	89,70
23:26:00	89,70
23:26:05	89,60
23:26:10	89,60
23:26:15	89,60
23:26:20	89,60
23:26:25	89,60
23:26:30	89,60
23:26:35	89,60
23:26:40	89,60
23:26:45	89,60
23:26:50	89,60
23:26:55	89,60
23:27:00	89,60
23:27:05	89,60
23:27:10	89,60
23:27:15	89,60
23:27:20	89,60
23:27:25	89,60
23:27:30	89,60
23:27:35	89,50
23:27:40	89,50
23:27:45	89,50
23:27:50	89,50
23:27:55	89,50
23:28:00	89,50
23:28:05	89,50
23:28:10	89,50
23:28:15	89,50
23:28:20	89,50
23:28:25	89,50
23:28:30	89,50
23:28:35	89,50
23:28:40	89,50
23:28:45	89,50
23:28:50	89,50
23:28:55	89,50
23:29:00	89,60
23:29:05	89,60
23:29:10	89,60
23:29:15	89,60
23:29:20	89,60
23:29:25	89,60
23:29:30	89,70
23:29:35	89,70
23:29:40	89,70
23:29:45	89,80
23:29:50	89,80
23:29:55	89,80
23:30:00	89,80
23:30:05	89,80
23:30:10	89,80
23:30:15	89,80
23:30:20	89,80
23:30:25	89,80
23:30:30	89,80
23:30:35	89,80
23:30:40	89,90
23:30:45	89,90
23:30:50	89,90
23:30:55	89,90
23:31:00	89,90
23:31:05	89,90
23:31:10	89,90
23:31:15	89,90
23:31:20	89,90
23:31:25	89,90
23:31:30	89,90
23:31:35	89,90
23:31:40	89,90
23:31:45	90,00
23:31:50	90,00
23:31:55	90,00
23:32:00	90,00
23:32:05	90,00
23:32:10	90,00
23:32:15	90,00
23:32:20	90,00
23:32:25	90,00
23:32:30	90,00
23:32:35	90,00
23:32:40	90,10
23:32:45	90,00
23:32:50	90,10
23:32:55	90,10
23:33:00	90,10
23:33:05	90,10
23:33:10	90,10
23:33:15	90,20
23:33:20	90,20
23:33:25	90,20
23:33:30	90,20
23:33:35	90,20
23:33:40	90,20
23:33:45	90,20

23:33:50	90,20
23:33:55	90,20
23:34:00	90,10
23:34:05	90,10
23:34:10	90,10
23:34:15	90,10
23:34:20	90,10
23:34:25	90,10
23:34:30	90,10
23:34:35	90,20
23:34:40	90,20
23:34:45	90,20
23:34:50	90,20
23:34:55	90,20
23:35:00	90,20
23:35:05	90,20
23:35:10	90,20
23:35:15	90,20
23:35:20	90,20
23:35:25	90,20
23:35:30	90,20
23:35:35	90,20
23:35:40	90,20
23:35:45	90,20
23:35:50	90,20
23:35:55	90,20
23:36:00	90,20
23:36:05	90,20
23:36:10	90,20
23:36:15	90,20
23:36:20	90,20
23:36:25	90,20
23:36:30	90,20
23:36:35	90,20
23:36:40	90,20
23:36:45	90,20
23:36:50	90,20
23:36:55	90,20
23:37:00	90,20
23:37:05	90,20
23:37:10	90,20
23:37:15	90,20
23:37:20	90,20
23:37:25	90,10
23:37:30	90,10
23:37:35	90,20
23:37:40	90,20
23:37:45	90,20
23:37:50	90,20
23:37:55	90,20
23:38:00	90,20
23:38:05	90,20
23:38:10	90,20
23:38:15	90,20
23:38:20	90,20
23:38:25	90,20
23:38:30	90,20
23:38:35	90,20
23:38:40	90,20
23:38:45	90,20
23:38:50	90,30
23:38:55	90,30
23:39:00	90,30
23:39:05	90,30
23:39:10	90,30
23:39:15	90,30
23:39:20	90,30
23:39:25	90,30
23:39:30	90,20
23:39:35	90,20
23:39:40	90,20
23:39:45	90,20
23:39:50	90,20
23:39:55	90,20
23:40:00	90,20
23:40:05	90,20
23:40:10	90,20
23:40:15	90,20
23:40:20	90,20
23:40:25	90,20
23:40:30	90,20
23:40:35	90,20
23:40:40	90,20
23:40:45	90,20
23:40:50	90,20
23:40:55	90,20
23:41:00	90,20
23:41:05	90,20
23:41:10	90,20
23:41:15	90,20
23:41:20	90,20
23:41:25	90,20
23:41:30	90,20
23:41:35	90,20
23:41:40	90,20
23:41:45	90,20
23:41:50	90,20
23:41:55	90,20

23:42:00	90,20
23:42:05	90,20
23:42:10	90,20
23:42:15	90,20
23:42:20	90,20
23:42:25	90,20
23:42:30	90,20
23:42:35	90,10
23:42:40	90,10
23:42:45	90,10
23:42:50	90,10
23:42:55	90,10
23:43:00	90,10
23:43:05	90,10
23:43:10	90,10
23:43:15	90,10
23:43:20	90,10
23:43:25	90,10
23:43:30	90,10
23:43:35	90,10
23:43:40	90,10
23:43:45	90,10
23:43:50	90,10
23:43:55	90,10
23:44:00	90,10
23:44:05	90,10
23:44:10	90,10
23:44:15	90,10
23:44:20	90,10
23:44:25	90,10
23:44:30	90,10
23:44:35	90,10
23:44:40	90,10
23:44:45	90,10
23:44:50	90,10
23:44:55	90,10
23:45:00	90,10
23:45:05	90,10
23:45:10	90,00
23:45:15	90,10
23:45:20	90,10
23:45:25	90,00
23:45:30	90,00
23:45:35	90,00
23:45:40	90,10
23:45:45	90,10
23:45:50	90,10
23:45:55	90,10
23:46:00	90,10
23:46:05	90,00
23:46:10	90,00
23:46:15	90,00
23:46:20	90,00
23:46:25	90,00
23:46:30	90,10
23:46:35	90,10
23:46:40	90,10
23:46:45	90,10
23:46:50	90,10
23:46:55	90,10
23:47:00	90,10
23:47:05	90,10
23:47:10	90,10
23:47:15	90,10
23:47:20	90,10
23:47:25	90,10
23:47:30	90,10
23:47:35	90,10
23:47:40	90,10
23:47:45	90,10
23:47:50	90,10
23:47:55	90,10
23:48:00	90,00
23:48:05	90,00
23:48:10	90,00
23:48:15	90,00
23:48:20	89,90
23:48:25	89,90
23:48:30	90,00
23:48:35	89,90
23:48:40	89,90
23:48:45	89,90
23:48:50	90,00
23:48:55	90,00
23:49:00	90,00
23:49:05	90,00
23:49:10	90,00
23:49:15	90,00
23:49:20	90,00
23:49:25	90,00
23:49:30	90,00
23:49:35	90,00
23:49:40	90,00
23:49:45	90,00
23:49:50	90,00
23:49:55	90,00
23:50:00	90,00
23:50:05	90,00

23:50:10	89,90
23:50:15	89,90
23:50:20	89,90
23:50:25	89,90
23:50:30	89,90
23:50:35	89,90
23:50:40	89,90
23:50:45	89,90
23:50:50	89,90
23:50:55	89,90
23:51:00	89,90
23:51:05	89,90
23:51:10	89,90
23:51:15	89,90
23:51:20	89,90
23:51:25	89,90
23:51:30	89,90
23:51:35	89,90
23:51:40	89,80
23:51:45	89,80
23:51:50	89,90
23:51:55	89,90
23:52:00	89,90
23:52:05	89,90
23:52:10	89,90
23:52:15	89,90
23:52:20	89,90
23:52:25	89,90
23:52:30	89,90
23:52:35	89,90
23:52:40	89,90
23:52:45	89,90
23:52:50	89,90
23:52:55	90,00
23:53:00	90,00
23:53:05	90,00
23:53:10	90,00
23:53:15	90,00
23:53:20	90,00
23:53:25	90,00
23:53:30	90,00
23:53:35	90,00
23:53:40	90,00
23:53:45	90,00
23:53:50	90,00
23:53:55	89,90
23:54:00	89,90
23:54:05	89,90
23:54:10	89,90
23:54:15	89,90
23:54:20	89,90
23:54:25	89,90
23:54:30	89,90
23:54:35	89,90
23:54:40	89,90
23:54:45	89,90
23:54:50	89,90
23:54:55	89,90
23:55:00	89,90
23:55:05	89,90
23:55:10	89,90
23:55:15	89,90
23:55:20	89,90
23:55:25	89,90
23:55:30	89,90
23:55:35	89,90
23:55:40	89,90
23:55:45	89,90
23:55:50	89,90
23:55:55	90,00
23:56:00	90,00
23:56:05	90,00
23:56:10	89,90
23:56:15	89,90
23:56:20	89,90
23:56:25	89,90
23:56:30	89,90
23:56:35	89,90
23:56:40	89,90
23:56:45	89,90
23:56:50	89,90
23:56:55	89,90
23:57:00	89,90
23:57:05	89,90
23:57:10	89,90
23:57:15	90,00
23:57:20	90,00
23:57:25	90,00
23:57:30	90,10
23:57:35	90,10
23:57:40	90,10
23:57:45	90,10
23:57:50	90,10
23:57:55	90,10
23:58:00	90,10
23:58:05	90,10
23:58:10	90,10
23:58:15	90,10

23:58:20	90,10
23:58:25	90,10
23:58:30	90,10
23:58:35	90,10
23:58:40	90,10
23:58:45	90,10
23:58:50	90,10
23:58:55	90,10
23:59:00	90,10
23:59:05	90,00
23:59:10	90,00
23:59:15	90,00
23:59:20	90,00
23:59:25	89,90
23:59:30	89,90
23:59:35	89,90
23:59:40	89,90
23:59:45	89,90
23:59:50	89,90
23:59:55	89,90
00:00:00	89,90
00:00:05	89,90
00:00:10	89,90
00:00:15	89,90
00:00:20	89,90
00:00:25	89,90
00:00:30	89,90
00:00:35	89,90
00:00:40	89,90
00:00:45	89,90
00:00:50	89,90
00:00:55	89,90
00:01:00	89,90
00:01:05	89,80
00:01:10	89,80
00:01:15	89,80
00:01:20	89,80
00:01:25	89,80
00:01:30	89,70
00:01:35	89,70
00:01:40	89,70
00:01:45	89,70
00:01:50	89,70
00:01:55	89,70
00:02:00	89,60
00:02:05	89,60
00:02:10	89,60
00:02:15	89,60
00:02:20	89,60
00:02:25	89,60
00:02:30	89,60
00:02:35	89,60
00:02:40	89,60
00:02:45	89,60
00:02:50	89,60
00:02:55	89,60
00:03:00	89,60
00:03:05	89,60
00:03:10	89,60
00:03:15	89,60
00:03:20	89,60
00:03:25	89,60
00:03:30	89,60
00:03:35	89,60
00:03:40	89,60
00:03:45	89,50
00:03:50	89,50
00:03:55	89,50
00:04:00	89,50
00:04:05	89,50
00:04:10	89,50
00:04:15	89,50
00:04:20	89,50
00:04:25	89,60
00:04:30	89,60
00:04:35	89,60
00:04:40	89,60
00:04:45	89,60
00:04:50	89,60
00:04:55	89,60
00:05:00	89,60
00:05:05	89,60
00:05:10	89,60
00:05:15	89,60
00:05:20	89,60
00:05:25	89,60
00:05:30	89,60
00:05:35	89,60
00:05:40	89,60
00:05:45	89,60
00:05:50	89,60
00:05:55	89,60
00:06:00	89,70
00:06:05	89,60
00:06:10	89,60
00:06:15	89,70
00:06:20	89,60
00:06:25	89,60

00:06:30	89,60
00:06:35	89,60
00:06:40	89,60
00:06:45	89,60
00:06:50	89,60
00:06:55	89,60
00:07:00	89,60
00:07:05	89,60
00:07:10	89,60
00:07:15	89,60
00:07:20	89,70
00:07:25	89,70
00:07:30	89,70
00:07:35	89,70
00:07:40	89,70
00:07:45	89,70
00:07:50	89,70
00:07:55	89,70
00:08:00	89,70
00:08:05	89,70
00:08:10	89,70
00:08:15	89,70
00:08:20	89,70
00:08:25	89,70
00:08:30	89,70
00:08:35	89,70
00:08:40	89,70
00:08:45	89,70
00:08:50	89,70
00:08:55	89,70
00:09:00	89,70
00:09:05	89,60
00:09:10	89,60
00:09:15	89,60
00:09:20	89,60
00:09:25	89,60
00:09:30	89,60
00:09:35	89,60
00:09:40	89,60
00:09:45	89,70
00:09:50	89,70
00:09:55	89,70
00:10:00	89,70
00:10:05	89,70
00:10:10	89,70
00:10:15	89,70
00:10:20	89,70
00:10:25	89,70
00:10:30	89,70
00:10:35	89,70
00:10:40	89,70
00:10:45	89,70
00:10:50	89,70
00:10:55	89,70
00:11:00	89,70
00:11:05	89,70
00:11:10	89,70
00:11:15	89,70
00:11:20	89,70
00:11:25	89,80
00:11:30	89,70
00:11:35	89,80
00:11:40	89,70
00:11:45	89,70
00:11:50	89,70
00:11:55	89,70
00:12:00	89,70
00:12:05	89,70
00:12:10	89,70
00:12:15	89,70
00:12:20	89,70
00:12:25	89,70
00:12:30	89,70
00:12:35	89,80
00:12:40	89,80
00:12:45	89,80
00:12:50	89,80
00:12:55	89,80
00:13:00	89,80
00:13:05	89,80
00:13:10	89,80
00:13:15	89,80
00:13:20	89,80
00:13:25	89,80
00:13:30	89,80
00:13:35	89,80
00:13:40	89,80
00:13:45	89,80
00:13:50	89,80
00:13:55	89,80
00:14:00	89,80
00:14:05	89,80
00:14:10	89,80
00:14:15	89,80
00:14:20	89,80
00:14:25	89,80
00:14:30	89,80
00:14:35	89,80

00:14:40	89,80
00:14:45	89,80
00:14:50	89,80
00:14:55	89,80
00:15:00	89,80
00:15:05	89,80
00:15:10	89,90
00:15:15	89,90
00:15:20	89,90
00:15:25	89,90
00:15:30	89,90
00:15:35	89,90
00:15:40	89,90
00:15:45	89,90
00:15:50	89,90
00:15:55	89,90
00:16:00	89,90
00:16:05	89,90
00:16:10	89,90
00:16:15	89,90
00:16:20	89,90
00:16:25	89,90
00:16:30	89,90
00:16:35	89,90
00:16:40	89,90
00:16:45	89,90
00:16:50	89,90
00:16:55	89,90
00:17:00	89,90
00:17:05	89,90
00:17:10	89,90
00:17:15	89,90
00:17:20	90,00
00:17:25	89,90
00:17:30	89,90
00:17:35	90,00
00:17:40	90,00
00:17:45	90,00
00:17:50	90,00
00:17:55	90,00
00:18:00	90,00
00:18:05	90,00
00:18:10	90,00
00:18:15	90,00
00:18:20	90,00
00:18:25	90,00
00:18:30	90,00
00:18:35	90,00
00:18:40	90,00
00:18:45	89,90
00:18:50	89,90
00:18:55	89,90
00:19:00	89,90
00:19:05	89,90
00:19:10	90,00
00:19:15	90,00
00:19:20	90,00
00:19:25	89,90
00:19:30	89,90
00:19:35	89,90
00:19:40	89,90
00:19:45	89,90
00:19:50	89,90
00:19:55	89,90
00:20:00	89,90
00:20:05	89,90
00:20:10	89,90
00:20:15	89,90
00:20:20	89,90
00:20:25	89,90
00:20:30	89,90
00:20:35	89,90
00:20:40	89,90
00:20:45	89,90
00:20:50	89,80
00:20:55	89,90
00:21:00	89,80
00:21:05	89,80
00:21:10	89,80
00:21:15	89,80
00:21:20	89,80
00:21:25	89,80
00:21:30	89,80
00:21:35	89,80
00:21:40	89,80
00:21:45	89,80
00:21:50	89,80
00:21:55	89,80
00:22:00	89,80
00:22:05	89,80
00:22:10	89,80
00:22:15	89,80
00:22:20	89,80
00:22:25	89,80
00:22:30	89,80
00:22:35	89,80
00:22:40	89,80
00:22:45	89,70

00:22:50	89,70
00:22:55	89,70
00:23:00	89,70
00:23:05	89,70
00:23:10	89,70
00:23:15	89,70
00:23:20	89,70
00:23:25	89,70
00:23:30	89,70
00:23:35	89,70
00:23:40	89,70
00:23:45	89,70
00:23:50	89,80
00:23:55	89,80
00:24:00	89,80
00:24:05	89,80
00:24:10	89,80
00:24:15	89,80
00:24:20	89,80
00:24:25	89,80
00:24:30	89,80
00:24:35	89,80
00:24:40	89,80
00:24:45	89,80
00:24:50	89,80
00:24:55	89,80
00:25:00	89,80
00:25:05	89,90
00:25:10	89,90
00:25:15	89,90
00:25:20	89,90
00:25:25	89,90
00:25:30	89,90
00:25:35	89,90
00:25:40	89,90
00:25:45	89,90
00:25:50	89,90
00:25:55	89,90
00:26:00	89,90
00:26:05	89,80
00:26:10	89,90
00:26:15	89,90
00:26:20	89,80
00:26:25	89,90
00:26:30	89,90
00:26:35	89,90
00:26:40	89,90
00:26:45	89,90
00:26:50	89,90
00:26:55	89,90
00:27:00	89,90
00:27:05	89,90
00:27:10	89,90
00:27:15	89,90
00:27:20	89,90
00:27:25	89,90
00:27:30	89,90
00:27:35	89,90
00:27:40	89,90
00:27:45	89,90
00:27:50	89,90
00:27:55	89,90
00:28:00	89,90
00:28:05	89,90
00:28:10	89,90
00:28:15	89,90
00:28:20	89,90
00:28:25	89,90
00:28:30	89,90
00:28:35	89,90
00:28:40	90,00
00:28:45	90,00
00:28:50	90,00
00:28:55	90,00
00:29:00	90,00
00:29:05	90,00
00:29:10	90,00
00:29:15	90,00
00:29:20	90,00
00:29:25	90,00
00:29:30	90,00
00:29:35	90,00
00:29:40	90,00
00:29:45	90,10
00:29:50	90,00
00:29:55	90,10
00:30:00	90,10
00:30:05	90,00
00:30:10	90,00
00:30:15	90,00
00:30:20	90,00
00:30:25	90,00
00:30:30	90,00
00:30:35	90,10
00:30:40	90,10
00:30:45	90,10
00:30:50	90,10
00:30:55	90,10

00:31:00	90,10
00:31:05	90,10
00:31:10	90,10
00:31:15	90,10
00:31:20	90,10
00:31:25	90,10
00:31:30	90,10
00:31:35	90,10
00:31:40	90,10
00:31:45	90,10
00:31:50	90,10
00:31:55	90,10
00:32:00	90,10
00:32:05	90,10
00:32:10	90,10
00:32:15	90,10
00:32:20	90,10
00:32:25	90,20
00:32:30	90,20
00:32:35	90,20
00:32:40	90,20
00:32:45	90,20
00:32:50	90,20
00:32:55	90,20
00:33:00	90,20
00:33:05	90,20
00:33:10	90,20
00:33:15	90,20
00:33:20	90,20
00:33:25	90,20
00:33:30	90,20
00:33:35	90,20
00:33:40	90,20
00:33:45	90,20
00:33:50	90,20
00:33:55	90,20
00:34:00	90,20
00:34:05	90,20
00:34:10	90,20
00:34:15	90,20
00:34:20	90,20
00:34:25	90,20
00:34:30	90,20
00:34:35	90,20
00:34:40	90,20
00:34:45	90,20
00:34:50	90,20
00:34:55	90,20
00:35:00	90,20
00:35:05	90,20
00:35:10	90,20
00:35:15	90,20
00:35:20	90,20
00:35:25	90,20
00:35:30	90,20
00:35:35	90,20
00:35:40	90,20
00:35:45	90,20
00:35:50	90,20
00:35:55	90,20
00:36:00	90,20
00:36:05	90,20
00:36:10	90,20
00:36:15	90,20
00:36:20	90,20
00:36:25	90,20
00:36:30	90,20
00:36:35	90,20
00:36:40	90,20
00:36:45	90,20
00:36:50	90,20
00:36:55	90,20
00:37:00	90,20
00:37:05	90,20
00:37:10	90,20
00:37:15	90,20
00:37:20	90,20
00:37:25	90,20
00:37:30	90,20
00:37:35	90,20
00:37:40	90,20
00:37:45	90,20
00:37:50	90,20
00:37:55	90,20
00:38:00	90,20
00:38:05	90,20
00:38:10	90,20
00:38:15	90,20
00:38:20	90,20
00:38:25	90,20
00:38:30	90,20
00:38:35	90,20
00:38:40	90,20
00:38:45	90,20
00:38:50	90,20
00:38:55	90,20
00:39:00	90,20
00:39:05	90,20

00:39:10	90,20
00:39:15	90,20
00:39:20	90,20
00:39:25	90,20
00:39:30	90,20
00:39:35	90,20
00:39:40	90,20
00:39:45	90,30
00:39:50	90,30
00:39:55	90,20
00:40:00	90,20
00:40:05	90,20
00:40:10	90,20
00:40:15	90,20
00:40:20	90,20
00:40:25	90,20
00:40:30	90,20
00:40:35	90,20
00:40:40	90,20
00:40:45	90,10
00:40:50	90,10
00:40:55	90,10
00:41:00	90,10
00:41:05	90,10
00:41:10	90,10
00:41:15	90,10
00:41:20	90,10
00:41:25	90,10
00:41:30	90,10
00:41:35	90,10
00:41:40	90,10
00:41:45	90,10
00:41:50	90,10
00:41:55	90,10
00:42:00	90,10
00:42:05	90,00
00:42:10	90,00
00:42:15	90,00
00:42:20	90,00
00:42:25	90,00
00:42:30	90,00
00:42:35	90,00
00:42:40	90,00
00:42:45	90,00
00:42:50	90,00
00:42:55	90,00
00:43:00	90,00
00:43:05	90,00
00:43:10	90,00
00:43:15	90,00
00:43:20	90,00
00:43:25	90,00
00:43:30	89,90
00:43:35	89,90
00:43:40	89,90
00:43:45	89,90
00:43:50	89,90
00:43:55	89,90
00:44:00	89,90
00:44:05	89,90
00:44:10	89,90
00:44:15	89,90
00:44:20	89,90
00:44:25	89,90
00:44:30	89,90
00:44:35	89,90
00:44:40	89,90
00:44:45	89,80
00:44:50	89,80
00:44:55	89,80
00:45:00	89,80
00:45:05	89,80
00:45:10	89,80
00:45:15	89,80
00:45:20	89,80
00:45:25	89,80
00:45:30	89,80
00:45:35	89,80
00:45:40	89,80
00:45:45	89,80
00:45:50	89,80
00:45:55	89,80
00:46:00	89,80
00:46:05	89,80
00:46:10	89,80
00:46:15	89,80
00:46:20	89,80
00:46:25	89,80
00:46:30	89,80
00:46:35	89,80
00:46:40	89,80
00:46:45	89,80
00:46:50	89,80
00:46:55	89,80
00:47:00	89,80
00:47:05	89,70
00:47:10	89,70
00:47:15	89,70

00:47:20	89,70
00:47:25	89,70
00:47:30	89,70
00:47:35	89,70
00:47:40	89,70
00:47:45	89,70
00:47:50	89,70
00:47:55	89,70
00:48:00	89,70
00:48:05	89,70
00:48:10	89,80
00:48:15	89,80
00:48:20	89,80
00:48:25	89,80
00:48:30	89,80
00:48:35	89,80
00:48:40	89,80
00:48:45	89,80
00:48:50	89,90
00:48:55	89,90
00:49:00	89,90
00:49:05	89,90
00:49:10	89,90
00:49:15	89,90
00:49:20	89,90
00:49:25	89,90
00:49:30	89,90
00:49:35	89,90
00:49:40	89,90
00:49:45	89,90
00:49:50	89,90
00:49:55	89,90
00:50:00	89,90
00:50:05	89,90
00:50:10	89,90
00:50:15	89,90
00:50:20	89,90
00:50:25	89,90
00:50:30	89,90
00:50:35	90,00
00:50:40	90,00
00:50:45	90,00
00:50:50	90,00
00:50:55	90,00
00:51:00	90,00
00:51:05	90,00
00:51:10	90,00
00:51:15	90,00
00:51:20	90,00
00:51:25	90,00
00:51:30	90,10
00:51:35	90,10
00:51:40	90,10
00:51:45	90,10
00:51:50	90,10
00:51:55	90,10
00:52:00	90,10
00:52:05	90,10
00:52:10	90,10
00:52:15	90,10
00:52:20	90,10
00:52:25	90,10
00:52:30	90,10
00:52:35	90,10
00:52:40	90,10
00:52:45	90,10
00:52:50	90,10
00:52:55	90,10
00:53:00	90,10
00:53:05	90,10
00:53:10	90,10
00:53:15	90,10
00:53:20	90,10
00:53:25	90,10
00:53:30	90,10
00:53:35	90,10
00:53:40	90,10
00:53:45	90,10
00:53:50	90,10
00:53:55	90,10
00:54:00	90,10
00:54:05	90,20
00:54:10	90,20
00:54:15	90,20
00:54:20	90,20
00:54:25	90,20
00:54:30	90,20
00:54:35	90,20
00:54:40	90,20
00:54:45	90,20
00:54:50	90,20
00:54:55	90,20
00:55:00	90,20
00:55:05	90,20
00:55:10	90,20
00:55:15	90,20
00:55:20	90,20
00:55:25	90,10

00:55:30	90,20
00:55:35	90,20
00:55:40	90,20
00:55:45	90,20
00:55:50	90,20
00:55:55	90,20
00:56:00	90,20
00:56:05	90,20
00:56:10	90,20
00:56:15	90,20
00:56:20	90,20
00:56:25	90,20
00:56:30	90,20
00:56:35	90,20
00:56:40	90,20
00:56:45	90,20
00:56:50	90,20
00:56:55	90,20
00:57:00	90,20
00:57:05	90,20
00:57:10	90,20
00:57:15	90,20
00:57:20	90,20
00:57:25	90,20
00:57:30	90,20
00:57:35	90,10
00:57:40	90,10
00:57:45	90,10
00:57:50	90,10
00:57:55	90,10
00:58:00	90,10
00:58:05	90,20
00:58:10	90,20
00:58:15	90,20
00:58:20	90,20
00:58:25	90,20
00:58:30	90,10
00:58:35	90,10
00:58:40	90,20
00:58:45	90,10
00:58:50	90,10
00:58:55	90,10
00:59:00	90,10
00:59:05	90,10
00:59:10	90,10
00:59:15	90,10
00:59:20	90,10
00:59:25	90,10
00:59:30	90,10
00:59:35	90,10
00:59:40	90,10
00:59:45	90,10
00:59:50	90,10
00:59:55	90,10
01:00:00	90,10
01:00:05	90,10
01:00:10	90,10
01:00:15	90,10
01:00:20	90,10
01:00:25	90,10
01:00:30	90,10
01:00:35	90,10
01:00:40	90,10
01:00:45	90,10
01:00:50	90,10
01:00:55	90,10
01:01:00	90,10
01:01:05	90,10
01:01:10	90,10
01:01:15	90,10
01:01:20	90,10
01:01:25	90,10
01:01:30	90,10
01:01:35	90,10
01:01:40	90,10
01:01:45	90,10
01:01:50	90,10
01:01:55	90,10
01:02:00	90,10
01:02:05	90,10
01:02:10	90,10
01:02:15	90,10
01:02:20	90,10
01:02:25	90,10
01:02:30	90,10
01:02:35	90,10
01:02:40	90,10
01:02:45	90,10
01:02:50	90,10
01:02:55	90,10
01:03:00	90,10
01:03:05	90,10
01:03:10	90,10
01:03:15	90,10
01:03:20	90,10
01:03:25	90,10
01:03:30	90,10
01:03:35	90,10

01:03:40	90,10
01:03:45	90,00
01:03:50	90,00
01:03:55	90,00
01:04:00	90,00
01:04:05	90,00
01:04:10	90,00
01:04:15	90,00
01:04:20	90,00
01:04:25	90,00
01:04:30	90,00
01:04:35	90,00
01:04:40	90,00
01:04:45	90,00
01:04:50	90,00
01:04:55	90,00
01:05:00	90,00
01:05:05	90,00
01:05:10	89,90
01:05:15	89,90
01:05:20	89,90
01:05:25	89,90
01:05:30	89,90
01:05:35	89,90
01:05:40	89,90
01:05:45	89,90
01:05:50	89,90
01:05:55	89,90
01:06:00	89,90
01:06:05	89,90
01:06:10	89,90
01:06:15	89,90
01:06:20	89,90
01:06:25	89,90
01:06:30	89,90
01:06:35	89,90
01:06:40	89,90
01:06:45	89,90
01:06:50	89,90
01:06:55	89,90
01:07:00	89,90
01:07:05	89,90
01:07:10	89,80
01:07:15	89,80
01:07:20	89,80
01:07:25	89,80
01:07:30	89,80
01:07:35	89,80
01:07:40	89,80
01:07:45	89,80
01:07:50	89,80
01:07:55	89,80
01:08:00	89,80
01:08:05	89,80
01:08:10	89,80
01:08:15	89,80
01:08:20	89,80
01:08:25	89,80
01:08:30	89,80
01:08:35	89,90
01:08:40	89,90
01:08:45	89,90
01:08:50	89,90
01:08:55	89,90
01:09:00	89,90
01:09:05	89,90
01:09:10	89,90
01:09:15	89,90
01:09:20	89,90
01:09:25	89,90
01:09:30	89,90
01:09:35	89,90
01:09:40	89,90
01:09:45	89,90
01:09:50	89,90
01:09:55	89,90
01:10:00	89,90

POTENCIA TRAF0 LADO 66 KV - NAVE #1

Date/Time	kWh rec int	kW Nave	[kW]
02-12-2019 20:30:00.000	3.392.708.252	13.570,83	1.696,35
02-12-2019 20:45:00.000	3.392.623.291	13.570,49	1.696,31
02-12-2019 21:00:00.000	3.392.718.018	13.570,87	1.696,36
02-12-2019 21:15:00.000	3.392.343.994	13.569,38	1.696,17
02-12-2019 21:30:00.000	3.391.981.689	13.567,93	1.695,99
02-12-2019 21:45:00.000	3.391.866.699	13.567,47	1.695,93
02-12-2019 22:00:00.000	3.391.302.734	13.565,21	1.695,65
02-12-2019 22:15:00.000	3.391.157.227	13.564,63	1.695,58
02-12-2019 22:30:00.000	3.391.698.975	13.566,80	1.695,85
02-12-2019 22:45:00.000	3.391.767.578	13.567,07	1.695,88
02-12-2019 23:00:00.000	3.391.598.145	13.566,39	1.695,80
02-12-2019 23:15:00.000	3.391.532.471	13.566,13	1.695,77
02-12-2019 23:30:00.000	3.391.499.023	13.566,00	1.695,75
02-12-2019 23:45:00.000	3.391.222.900	13.564,89	1.695,61
03-12-2019 0:00:00.000	3.391.121.826	13.564,49	1.695,56
03-12-2019 0:15:00.000	3.390.980.957	13.563,92	1.695,49
03-12-2019 0:30:00.000	3.390.782.227	13.563,13	1.695,39
03-12-2019 0:45:00.000	3.390.446.533	13.561,79	1.695,22
03-12-2019 1:00:00.000	3.390.492.188	13.561,97	1.695,25
03-12-2019 1:15:00.000	3.364.242.676	13.456,97	1.682,12
03-12-2019 1:30:00.000	2.389.443.848	9.557,78	1.194,72
03-12-2019 1:45:00.000	2.374.554.932	9.498,22	1.187,28

FACTOR INTEGRACIÓN >> 0,000004 GENERADORES >> 8

SEGMENTO [KW]

1	1.696,33
2	1.696,27
3	1.695,96
4	1.695,61
5	1.695,87
6	1.695,78
7	1.695,68
8	1.695,53
9	1.695,31
10	1.688,68

POTENCIA TRAF0 LADO 66 KV - NAVE #2

Date/Time	kWh rec.int	kW/Novo	[kW]
05-12-2019 22:00:00.000	2.550.775,146	10.203,10	1.700,52
05-12-2019 22:15:00.000	2.549.566,162	10.198,26	1.699,71
05-12-2019 22:30:00.000	2.549.439,453	10.197,76	1.699,63
05-12-2019 22:45:00.000	2.549.263,916	10.197,06	1.699,51
05-12-2019 23:00:00.000	2.549.087,402	10.196,35	1.699,39
05-12-2019 23:15:00.000	2.548.889,648	10.195,56	1.699,26
05-12-2019 23:30:00.000	2.548.737,061	10.194,95	1.699,16
05-12-2019 23:45:00.000	2.549.023,682	10.196,09	1.699,35
06-12-2019 0:00:00.000	2.549.027,100	10.196,11	1.699,35
06-12-2019 0:15:00.000	2.548.913,086	10.195,65	1.699,28
06-12-2019 0:30:00.000	2.548.860,596	10.195,44	1.699,24
06-12-2019 0:45:00.000	2.548.731,445	10.194,93	1.699,15
06-12-2019 1:00:00.000	2.548.730,469	10.194,92	1.699,15
06-12-2019 1:15:00.000	2.548.598,389	10.194,39	1.699,07
06-12-2019 1:30:00.000	2.548.482,910	10.193,93	1.698,99
06-12-2019 1:45:00.000	2.548.525,146	10.194,10	1.699,02
06-12-2019 2:00:00.000	2.548.677,979	10.194,71	1.699,12
06-12-2019 2:15:00.000	2.548.674,316	10.194,70	1.699,12
06-12-2019 2:30:00.000	2.548.599,365	10.194,40	1.699,07
06-12-2019 2:45:00.000	2.548.701,172	10.194,80	1.699,13
06-12-2019 3:00:00.000	2.281.313,721	9.125,25	1.520,88
06-12-2019 3:15:00.000	1.784.871,826	7.139,49	1.189,91

6

0,000004 GENERADORES >>

FACTOR INTEGRACIÓN >>

SEGMENTO
[Kw]

1	1.700,11
2	1.699,57
3	1.699,33
4	1.699,25
5	1.699,31
6	1.699,20
7	1.699,11
8	1.699,00
9	1.699,12
10	1.699,10

POTENCIA TRAF0 LADO 66 KV - NAVE #3

Date/Time	kWh rec int	kW Nave	[kW]
04-12-2019 2:30:00.000	2.546.783.691	10.187.13	1.697,86
04-12-2019 2:45:00.000	2.546.725.098	10.186.90	1.697,82
04-12-2019 3:00:00.000	2.546.399.902	10.185.60	1.697,60
04-12-2019 3:15:00.000	2.546.146.729	10.184.59	1.697,43
04-12-2019 3:30:00.000	2.546.481.934	10.185.93	1.697,65
04-12-2019 3:45:00.000	2.546.718.750	10.186.88	1.697,81
04-12-2019 4:00:00.000	2.546.600.830	10.186.40	1.697,73
04-12-2019 4:15:00.000	2.546.675.293	10.186.70	1.697,78
04-12-2019 4:30:00.000	2.546.574.219	10.186.30	1.697,72
04-12-2019 4:45:00.000	2.546.622.070	10.186.49	1.697,75
04-12-2019 5:00:00.000	2.546.478.516	10.185.91	1.697,65
04-12-2019 5:15:00.000	2.546.585.205	10.186.34	1.697,72
04-12-2019 5:30:00.000	2.546.650.635	10.186.60	1.697,77
04-12-2019 5:45:00.000	2.546.671.631	10.186.69	1.697,78
04-12-2019 6:00:00.000	2.546.731.201	10.186.92	1.697,82
04-12-2019 6:15:00.000	2.546.406.250	10.185.63	1.697,60
04-12-2019 6:30:00.000	2.546.596.191	10.186.38	1.697,73
04-12-2019 6:45:00.000	2.546.548.340	10.186.19	1.697,70
04-12-2019 7:00:00.000	2.546.848.633	10.187.39	1.697,90
04-12-2019 7:15:00.000	2.547.246.338	10.188.99	1.698,16
04-12-2019 7:30:00.000	1.917.653.809	7.670.62	1.278,44
04-12-2019 7:45:00.000	1.785.743.652	7.142.97	1.190,50

FACTOR INTEGRACIÓN >> 0.000004 GENERADORES >> 6

SEGMENTO [Kw]

1	1.697,84	2	1.697,52	3	1.697,73	4	1.697,76	5	1.697,73	6	1.697,69	7	1.697,77	8	1.697,71	9	1.697,71	10	1.698,03
---	----------	---	----------	---	----------	---	----------	---	----------	---	----------	---	----------	---	----------	---	----------	----	----------

POTENCIA TRAF0 LADO 66 KV - NAVE #4

Date/Time	kWh rec int	kW Nave	[kW]
04-12-2019 20:15:00.000	2.482.289.795	9.929,16	1.654,86
04-12-2019 20:30:00.000	2.547.698.486	10.190,79	1.698,47
04-12-2019 20:45:00.000	2.547.547.607	10.190,19	1.698,37
04-12-2019 21:00:00.000	2.547.692.139	10.190,77	1.698,46
04-12-2019 21:15:00.000	2.547.935.547	10.191,74	1.698,62
04-12-2019 21:30:00.000	2.547.916.016	10.191,66	1.698,61
04-12-2019 21:45:00.000	2.548.024.658	10.192,10	1.698,68
04-12-2019 22:00:00.000	2.548.011.475	10.192,05	1.698,67
04-12-2019 22:15:00.000	2.547.888.672	10.191,55	1.698,59
04-12-2019 22:30:00.000	2.548.091.553	10.192,37	1.698,73
04-12-2019 22:45:00.000	2.547.893.066	10.191,57	1.698,60
04-12-2019 23:00:00.000	2.547.723.145	10.190,89	1.698,48
04-12-2019 23:15:00.000	2.546.821.777	10.187,29	1.697,88
04-12-2019 23:30:00.000	2.547.343.506	10.189,37	1.698,23
04-12-2019 23:45:00.000	2.547.218.750	10.188,88	1.698,15
05-12-2019 0:00:00.000	2.546.971.680	10.187,89	1.697,98
05-12-2019 0:15:00.000	2.546.948.486	10.187,79	1.697,97
05-12-2019 0:30:00.000	2.546.925.537	10.187,70	1.697,95
05-12-2019 0:45:00.000	2.547.179.932	10.188,72	1.698,12
05-12-2019 1:00:00.000	2.547.255.127	10.189,02	1.698,17
05-12-2019 1:15:00.000	2.401.741.455	9.606,97	1.601,16
05-12-2019 1:30:00.000	1.784.869.019	7.139,48	1.189,91
05-12-2019 1:45:00.000	1.784.853.882	7.139,42	1.189,90

FACTOR INTEGRACIÓN >> 0,000004 GENERADORES >> 6

SEGMENTO [kW]

1	1.676,66
2	1.698,41
3	1.698,62
4	1.698,68
5	1.698,66
6	1.698,54
7	1.698,06
8	1.698,06
9	1.697,96
10	1.698,15

SSAA NAVE #1

TIME STAMP	POTENCIA ACTIVA SSAA
[hh:mm:ss]	[kW]
20:30:00	159,48
20:30:45	164,42
20:31:30	159,48
20:32:15	163,19
20:33:00	161,12
20:33:45	162,15
20:34:30	163,80
20:35:15	163,70
20:36:00	160,71
20:36:45	159,48
20:37:30	163,19
20:38:15	164,42
20:39:00	159,48
20:39:45	163,80
20:40:30	161,95
20:41:15	164,73
20:42:00	163,19
20:42:45	163,60
20:43:30	161,23
20:44:15	160,71
20:45:00	166,89
20:45:45	168,75

SEGMENTO
[kW]
[kW] por Generador

1	2	3	4	5	6	7	8	9	10
161,95	161,33	161,64	163,75	160,09	163,80	161,64	163,34	163,39	160,97
20,24	20,17	20,20	20,47	20,01	20,48	20,20	20,42	20,42	20,12

SSAA NAVE #2

TIME STAMP [hh:mm:ss]	POTENCIA ACTIVA SSAA [kW]
22:00:00	121,63
22:15:00	120,25
22:30:00	122,78
22:45:00	121,63
23:00:00	124,39
23:15:00	118,86
23:30:00	125,78
23:45:00	118,86
00:00:00	121,07
00:15:00	118,86
00:30:00	121,94
00:45:00	124,39
01:00:00	119,79
01:15:00	118,86
01:30:00	121,63
01:45:00	122,55
02:00:00	118,86
02:15:00	118,86
02:30:00	121,63
02:45:00	119,79
03:00:00	124,39
03:15:00	122,01

SEGMENTO [kW]
[kW] por Generador

1	2	3	4	5	6	7	8	9	10
120,94	122,20	121,63	122,32	119,97	123,16	119,33	122,09	118,86	120,71
20,16	20,37	20,27	20,39	19,99	20,53	19,89	20,35	19,81	20,12

SSAA NAVE #3

TIME STAMP [hh:mm:ss]	POTENCIA ACTIVA SSAA [kW]	SEGMENTO [kW]
02:30:00	118,75	
02:45:00	125,90	
03:00:00	118,75	
03:15:00	122,67	
03:30:00	120,05	
03:45:00	122,06	
04:00:00	119,97	
04:15:00	120,98	
04:30:00	121,97	
04:45:00	118,98	
05:00:00	118,75	
05:15:00	122,21	
05:30:00	120,59	
05:45:00	122,90	
06:00:00	121,51	
06:15:00	122,06	
06:30:00	121,51	
06:45:00	120,37	
07:00:00	122,66	
07:15:00	121,75	

1	2	3	4	5	6	7	8	9	10
122,32	120,71	121,05	120,48	120,48	120,48	121,74	121,78	120,94	122,20
20,39	20,12	20,18	20,08	20,08	20,08	20,29	20,30	20,16	20,37

SSAA NAVE #4

TIME STAMP [hh:mm:ss]	POTENCIA ACTIVA SSAA [kW]	SEGMENTO [kW]
20:15:00	118,97	
20:30:00	118,85	
20:45:00	120,84	
21:00:00	117,68	
21:15:00	124,52	
21:30:00	117,68	
21:45:00	120,99	
22:00:00	119,38	
22:15:00	121,67	
22:30:00	120,87	
22:45:00	117,68	
23:00:00	117,68	
23:15:00	120,87	
23:30:00	120,75	
23:45:00	117,79	
00:00:00	119,50	
00:15:00	121,55	
00:30:00	120,41	
00:45:00	120,72	
01:00:00	120,72	

1	2	3	4	5	6	7	8	9	10
118,91	119,26	121,10	120,18	121,27	117,68	120,81	118,65	120,98	120,72
19,82	19,88	20,18	20,03	20,21	19,61	20,13	19,77	20,16	20,12

ANEXO II

Diagrama unifilar de la planta

ANEXO III

Especificaciones de los equipos de medición

PowerLogic™ ION8650

Energy and power quality meter

User manual

7EN02-0306-03
10/2018

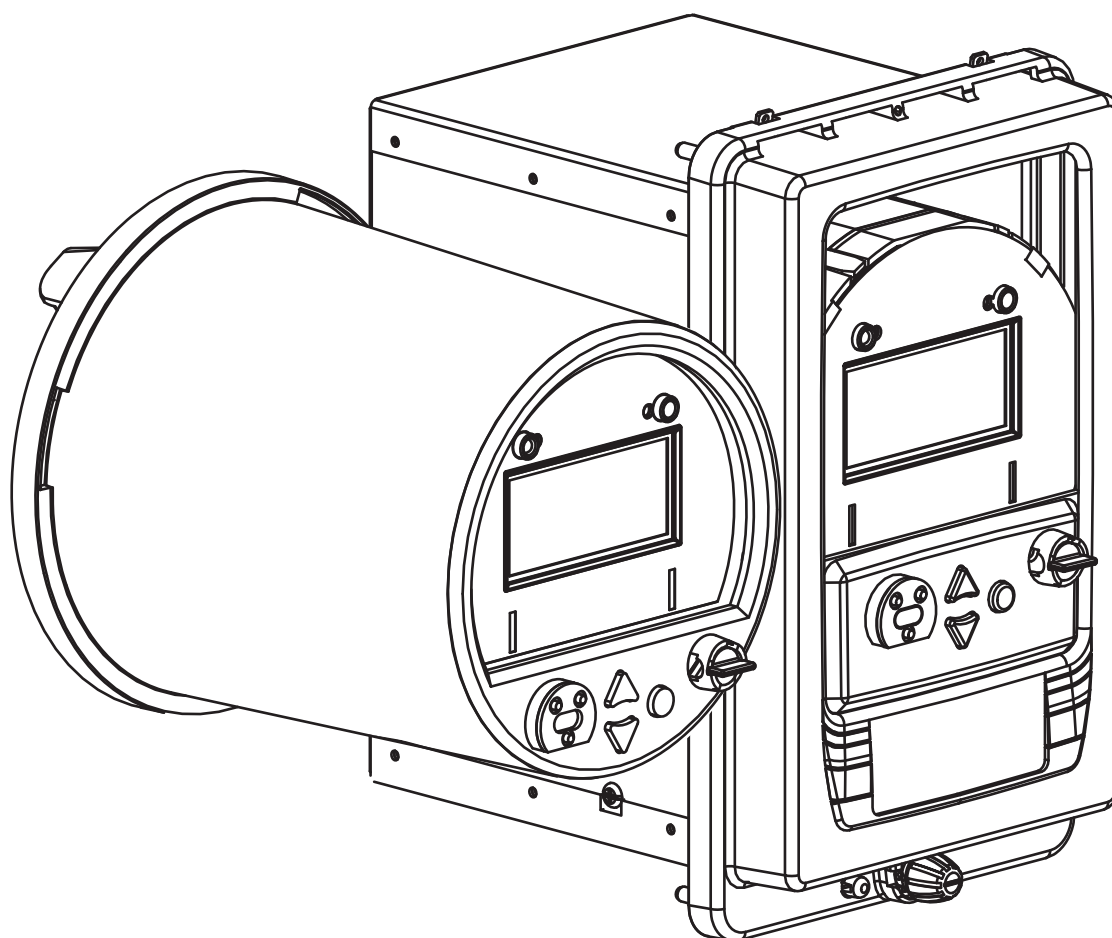

Chapter 2 Introduction

PowerLogic™ ION8650 meters provide revenue-accurate, true RMS measurements of voltage, current, power and energy, and are complemented by extensive I/O capabilities, comprehensive logging, and advanced power quality measurement and compliance verification functions. The meters come with an extensive selection of preconfigured data screens and measurements, so you can use the meters with their default configuration after you perform basic setup. You can also customize the meter to fit your unique requirements.

ION8650 meters give you the tools to manage complex energy supply contracts that include commitments to power quality. You can also integrate the meters with energy management solutions such as StruxureWare™ Power Monitoring Expert (originally ION Enterprise), SCADA, automation and billing systems via Internet communications and multiple industry-standard communication channels and protocols including MV-90 and IEC 61850.

In this chapter

- ION8650 meters 12
- ION8650 in enterprise energy management systems 13
 - The meter is factory-configured and ready to operate 13
- Measured Parameters 13
 - Energy 14
 - Demand 14
 - Instantaneous 14
 - Harmonics 14
 - Min/Max recording 14
 - Power quality 15
- Data display and analysis tools 15
 - The front panel 15
 - WebMeter internal web server feature 15
 - Meter internal email server feature 16
 - XML compatibility 16
 - Power Monitoring Expert software 16
 - ION Setup device configuration tool 16
 - MV-90 16
 - IEC 61850 16
 - Alerting 17
- Communications methods 17
- Security 17
- Digital and analog I/O options 18
 - Onboard I/O 18
 - Expanded I/O 18
 - Additional information 19

ION8650 meters

The meter is suited to a wide range of applications. The meters can be used as stand-alone devices, but their extensive capabilities are fully realized when used as part of an enterprise energy management (EEM) system. The ION8650 is available with the following feature sets:

Model	Feature set
ION8650A	128MB memory, 50 data recorders (800 channels), 4-30 Class A + EN50160 power quality analysis (waveforms and transient detection)
ION8650B	64MB memory, 45 data recorders (720 channels), 4-30 Class S + EN50160 power quality monitoring
ION8650C	32MB memory, 5 data recorders (80 channels)

NOTE: For complete details of the ION8650 meter feature sets, see the ION8650 Datasheet available from www.schneider-electric.com.

ION8650 naming convention

In the serial number and ANSI bar code area of the meter's front panel you can view the feature set, form factor and any special order options available with the meter. For example:

S8650A0C0H6E0B0A			
S8650	Brand and model	H6	Power supply and system frequency
A0	Feature set and form factor	E0	Communications
C0	Voltage/current inputs	B0A	I/O, security and special options

When there are differences between the models (such as a feature specific to one model), it is indicated with the appropriate model number in this document.

ION8650 in enterprise energy management systems

Applications that include the meter typically require additional equipment. Display and analysis software tools are almost always used to manage, interpret and distribute the data measured or logged by a meter. There are usually a variety of tools used, and often these tools are connected using different communications standards and protocols.

The meter can adapt to many situations. Advanced communications allow data to be shared simultaneously across multiple networks, built-in I/O provides monitoring and non-critical control capabilities, and a variety of display and analysis tools can be used to monitor your power system.

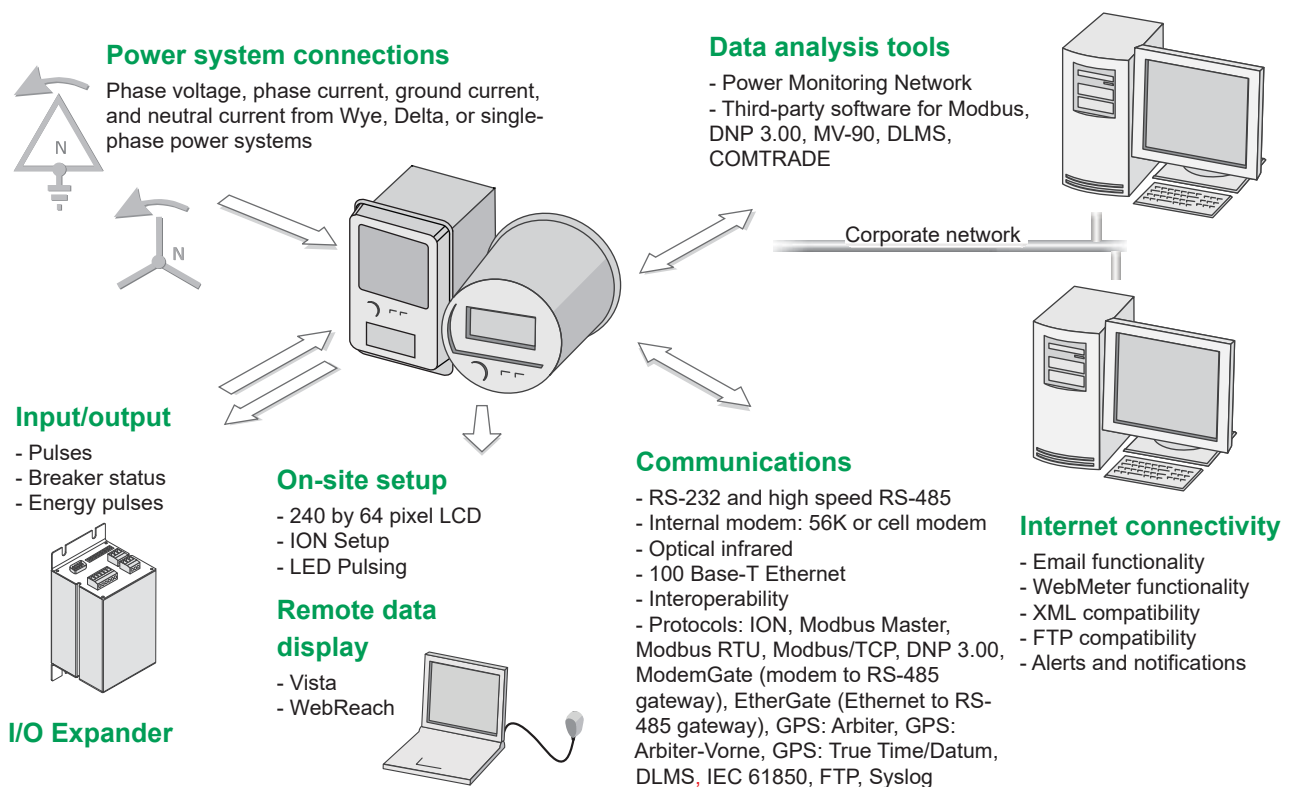

The meter is factory-configured and ready to operate

Your meter is preconfigured to provide most of the functionality needed in many applications. After you perform the installation and basic setup, all of the basic measurements, energy calculations and recording functions are ready to operate. The meter can also be fully customized if necessary to meet your needs.

Measured Parameters

The meter provides fully bi-directional, 4-quadrant, revenue accurate energy metering. The following sections list some of the parameters measured by the meter.

Energy

The meter provides all common active, reactive and apparent energy parameters.

- kWh, kVARh, kVAh delivered and received
- kWh, kVARh, kVAh net (delivered - received)
- kWh, kVARh, kVAh total (delivered + received)
- Volt-hours and amp-hours
- Integration of any instantaneous measurement

Energy registers can be logged automatically on a programmed schedule. All energy parameters represent the total for all three phases.

Demand

The meter supports standard demand calculation methods, including block, sliding window (rolling block), and predicted demand. It can measure demand on any instantaneous value and record peak (maximum) and minimum demand with date and timestamps to the second. Peak demand registers can be reset manually (password protected) or logged and reset automatically on a programmed schedule.

Measurements include:

- kW, kVAR, kVA demand, min/max
- Amps, Volts demand, min/max
- Demand on any instantaneous measurement

Instantaneous

The meter provides highly accurate, 1 second or 1/2 cycle measurements, including true RMS, per phase and total for:

- Voltage and current
- Active power (kW) and reactive power (kVAR)
- Apparent power (kVA)
- Power factor and frequency
- Voltage and current unbalance
- Phase reversal

Harmonics

Complete harmonic distortion metering, recording and real-time reporting, up to the 63rd harmonic for all voltage and current inputs.

- Individual harmonics (including magnitude, phase and inter-harmonics)
- Total even harmonics and total odd harmonics
- Total harmonics (even + odd)
- K-factor, Crest factor

Min/Max recording

The meter records each new minimum and new maximum value with date and time-stamp for the following parameters:

- Voltage and current min/max

- kW, kVAR, and kVA min/max
- Power factor
- Frequency
- Voltage unbalance
- Plus any measured value

Power quality

The meter measures and records the following parameters:

- Sag/Swells
- Transients (ION8650A only)

The meter also has the following power quality features:

- **Disturbance direction detection:** This allows the meter to analyze disturbance (sag/swell) information to help determine the direction of the disturbance relative to the meter.
- **EN50160:** ION8650A and ION8650B meters have a default framework that measures and presents EN50160 compliance according to guidelines defined by Eurelectric (UNIPED).
- **IEC 61000-4-30:** The meter complies with the IEC 61000-4-30 power quality standard as follows:
 - The ION8650A complies with IEC 61000-4-30 Class A.
 - The ION8650B complies with IEC 61000-4-30 Class S.
- **COMTRADE:** ION8650A meters can save waveform data in COMMon Format for TRAnsient Data Exchange (COMTRADE) format, which is then available for download via FTP. This is intended for use in conjunction with IEC 61850 and is only available on ION8650A meters with an Ethernet port.

Data display and analysis tools

The meter integrates seamlessly with display and analysis software available from Schneider Electric™, such as Power Monitoring Expert that lets you analyze and monitor your system and produce reports for any department in an organization. Power Monitoring Expert is designed to make use of your meter's advanced capabilities. You can also use data acquired by the meter in a variety of third-party systems.

The front panel

Local monitoring and standalone applications are facilitated by the meter's front panel interface. The front panel combines real-time display features with basic device configuration functions. The front panel is often used in combination with Power Monitoring Expert or ION Setup, providing an interface for field personnel.

WebMeter internal web server feature

WebMeter™ provides quick and easy access to real-time energy and basic power quality information without special software using an on-board web server combined with an Ethernet port. The built-in web pages display a range of energy and basic power quality information through the web-enabled device; these pages also support basic meter configuration tasks.

Meter internal email server feature

You can configure your meter to automatically email high-priority alarm notifications or scheduled system-status update messages to an external email address. Specify the type of event that triggers an email alert, such as power quality disturbances or logged data at any pre-determined interval, and have your Power Monitoring Expert or ION Setup administrator program the meter to respond with an email message when these events occur. Email messages from your meter can be received like any email message.

XML compatibility

The meters can exchange information using industry-standard XML format. This simple machine-readable format supports integration with custom reporting, spreadsheet, database, and other applications.

Power Monitoring Expert software

Power Monitoring Expert allows the meter to be part of a fully networked information system with other meters and local and wide-area computer networks. Power Monitoring Expert is recommended for all power monitoring systems where advanced analysis and non-critical control capabilities are required.

Power Monitoring Expert provides tools for managing your power monitoring network, logging data, analyzing real-time and logged data, generating power system reports, and creating custom functionality at the meter level.

Power Monitoring Expert also offers ways to remotely view information through a web browser: for example, through the WebReach and Web Reporter components of Power Monitoring Expert, and through Microsoft Terminal Services.

See the Power Monitoring Expert Help for more information.

ION Setup device configuration tool

ION Setup is a meter configuration tool designed specifically to configure and test meters. ION Setup offers a graphical interface for performing basic meter setup, installing templates into meters, upgrading firmware, viewing real-time and reset accumulated values, verifying meter accuracy and measurements, and setting up advanced security.

You can download ION Setup from www.schneider-electric.com. It is recommended that you always upgrade to the latest version of ION Setup to help properly configure the features available on your device.

MV-90

MV-90 software (by Utility Translation Systems) is a multi-vendor translation system that can collect and analyze data from a variety of different brands of meters, each with unique database formats. MV-90 manipulates this data without extensive knowledge of the device of origin.

For more information on using the meter in an MV-90 system, see the *MV-90 and ION Technology* technical note.

IEC 61850

IEC 61850 is an Ethernet-based protocol designed for electrical substations. It is a standard (vendor-independent) method of communications, developed to support

integrated systems composed of multi-vendor, self-describing devices. When properly configured, the meter acts as a server in an IEC 61850 system. This meter supports IEC 61850:2010 (Edition 2).

Alerting

The meter can be configured to send alerts in response to power system conditions that you define, such as a power quality problem (including surges, sags and swells), changes in relays, power outages or required equipment maintenance. This allows you to automatically advise key people of problems to allow quick remedial action, notify software so logs can be uploaded from the site that initiated the alert, or service equipment on schedule.

You can configure the meter to send alerts to email, pagers, outage notification servers or to software such as Power Monitoring Expert.

For more information on configuring alerting on the meter, see the *ION meter alerts* technical note and the Alert module description in the *ION Reference*. For more information on configuring alerting in Power Monitoring Expert, see the online *Power Monitoring Expert help*.

For more information on Ethernet outage notification, see the *Outage notifications on the PowerLogic ION8650* product option document.

Communications methods

The meter can be integrated into various industry-standard networks. Data from the meter can be made available to other devices using the Modbus™ Master, Modbus RTU, Modbus TCP, DLMS and DNP 3.0 protocols, as well the MV-90 translation system. You can also configure the meter to import data from devices on these networks. With these advanced communications functions, the meter operates in most existing power monitoring systems. Any data display and analysis software that works with these protocols also functions with the meter.

The standard meter includes a selectable RS-232/RS-485 port, a high-speed RS-485 port, and an optical port for communications in the field. Order options include a 10/100Base-T Ethernet port, 57.6 kbps internal modem (both FCC and CTR-21 compliant) and an internal cellular modem. Depending on the hardware options purchased, up to four separate ports can communicate simultaneously.

Security

This meter offers standard and advanced security. Standard security is enabled by default from the factory, and advanced security allows you to configure specific security settings. These include features such as adding users with unique access privileges, and communications lockouts.

There are also additional features available on the meter that are based on the North American Electrical Reliability Corporation Critical Infrastructure Protection (NERC CIP) standards, allowing this meter to assist in making your facility NERC CIP compliant. These additional features include advanced security through the front panel, communications and network port enabling and disabling, Ethernet port number assignment and event log loss preventative measures.

Digital and analog I/O options

Onboard I/O

There are two optional onboard I/O configurations available, each providing different capabilities. The number and form of the digital inputs and outputs depend on the option you ordered; see your meter's *Installation Guide* to determine the configuration available on your meter.

Additionally, two infrared ports (and corresponding LEDs) on the front panel are configured by default for energy pulsing.

Digital inputs

The meter can be ordered with internally or externally-excited Form A digital inputs. They can be used for tariff inputs and other pulse counting applications.

Digital outputs

The meter can be ordered with both Form C and Form A solid-state outputs.

Expanded I/O

The I/O Expander option extends the meter's I/O capabilities. The digital I/O Expander model provides four Form A digital outputs, four Form C digital outputs, and eight Form A digital inputs. The analog I/O Expander model replaces the four form A digital outputs with analog outputs.

Refer to the *PowerLogic I/O Expander Installation Guide* for details on the options and installation and operation instructions.

Additional information

The most up-to-date documentation about your meter is available for download from www.schneider-electric.com. Available documentation includes:

Installation guides

This document is shipped with each meter. It details the mounting, wiring and basic setup of the device. There is a separate installation guide for the socket and the switchboard versions of the meter.

I/O Expander installation guide

This document describes the optional external I/O device that you can connect to the meter, for additional digital I/O and analog output ports.

Product option documents

These documents provide option-specific information about the various product options you can order for the meter. They usually ship with the product.

Online ION Setup help

The online ION Setup help has in-depth information on installation, setup and security of ION Setup. It also contains instructions on using the Setup Assistant to configure devices.

ION Reference

This document describes ION architecture and provides detailed descriptions of all ION modules in all ION meters.

Online Power Monitoring Expert help

The Power Monitoring Expert online help system provides information and instructions on using Power Monitoring Expert components.

Technical notes

Technical notes such as the EN50160 technical note are available from the website, and provide instructions for using meter features and for creating custom configurations.

Protocol documents

Each protocol document contains information explaining how the product interacts with a protocol, such as DNP 3.0, DLMS, Modicon Modbus, IEC 61850 and MV-90.

ION device template reference

This document lists the default ION modules and their default configuration in the shipping template for the most recent firmware releases of ION meters.

Micro Motion® R-Series Coriolis Flow Sensors



Safety and approval information

This Micro Motion product complies with all applicable European directives when properly installed in accordance with the instructions in this manual. Refer to the EU declaration of conformity for directives that apply to this product. The EU declaration of conformity, with all applicable European directives, and the complete ATEX Installation Drawings and Instructions are available on the internet at www.emerson.com or through your local Micro Motion support center.

Information affixed to equipment that complies with the Pressure Equipment Directive, can be found on the internet at www.emerson.com.

For hazardous installations in Europe, refer to standard EN 60079-14 if national standards do not apply.

Other information

Full product specifications can be found in the product data sheet. Troubleshooting information can be found in the configuration manual. Product data sheets and manuals are available from the Micro Motion web site at www.emerson.com.

Return policy

Follow Micro Motion procedures when returning equipment. These procedures ensure legal compliance with government transportation agencies and help provide a safe working environment for Micro Motion employees. Micro Motion will not accept your returned equipment if you fail to follow Micro Motion procedures.

Return procedures and forms are available on our web support site at www.emerson.com, or by phoning the Micro Motion Customer Service department.

Emerson Flow customer service

Email:

- Worldwide: flow.support@emerson.com
- Asia-Pacific: APflow.support@emerson.com

Telephone:

North and South America		Europe and Middle East		Asia Pacific	
United States	800-522-6277	U.K.	0870 240 1978	Australia	800 158 727
Canada	+1 303-527-5200	The Netherlands	+31 (0) 704 136 666	New Zealand	099 128 804
Mexico	+41 (0) 41 7686 111	France	0800 917 901	India	800 440 1468
Argentina	+54 11 4837 7000	Germany	0800 182 5347	Pakistan	888 550 2682
Brazil	+55 15 3413 8000	Italy	8008 77334	China	+86 21 2892 9000
		Central & Eastern	+41 (0) 41 7686 111	Japan	+81 3 5769 6803
		Russia/CIS	+7 495 981 9811	South Korea	+82 2 3438 4600
		Egypt	0800 000 0015	Singapore	+65 6 777 8211
		Oman	800 70101	Thailand	001 800 441 6426
		Qatar	431 0044	Malaysia	800 814 008
		Kuwait	663 299 01		
		South Africa	800 991 390		
		Saudi Arabia	800 844 9564		
		UAE	800 0444 0684		

Contents

Chapter 1	Planning	1
	1.1 Installation checklist	1
	1.2 Best practices	2
	1.3 Temperature limits	2
Chapter 2	Mounting	4
	2.1 Mount the sensor	4
Chapter 3	Transmitter power and I/O wiring	5
	3.1 Options for wiring	5
	3.2 Connect 4-wire cable	6
Chapter 4	Grounding	10
Chapter 5	Purge the sensor case	11
	5.1 Pressure relief	12

1 Planning

Topics covered in this chapter:

- *Installation checklist*
- *Best practices*
- *Temperature limits*

1.1 Installation checklist

- Make sure that the hazardous area specified on the approval tag is suitable for the environment in which the meter will be installed.
- Verify that the local ambient and process temperatures are within the limits of the meter.
- If your sensor has an integral transmitter, no wiring is required between the sensor and transmitter. Follow the wiring instructions in the transmitter installation manual for signal and power wiring.
- If your transmitter has remote-mounted electronics, follow the instructions in this manual for wiring between the sensor and the transmitter, and then follow the instructions in the transmitter installation manual for power and signal wiring.

Table 1-1: Maximum cable lengths

Cable type	To transmitter	Maximum length
Micro Motion 4-wire	All 4-wire MVD transmitters	<ul style="list-style-type: none"> - 1000 ft (300 m) without Ex-approval - 500 ft (150 m) with IIC rated sensors - 1000 ft (300 m) with IIB rated sensors

Table 1-2: Maximum lengths for user-supplied 4-wire cable

Wire function	Wire size	Maximum length
Power (VDC)	22 AWG (0,35 mm ²)	300 ft (90 m)
	20 AWG (0,5 mm ²)	500 ft (150 m)
	18 AWG (0,8 mm ²)	1000 ft (300 m)
Signal (RS-485)	22 AWG (0,35 mm ²) or larger	1000 ft (300 m)

- For optimal performance, install the sensor in the preferred orientation. The sensor will work in any orientation as long as the flow tubes remain full of process fluid.

Table 1-3: Preferred sensor orientation

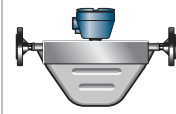
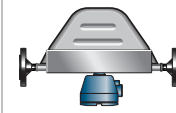
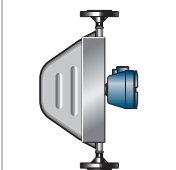
Liquids	
Gases	
Slurries	

- Install the meter so that the flow direction arrow on the sensor case matches the actual forward flow of the process. (Flow direction is also software-selectable.)

1.2 Best practices

The following information can help you get the most from your sensor.

- There are no pipe run requirements for Micro Motion sensors. Straight runs of pipe upstream or downstream are unnecessary.
- If the sensor is installed in a vertical pipeline, liquids and slurries should flow upward through the sensor.
- For halting flow through the sensor with a single valve, install the valve downstream from the sensor.
- The sensor does not require external supports. The flanges will support the sensor in any orientation.

1.3 Temperature limits

Sensors can be used in the process and ambient temperature ranges shown in the temperature limit graphs. For the purposes of selecting electronics options, temperature limit graphs should be used only as a general guide. If your process conditions are close to the gray area, consult with your Micro Motion representative.

Note

- In all cases, the electronics cannot be operated where the ambient temperature is below $-40\text{ }^{\circ}\text{F}$ ($-40\text{ }^{\circ}\text{C}$) or above $+140\text{ }^{\circ}\text{F}$ ($+60\text{ }^{\circ}\text{C}$). If a sensor is to be used where the ambient temperature is outside of the range permissible for the electronics, the electronics must be remotely located where the ambient temperature is within the permissible range, as indicated by the shaded areas of the temperature limit graphs.

- Temperature limits may be further restricted by hazardous area approvals. Refer to the hazardous area approvals documentation shipped with the sensor or available at www.emerson.com.
- The extended-mount electronics option allows the sensor case to be insulated without covering the transmitter, core processor, or junction box, but does not affect temperature ratings. When insulating the sensor case at elevated process temperatures (above 140 °F), please ensure electronics are not enclosed in insulation as this may lead to electronics failure.

Ambient and process temperature limits for all models: 316L stainless steel (S) and high pressure (P)

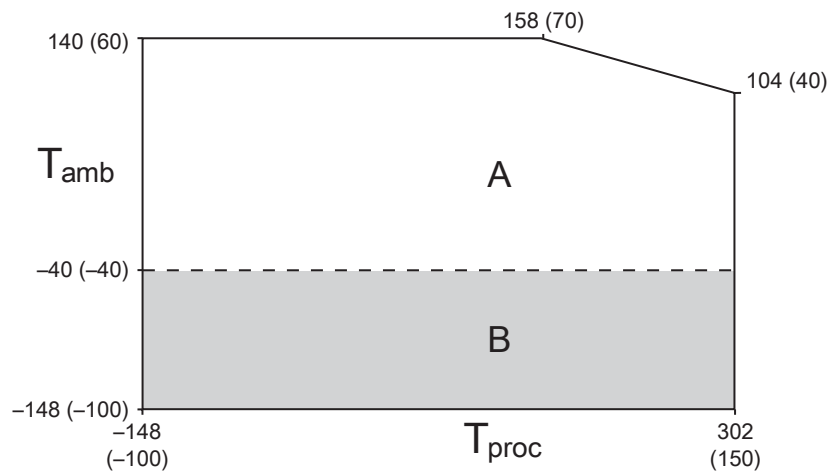

T_{amb} = Ambient temperature °F (°C)

T_{proc} = Process temperature °F (°C)

A = All available electronic options

B = Remote mount electronics only

2 Mounting

2.1 Mount the sensor

Use your common practices to minimize torque and bending load on process connections.

Tip

To reduce the risk of condensation problems, do not orient transmitters or sensor junction boxes with their conduit openings pointing upward.

⚠ CAUTION!

Do not lift the sensor by the electronics. Lifting the sensor by the electronics can damage the device.

Figure 2-1: Mounting the sensor

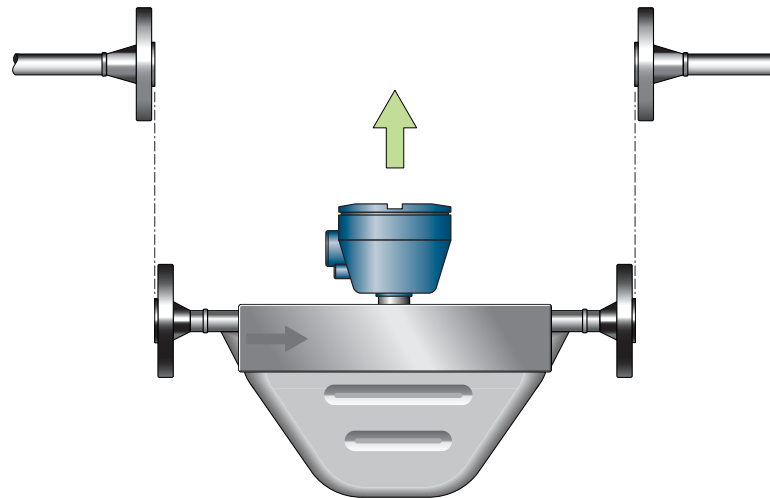

Notes

- Do not use the sensor to support the piping.
 - The sensor does not require external supports. The flanges will support the sensor in any orientation.
-

3 Transmitter power and I/O wiring

Topics covered in this chapter:

- *Options for wiring*
- *Connect 4-wire cable*

3.1 Options for wiring

The wiring procedure you follow depends on which electronics option you have.

Table 3-1: Wiring procedures by electronics option

Electronics option	Wiring procedure
Integral transmitter	The transmitter is already connected to the sensor. No wiring is required between sensor and transmitter. See the transmitter installation manual for wiring the power and signal cable to the transmitter.
MVD™ Direct Connect™	There is no transmitter to wire. See the MVD Direct Connect manual for wiring the power and signal cable between the sensor and the direct host.
Integral core processor with remote transmitter	The core processor is already connected to the sensor. Connect a 4-wire cable between the core processor and transmitter. Refer to Section 3.2 .

DANGER!

Make sure the hazardous area specified on the sensor approval tag is suitable for the environment in which the sensor will be installed. Failure to comply with the requirements for intrinsic safety in a hazardous area could result in an explosion.

CAUTION!

Fully close and tighten all housing covers and conduit openings. Improperly sealed housings can expose electronics to moisture, which can cause measurement error or flowmeter failure. Inspect and grease all gaskets and O-rings.

3.2 Connect 4-wire cable

3.2.1 4-wire cable types and usage

Micro Motion offers two types of 4-wire cable: shielded and armored. Both types contain shield drain wires.

The cable supplied by Micro Motion consists of one pair of red and black 18 AWG 0.75 mm² wires for the VDC connection, and one pair of white and green 22 AWG 0.35 mm² wires for the RS-485 connection.

User-supplied cable must meet the following requirements:

- Twisted pair construction.
- Applicable hazardous area requirements, if the core processor is installed in a hazardous area.
- Wire gauge appropriate for the cable length between the core processor and the transmitter, or the host.

Table 3-2: Wire gauge

Wire gauge	Maximum cable length
VDC 22 AWG (0.35 mm ²)	300 ft (90 m)
VDC 20 AWG (0.5 mm ²)	500 ft (150 m)
VDC 18 AWG (0.8 mm ²)	1000 ft (300 m)
RS-485 22 AWG (0.35 mm ²) or larger	1000 ft (300 m)

3.2.2 Prepare a cable with a metal conduit

1. Remove the core processor cover using a flat-blade screw driver.
2. Run the conduit to the sensor.
3. Pull the cable through the conduit.
4. Cut the drain wires and let them float at both ends of the conduit.

3.2.3 Prepare a cable with user-supplied cable glands

1. Remove the core processor cover using a flat-blade screw driver.
2. Pass the wires through the gland nut and gland body.

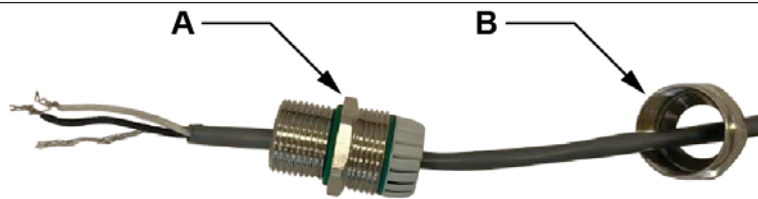

A. Gland body
B. Gland nut

3. Terminate the RS-485 shield and drain wires to the housing internal grounding screw.
4. Assemble the gland according to vendor instructions.

3.2.4 Prepare a cable with Micro Motion-supplied cable glands

1. Remove the core processor cover using a flat-blade screw driver.
2. Pass the wires through the gland nut and clamping insert.

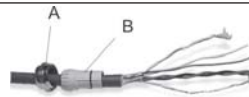

A. Gland nut
B. Clamping insert

3. Strip the cable jacket.

Option	Description
NPT gland type	Strip 4-1/2 inch (115 mm)
M20 gland type	Strip 4-1/4 inch (108 mm)

4. Remove the clear wrap and filler material.
5. Strip most of the shielding.

Option	Description
NPT gland type	Strip all but 3/4 inch (19 mm)
M20 gland type	Strip all but 1/2 inch (12 mm)

6. Wrap the drain wires twice around the shield and cut off the excess drain wires.





A. Drain wires wrapped around shield

7. For foil (shielded cable) only:

Note

For braided (armored cable) skip this step and continue to the next step.

Option	Description
NPT gland type	<p>a. Slide the shielded heat shrink over the drain wires. Ensure that the wires are completely covered.</p> <p>b. Apply heat (250 °F or 120 °C) to shrink the tubing. Do not burn the cable.</p> <p>c. Position the clamping insert so the interior end is flush with the braid of the heat shrink.</p> <div style="text-align: center;">  </div> <p>A. Shielded heat shrink B. After heat is applied</p>
M20 gland type	<p>Trim 0.3 in (7 mm).</p> <div style="text-align: center;">  </div> <p>A. Trim</p>

8. Assemble the gland by folding the shield or braid back over the clamping insert and 1/8 inch (3 mm) past the O-ring.

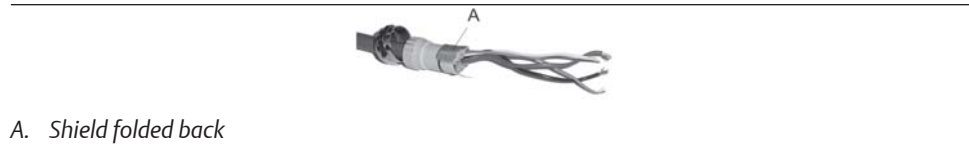

9. Install the gland body into the conduit opening on the core processor housing.
10. Insert the wires through the gland body and tighten the gland nut onto the gland body.

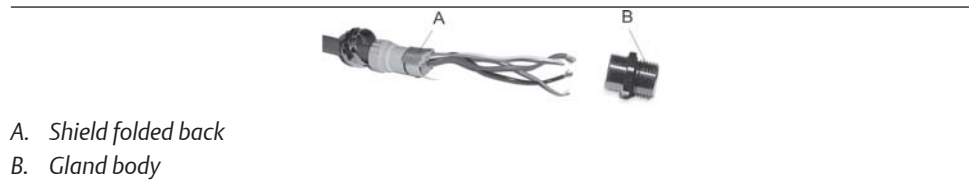

3.2.5 Connect the wires to the core processor terminals

After the 4-wire cable has been prepared and shielded (if required), connect the individual wires of the 4-wire cable to the terminals on the core processor.

1. Connect the wires to the core processor terminals.

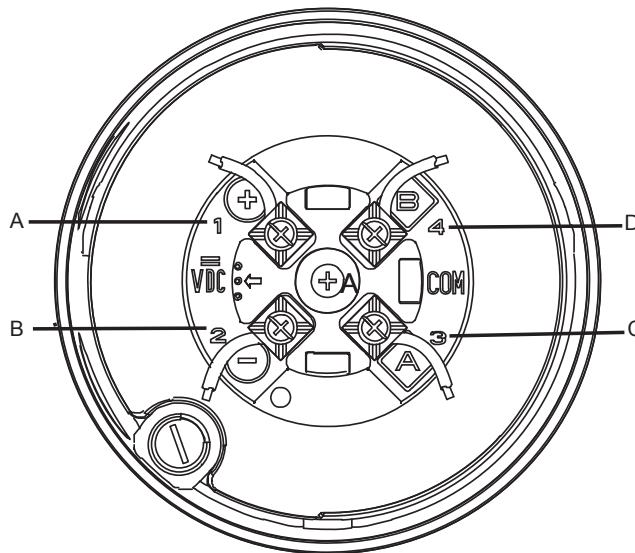

- A. Terminal 1 (Power supply +): Red wire
- B. Terminal 2 (Power supply -): Black wire
- C. Terminal 3 (RS-485/A): White wire
- D. Terminal 4 (RS-485/B): Green wire

2. Reinstall the core processor cover.
3. Torque the cover screws to:
 - 10–13 lbf-in. (1.13–1.47 N-m) for an aluminum housing
 - minimum 19 lbf-in. (2.1 N-m) for a stainless steel housing

If properly seated, there will be no gap between cover and base.
4. Connect the wires to the transmitter terminals using the transmitter installation manual.

4 Grounding

The meter must be grounded according to the standards that are applicable at the site. The customer is responsible for knowing and complying with all applicable standards.

Prerequisites

Micro Motion suggests the following guides for grounding practices:

- In Europe, IEC 79-14 is applicable to most installations, in particular Sections 12.2.2.3 and 12.2.2.4.
- In the U.S.A. and Canada, ISA 12.06.01 Part 1 provides examples with associated applications and requirements.

If no external standards are applicable, follow these guidelines to ground the sensor:

- Use copper wire, 14 AWG (2,0 mm²) or larger wire size.
- Keep all ground leads as short as possible, less than 1 Ω impedance.
- Connect ground leads directly to earth, or follow plant standards.

CAUTION!

Ground the flowmeter to earth, or follow ground network requirements for the facility. Improper grounding can cause measurement error.

Procedure

Check the joints in the pipeline.

- If the joints in the pipeline are ground-bonded, the sensor is automatically grounded and no further action is necessary (unless required by local code).
- If the joints in the pipeline are not grounded, connect a ground wire to the grounding screw located on the sensor electronics.

Tip

The sensor electronics may be a transmitter, core processor, or junction box. The grounding screw may be internal or external.

5 Purge the sensor case

Whenever a purge plug is removed from the sensor case, you must repurge the case.

Prerequisites

Make sure the following are available before beginning the purge procedure:

- Teflon™ tape
- Argon or nitrogen gas sufficient to purge the sensor case

Procedure

1. Shut down the process, or set control devices for manual operation. Before performing the case purging procedure, shut down the process or set the control devices for manual operation. Performing the purge procedure while the flowmeter is operating could affect measurement accuracy, resulting in inaccurate flow signals.
2. Remove both purge plugs from the sensor case. If purge lines are being used, open the valve in the purge lines.

DANGER!

- **Stay clear of the rupture disk pressure relief area. High-pressure fluid escaping from the sensor can cause severe injury or death. The sensor must be oriented so that personnel and equipment will not be exposed to any discharge along the pressure relief path.**
- **Take all necessary precautions when removing purge plugs. Removing a purge plug compromises the secondary containment of the sensor and could expose the user to process fluid.**
- **Improper pressurization of the sensor case could result in personal injury.**

CAUTION!

Be sure to use thread protectors when removing the purge fitting so as not to damage the disk membrane surrounding the rupture disk.

3. Prepare the purge plugs for reinstallation by wrapping them with 2–3 turns of Teflon tape.
4. Connect the supply of nitrogen or argon gas to the inlet purge connection or open inlet purge line. Leave the outlet connection open.
 - Exercise caution to avoid introducing dirt, moisture, rust, or other contaminants into the sensor case.
 - If the purge gas is heavier than air (such as argon), locate the inlet lower than the outlet, so that the purge gas will displace air from bottom to top.
 - If the purge gas is lighter than air (such as nitrogen), locate the inlet higher than the outlet, so that the purge gas will displace air from top to bottom.

5. Make sure that there is a tight seal between the inlet connection and sensor case, so that air cannot be drawn by suction into the case or purge line during the purging process.
6. Run purge gas through the sensor.

The purge time is the amount of time required for full exchange of atmosphere to inert gas. The larger the line size, the greater amount of time is required to purge the case. If purge lines are being used, increase the purge time to fill the additional volume of the purge line.

Note

Keep the purge gas pressure below 0.5 bar (7 psi).

Table 5-1: Purge time

Sensor model	Purge rate, in ft ³ /hr (l/h)	Time, in minutes
R025	20 (566)	4 1/2
R050	20 (566)	4 1/2
R100	20 (566)	6
R200	20 (566)	15

7. At the appropriate time, shut off the gas supply, then immediately seal the purge outlet and inlet connections with the purge plugs.

Avoid pressurizing the sensor case. If pressure inside the case elevates above atmospheric pressure during operation, the flowmeter density calibration will be inaccurate.

8. Make sure that the purge fitting seals are tight so that air cannot be drawn by suction into the sensor case.

5.1 Pressure relief

R-Series sensors are available with a rupture disk installed on the case. Rupture disks are meant to vent process fluid from the sensor case in the unlikely event of a flow tube breach. Some users connect a pipeline to the rupture disk to help contain escaping process fluid. For more information about rupture disks, contact Micro Motion Customer Service.

If the sensor has a rupture disk, it should remain installed at all times as it would otherwise be necessary to re-purge the case. If the rupture disk is activated by a tube breach, the seal in the rupture disk will be broken, and the Coriolis meter should be removed from service.

The rupture disk is located as follows on the meter, and the warning sticker shown is placed next to it.

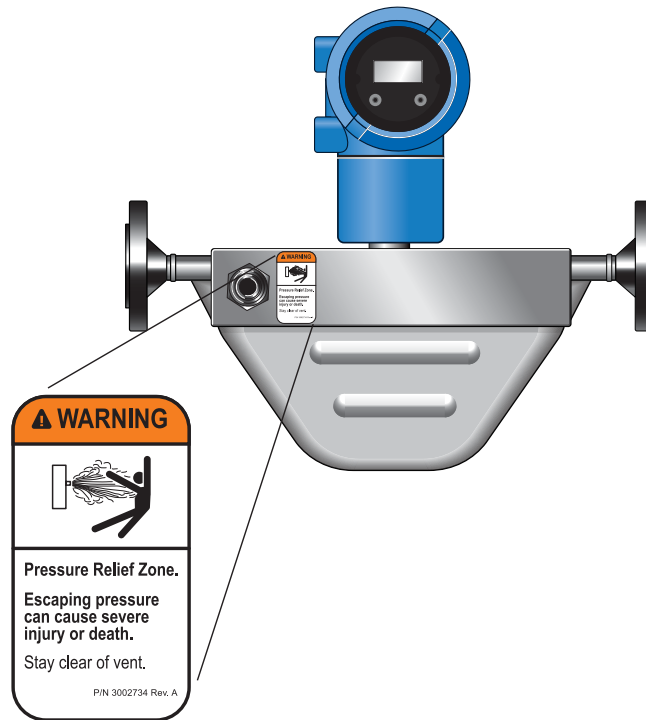

⚠ DANGER!

Stay clear of the rupture disk pressure relief area. High-pressure fluid escaping from the sensor can cause severe injury or death.

The sensor must be oriented so that personnel and equipment will not be exposed to any discharge along the pressure relief path.

Important

If a rupture disk is used, the housing can no longer assume a secondary containment function.

⚠ WARNING!

Removing the Purge Fitting, Blind Plug, or Rupture Disks compromises the Ex-i Safety Certification, the Ex-tc Safety Certification, and the IP-rating of the Coriolis meter. Any modification to the Purge Fitting, Blind Plug, or Rupture Disks must maintain a minimum of IP66/IP67 Ratings.



20002514

Rev BC

2018

Micro Motion Inc. USA

Worldwide Headquarters
7070 Winchester Circle
Boulder, Colorado USA 80301
T +1 303-527-5200
T +1 800-522-6277
F +1 303-530-8459
www.emerson.com

Micro Motion Europe

Emerson Automation Solutions
Neonstraat 1
6718 WX Ede
The Netherlands
T +31 (0) 70 413 6666
F +31 (0) 318 495 556
www.micromotion.nl

Micro Motion Asia

Emerson Automation Solutions
1 Pandan Crescent
Singapore 128461
Republic of Singapore
T +65 6777-8211
F +65 6770-8003

Micro Motion United Kingdom

Emerson Automation Solutions
Emerson Process Management Limited
Horsfield Way
Bredbury Industrial Estate
Stockport SK6 2SU U.K.
T +44 0870 240 1978
F +44 0800 966 181

Micro Motion Japan

Emerson Automation Solutions
1-2-5, Higashi Shinagawa
Shinagawa-ku
Tokyo 140-0002 Japan
T +81 3 5769-6803
F +81 3 5769-6844

©2018 Micro Motion, Inc. All rights reserved.

The Emerson logo is a trademark and service mark of Emerson Electric Co. Micro Motion, ELITE, ProLink, MVD and MVD Direct Connect marks are marks of one of the Emerson Automation Solutions family of companies. All other marks are property of their respective owners.

MICRO MOTION™



ANEXO IV

Certificados de calibración de los equipos de medición

TECNET

Grupo EZENTIS

INFORME TÉCNICO

VERIFICACIÓN DE EQUIPO
DE MEDIDA ION8650
MW-1809A327-02.

Punto de Medida
CENTRAL TENO GAS 50MW
TRAFO 1 66kV
SSEE AGUAS CLARAS
INNOCACIÓN ENERGÍA S.A.

**Gerencia Negocios de Generación,
Transmisión y Grandes Consumidores**

Santiago, Enero de 2019

INDICE

1.- OBJETIVO DE LA VERIFICACIÓN	2
2.- ANTECEDENTES GENERALES	2
3.- EQUIPAMIENTO UTILIZADO	2
4.- ACTIVIDADES DESARROLLADAS	3
5.- RESULTADOS DE LOS ENSAYOS EXIGIDOS.....	4
6.- CONCLUSIONES Y RECOMENDACIONES	4
ANEXO 1: Acta N° 1_ Cumplimiento de Características Técnicas EM.....	5
ANEXO 2: Acta N° 2_ Cumplimiento de Características Técnicas TTMM.....	7
ANEXO 3: Acta N°3_ Revisión de Equipo de Medida	9
ANEXO 4: Certificado de Verificación	11
ANEXO 5: Certificado de calibración del equipo patrón.....	15
ANEXO 6: Antecedentes de los Auditores	17

1.- OBJETIVO.

Verificación de medidor asociado al punto denominado “**CENTRAL TENO GAS 50MW**”, Barra 66kV S/E Aguas Claras, cumpliendo las disposiciones y exigencias técnicas de calidad de la medida de energía eléctrica.

2.- ANTECEDENTES GENERALES.

Como parte de la verificación del punto de medición, se realiza a petición de la empresa INERSA, la comprobación de exactitud del **Medidor de Facturación Nuevo** marca Schneider Electric, Modelo ION8650, número de serie MW-1809A327-02, ubicado en la sala eléctrica de la S/E Aguas Claras. Dicho servicio, fue ejecutado por personal especialista de TECNET S.A., señores Víctor Fernández González y Luis Aedo Manríquez, con fecha 21 de enero de 2019.

3.- INSTRUMENTACIÓN Y EQUIPAMIENTO UTILIZADO.

Para la ejecución del trabajo de verificación del medidor, se emplea el siguiente equipo:

- Patrón electrónico trifásico marca MTE, modelo PTS 3.3C, índice de clase 0.05, trazado con Estándar Primario y certificación vigente otorgado por Laboratorio Control de Instrumentos de TECNET. Ver Certificado PTS 3.3C serie 35114 en **ANEXO N°5**.

4.- ACTIVIDADES DESARROLLADAS.

El servicio proyectado consideró efectuar las siguientes actividades relevantes:

- Inspección visual de las condiciones del equipo de medida a verificar y sobre el entorno asociado a este, como también del cumplimiento las Exigencias Técnicas de Calidad del Esquema de Medida para equipos de medida, según formulario tipo denominado: Acta N° 1: Cumplimiento de Características Técnicas Equipo de Medida. **ANEXO N°1.**
- Corroborar programación del medidor: la programación del reloj, las constantes de transformación de potencial y corriente, condiciones metrologías (voltajes, tipo de conexión, etc.).
- Verificación del tipo de sincronización del clock de medidor, identificando si esta es local mediante GPS, remota en base a red Ethernet corporativa u otra, o si esta se realiza en forma manual. **La sincronización automática a través de GPS, se encuentra en proceso de instalación y habilitación.**
-
- Corroborar si el equipo de medida tiene habilitada la comunicación remota. **Se encuentra en proceso de instalación y habilitación.**
- Los parámetros antes señalados y otros, se detallarán en el “Acta N° 3: Revisión de Equipo de Medida. **ANEXO N°3.**
- Se realiza verificación o comprobación de exactitud del medidor Nuevo, marca Schneider Electric, Modelo ION8650, número de serie MW-1809A327-02, en sus cuatro cuadrantes.

La verificación se realizó tanto a las componentes activas como reactivas. Los resultados de los ensayos se muestran en el certificado de comprobación de exactitud de medidor, **ANEXO N°4.**

- Se realiza configuración del medidor según normativa.
- Se realiza Inspección visual a los TTMM, según “Acta N° 2: Cumplimiento de Características Técnicas Transformadores de Medidas. **ANEXO N°2.**

5.- RESULTADOS DE LOS ENSAYOS EXIGIDOS.

5.1) Referente a las pruebas de comprobación de exactitud.

El medidor en su módulo activo, cumple con los límites de exactitud especificados para su índice de clase, según lo establecido en la norma IEC 62053-22:2003.

El medidor en su módulo reactivo, cumple con los límites de exactitud especificados para su índice de clase, según lo establecido en la norma IEC 62053-23:2003.

5.2) Referente a los antecedentes rescatados en terreno.

Los antecedentes relacionados al equipo de medida verificado, se entregan en los formularios correspondientes y requeridos según el Documento Técnico de “*Sistemas de Medida de Energía*”, y son los recopilados teniendo a la vista el medidor en cuestión.

El equipo de medida asociado a “**CENTRAL TENO GAS 50MW, 66kV**”, es de responsabilidad de la empresa INNOVACIÓN ENERGIA S.A.

6.- CONCLUSIONES Y RECOMENDACIONES

Basados en lo expuesto en los puntos anteriores de este informe y a partir de los ensayos y mediciones realizadas al medidor marca Schneider Electric, modelo ION8650 (M8650A4C0H5E1B0A), número de serie MW-1809A327-02 y las revisiones de información perteneciente al punto de medida denominado “**CENTRAL TENO GAS 50MW**, Barra 66kV S/E Aguas Claras”, se pudo constatar que cumple con las exigencias técnicas de las medidas y las exigencias técnicas de calidad de los equipos.

Se recomienda:

- Integrar un sistema de sincronización al sistema de medida, según se indica en el **TITULO II** del DT Sistemas de Medidas.

ANEXO 1

Acta 1: Cumplimiento de Características Técnicas Equipo de Medida.

ACTA N° 1 CUMPLIMIENTO DE CARACTERÍSTICAS TÉCNICAS EM



DATOS DE PLACA DEL MEDIDOR	
MARCA	SCHNEIDER ELECTRIC
MODELO	ION8650
N° MODELO	M8650A4C0H5E1B0A
N° SERIE	MW-1809A327-02

N° AC-CT-EM	TECNET-19-0004
FECHA	21-01-2019
SUBESTACIÓN/CENTRAL	AGUAS CLARAS
PAÑO	TRANSFORMADOR 1
INSTALACIÓN	CENTRAL TENO GAS 50MW

CARACTERÍSTICAS ARTICULO 5 ANEXO TÉCNICO	CUMPLE (SI/NO)
a) Fabricación según norma IEC 60687, ANSI 12.20, NCh 2542 o posterior que las reemplace.	SI
b) Medidor de 4 cuadrantes para energía activa y reactiva con corrientes y tensiones por fase.	SI
c) Medidor del tipo estático normalizados como clase 0,2 (IEC 62053-22 y 62052-11 o posterior que las reemplace).	SI
d) Conexión de tres elementos y cuatro hilos.	SI
e) Registro de variables eléctricas en unidades de ingeniería (o constante unitaria sin provocar saturación de registro).	SI
f) Puerto de comunicación para interrogación local y remota. Para interrogación remota, dispone de al menos una puerta de comunicación ethernet para acceso de CDEC.	SI
g) Equipo de Medida conectado a núcleos de clase de precisión 0,2 (IEC 61869-2 para transformador de corriente e IEC 61869-3/5 para transformador de potencial).	SI
h) Corriente de carga máxima secundaria de al menos 10 [A] para medidores de corriente nominal de 5 [A] y de al menos 2 [A] para medidores de corriente nominal de 1 [A].	SI
i) Almacenamiento de información en períodos de integración de a lo menos 15 minutos.	SI
j) Memoria masa para el registro de al menos 12 canales, durante al menos 40 días para almacenamiento en períodos de integración de 15 minutos.	SI
k) Indicadores visuales de al menos energía acumulada y demanda máxima.	SI
l) Sincronización horaria directamente por medio de un GPS u otro medio que permita asegurar dicha sincronización con la Hora Oficial definida en NT.	SI
m) Configurado en sus constantes de razón de transformación y de multiplicación de modo tal que los datos de la medida correspondan a la energía inyectada o retirada.	SI
n) Capacidad de conservar los datos históricos ante ajustes de sincronización u otros.	SI
o) Dispone de programas que permitan la lectura y configuración local y remota.	SI
p) Autonomía en su funcionamiento con vida útil de al menos 5 años, alimentando el reloj interno, manteniendo configuración y almacenamiento de datos durante al menos 40 días por medio de una memoria no volátil.	SI
q) Capacidad para generar archivos de salida con formato exportable a planillas de cálculo de uso comercial.	SI
r) Protocolo de lectura local y remota abierto con el fin de que pueda ser integrado a PRMTE que defina la DP.	SI

RESPONSABLES

PERSONA RESPONSABLE EMPRESA AUDITORA	
NOMBRE	LUIS AEDO MANRÍQUEZ
EMPRESA	TECNET S.A.
FIRMA	

PERSONA RESPONSABLE COORDINADO	
NOMBRE	DAVID GUTIERREZ
EMPRESA	INGENIERÍA Y SERVICIOS SIGHT ELECTRIC LTDA.
FIRMA	

OBSERVACIONES

--

ANEXO 2

Acta 2: Cumplimiento de Características Técnicas Transformadores de Medidas.

ACTA N° 2 CUMPLIMIENTO DE CARACTERÍSTICAS TÉCNICAS TRANSFORMADOR DE MEDIDAS



N° AC-CT-TM	TECNET-19-0004
FECHA	21-01-2019
SUBESTACIÓN/CENTRAL	AGUAS CLARAS
PAÑO	TRANSFORMADOR 1
INSTALACIÓN	CENTRAL TENO GAS 50MW

DATOS DE PLACA DEL TC	
MARCA	TAIKAI
N° SERIE FASE A	180082 A
N° SERIE FASE B	180082 B
N° SERIE FASE C	180082 C
Corriente Primaria	600-1200
Corriente Secundaria	5

DATOS DE PLACA DEL TP	
MARCA	SIEYUAN
N° SERIE FASE A	42182793
N° SERIE FASE B	42182794
N° SERIE FASE C	42182795
Tensión Primaria	66000
Tensión Secundaria	110

ECM (SI/NO)	NO
-------------	----

RAZÓN CONECTADA	
TP	600,0
TC	120,0

CARACTERÍSTICAS ARTÍCULO 6 ANEXO TÉCNICO		CUMPLE (SI/NO)	
		TC	TP
a)	Cumple con la última revisión de la norma IEC 60044-1 (Ex 185) para el TC e IEC 60186 para el TP o posterior que las reemplace. Para equipo compacto de medida, clase de precisión 0,3 ANSI C 12.	SI	SI
b)	Clase de precisión igual o mejor que 0,2 según norma IEC 61869-2 para el TC e IEC 61869-3/5 para TP o posterior que las reemplace. Para equipo compacto de medida, clase de precisión 0,3 ANSI C 12.	SI	SI
c)	Conexión corresponde a un Sistema de Medida de tres elementos.	SI	SI
d)	Factor de saturación FS, tiene valor igual o menor a cinco veces la corriente nominal.	S/I	N/A
e)	Protocolos de Verificación en Fábrica con registros de curvas de errores de razón y ángulo de fase de corriente secundaria.	SI	SI
f)	La corriente primaria de trabajo en condiciones normales, debe encontrarse entre 35 y 100 [%] de la corriente nominal primaria	S/I	N/A
g)	La suma de las potencias de consumo de los Equipos de Medida u otros elementos instalados en el secundario del TC debe ser permanentemente menor o igual al 100 % de la potencia de precisión o burden del transformador. La suma de las potencias de consumo no deben superar el burden nominal del transformador.	S/I	S/I
h)	Tensión primaria de trabajo del transformador de medida corresponde con la tensión del punto de medida.	N/A	S/I
i)	Datos de la placas de características está visible y es de fácil lectura.	SI	SI
j)	Marcas de cables visibles e identificables.	SI	SI
k)	Dispone de Terminal de puesta a tierra.	SI	SI
l)	Dispone de Caja de conexión de tomas en los enrollamientos secundarios	SI	SI

*Para los casos de los literales d) y g), en caso de no poseer la información, la empresa auditora deberá completar con S/I, detallando la justificación respectiva en campo de observaciones.

RESPONSABLES

EMPRESA COORDINADA		EMPRESA AUDITORA	EMPRESA
NOMBRE	DAVID GUTIERREZ	LUIS AEDO MANRÍQUEZ	
EMPRESA	INGENIERÍA Y SERVICIOS SIGHT ELECTRIC LTDA.	TECNET S.A.	
FIRMA			

OBSERVACIONES

- d) INFORMACIÓN NO DISPONIBLE EN EL PROTOCOLO DE VERIFICACIÓN DEL ECM.
- g) NO SE REALIZARON MEDICIONES DE BURDEN.
- f) y h) SISTEMA DE MEDIDA NUEVO, NO SE ENCUENTRA EN SERVICIO.

ANEXO 3

Acta 3: Revisión de Equipo de Medida.

ACTA N° 3 REVISIÓN DE EQUIPO DE MEDIDA



N° AR-EM	TECNET-19-0004	EMPRESA COORDINADA	Innovacion Energia S.A
FECHA	21-01-2019		
SUBESTACIÓN/CENTRAL	AGUAS CLARAS		
PAÑO	TRANSFORMADOR 1		
INSTALACIÓN	CENTRAL TENO GAS 50MW		

DATOS DE PLACA DEL MEDIDOR			
MARCA	SCHNEIDER ELECTRIC	N° ELEM	3
MODELO	ION8650	CLASE	0.2%
N° MODELO	M8650A4C0H5E1B0A	V NOMINAL	57 - 277 V L-N
N° SERIE	MW-1809A327-02	CORRIENTE	5(20)A

REFERENCIA GEOGRÁFICA	
CIUDAD	CURICO
COMUNA	TENO
COORD. NORTE	S 34°52'4.88"
COORD. ESTE	O 71° 8'36.13"

CONFIGURACIÓN					
ITEM				VALOR	
CONFIGURACIÓN	CONFIGURACIÓN DE ALAMBRADO (Elementos / Hilos)				3E-4H
	TENSIÓN NOMINAL				57 - 277 V L-N
	CORRIENTE MÁXIMA				5(20)A
	TENSIÓN PRIMARIA				66000
	TENSIÓN SECUNDARIA				110
	CORRIENTE PRIMARIA				600
	CORRIENTE SECUNDARIA				5
	SINCRONIZACIÓN RELOJ (INTERNA/EXTERNA (GPS/RED))				INTERNA
	PERFIL DE CARGA	TOTAL DE CANALES			
TOTAL DE CANALES CONFIGURADOS				12	
DURACIÓN DEL INTERVALO				15	
DÍAS DE ALMACENAMIENTO				95	
		VARIABLE	N° CANAL	VARIABLE	N° CANAL
		kWh del	1-1	Tensión C-A prom.	1-7
		kVarh del	1-2	Corr. A prom.	1-8
		kWh rec	1-3	Corr. B prom.	1-9
		kVarh rec	1-4	Corr. C prom.	1-10
		Tensión A-B prom.	1-5	Promedio Tensiones	1-11
		Tensión B-C prom.	1-6	Promedio Corr.	1-12

ESQUEMA	CUMPLE
BLOCK DE PRUEBA	SI
BORNERAS	SI
SECCIÓN CONDUCTOR I	SI
SECCIÓN CONDUCTOR V	SI
MARCAJE ALAMBRADO	SI
PUERTA ETHERNET	SI

INSPECCIÓN VISUAL	ESTADO
MONTADO RÍGIDAMENTE	BUENO
CUBIERTA EN BUEN ESTADO	BUENO
DISPLAY	BUENO
BOTONES DE NAVEGACIÓN	BUENO
TERMINALES	BUENO
ALAMBRADO	BUENO
CABLES COMUNICACIÓN	BUENO
TIERRA CARCAZA MEDIDOR	BUENO
TIERRA GABINETE	BUENO

ALIM. DE MEDIDOR	VALOR
AUTOALIMENTADO	-
ALIMENTACION EXTERNA	110,0Vdc

VALIDACIÓN OTROS	CUMPLE
PRIMER INTERVALO DEL DÍA CORRESPONDE AL REGISTRO DEL PERIODO 00:15	S/I
PERIODOS DE DATA IGUAL A PERIODOS DE TIEMPO TRANSCURRIDO	S/I
CANALES DIRECTOS (DELIVERED) REGISTRAN LOS RETIROS DEL SISTEMA	S/I
CANALES REVERSOS (RECEIVED) REGISTRAN LAS INYECCIONES AL SISTEMA	S/I

SELLOS		
UBICACIÓN	ENCONTRADO	DEJADO
CUBIERTA	*	Tecnet 197706
RESET	*	Tecnet 197717

PERSONA RESPONSABLE EMPRESA AUDITORA	
NOMBRE	LUIS AEDO MANRÍQUEZ
EMPRESA	TECNET S.A.
FIRMA	

PERSONA RESPONSABLE COORDINADO	
NOMBRE	DAVID GUTIERREZ
EMPRESA	INGENIERÍA Y SERVICIOS SIGHT ELECTRIC LTDA.
FIRMA	

OBSERVACIONES
- SISTEMA DE MEDIDA SIN SINCRONIZACIÓN HORARIA AUTOMÁTICA.
- MEDIDOR ION8650 SERIE MW-1809A327-02, FUE VERIFICADO TANTO EN LAS COMPONENTES ACTIVAS COMO REACTIVAS
- MEDIDOR CUMPLE CON CON LOS LÍMITES DE EXACTITUD, EN SU MODULO ACTIVO Y REACTIVO.

ANEXO 4

Certificado de Verificación.

INFORME DE ENSAYO
CERTIFICADO DE COMPROBACIÓN DE EXACTITUD DE MEDIDOR.

Tecnet S. A., Organismo de Comprobación de Exactitud de Medidores de Energía Eléctrica, según resoluciones exentas SEC N° 219 del 19 de Febrero de 2001.

Certificado N° CVM-TD01288 - 16 - 00

1. ANTECEDENTES DEL CLIENTE.

Razón Social	VITUCO SpA.
Dirección	AVDA. EL BOSQUE CENTRAL 92 PISO 6, LAS CONDES.
Ciudad	SANTIAGO
Orden de Compra	41415152
Fecha de Solicitud	07-01-2019

2. CARACTERÍSTICAS MEDIDOR DE ENERGÍA.

Marca	Schneider Electric
Modelo	M8650A4COH5E1B0A
N° de Serie	MW-1803A543-02
Tensión Nominal	3 x 57 - 277 V L-N
Corriente	3 x 5(20) A
Frecuencia	50 Hz.
Constante	1,8 Wh/Imp
Año Fabricación	2018
Clase Exactitud Activo	± 0,2s %
Clase Exactitud Reactivo	± 2%
Constante Lectura	1
Lectura Dejada Activo	0,000 kWh
Lectura Dejada Reactivo	0,000 kVARh
Estado	Medidor Nuevo

3. OBSERVACIONES.

El equipo patrón utilizado cuenta con su Certificado de Calibración vigente y ha sido calibrado y trazado al Sistema Internacional de Unidades (SI).

Este certificado sólo puede ser difundido íntegro y sin modificaciones ni enmiendas.

Este certificado es válido sólo con firma y timbre.

Medidor se entrega con logo y sello TECNET.

Responsables de las pruebas de comprobación:

Luis Aedo M.
12.310.241-8

16-01-2019
Fecha



Timbre
Página 1 de 3

4. CONDICIONES DE LA COMPROBACIÓN DE EXACTITUD.

4.1. LUGAR DE ENSAYO.

Lugar	Laboratorio TECNET Santiago.
Fecha ejecución	16.01.2019
Realizó	Luis Aedo M.
Procedimiento aplicado	PR-GM-17, IN-GM-04

4.2. CARACTERÍSTICAS PATRÓN.

Marca	MTE
Modelo	PTS 3,3 C
Clase	± 0.05 %
N° serie	35114

4.3. CONDICIÓN DE MEDIDA.

Tipo de Medida	Directa
Temperatura	Ambiente
Humedad	Ambiente
Voltaje Nominal	220 (V)
Corriente Nominal (In)	5 (A)
Frecuencia	50 Hz

4.4. TRATAMIENTO SELLOS MEDIDOR.

	Encontrados.	Dejados.
Cubierta	*	Tecnet 197739
Bornes	*	
Reset	*	Tecnet 197749

4.5. PRUEBAS DE COMPROBACIÓN EXACTITUD.

La interpretación de los resultados de las pruebas se realizaron tomando como referencia los requisitos establecidos en las normas técnicas de medidores vigentes.

El error relativo calculado está referido a la energía activa o reactiva, según corresponda.

A continuación se presentan los resultados de las pruebas realizadas para comprobar la exactitud del medidor de energía indentificado en punto 2.



Página 2 de 3

9

4.5.1. TABLA ERRORES MODO ENERGÍA ACTIVA.

PRUEBAS TRIFASICAS A VOLTAJE NOMINAL							
Elemento	Carga %	FP	Error %				Limite Norma %
			Modo Directo		Modo Inverso		
			Inicial	Final	Inicial	Final	
1-2-3	100	1	0,009	0,009	0,007	0,007	± 0,2
1-2-3	100	0,5	0,029	0,029	0,025	0,025	± 0,3
1-2-3	10	1	0,014	0,014	0,011	0,011	± 0,2

PRUEBAS POR ELEMENTO A VOLTAJE NOMINAL							
Elemento	Carga %	FP	Error %				Limite Norma %
			Modo Directo		Modo Inverso		
			Inicial	Final	Inicial	Final	
1	100	1	-0,009	-0,009	-0,011	-0,011	± 0,3
2	100	1	0,018	0,018	0,020	0,020	± 0,3
3	100	1	0,012	0,012	0,012	0,012	± 0,3
1	100	0,5	-0,010	-0,010	-0,008	-0,008	± 0,4
2	100	0,5	0,033	0,033	0,033	0,033	± 0,4
3	100	0,5	0,052	0,052	0,050	0,050	± 0,4

4.5.2. TABLA ERRORES CON ENERGÍA REACTIVA.

PRUEBAS TRIFASICAS A VOLTAJE NOMINAL							
Elemento	Carga %	SenØ	Error %				Limite Norma %
			Modo Directo		Modo Inverso		
			Inicial	Final	Inicial	Final	
1-2-3	100	1	-0,004	-0,004	-0,007	-0,007	± 2,0
1-2-3	100	0,5	0,014	0,014	-0,028	-0,028	± 2,0
1-2-3	10	1	0,000	0,000	-0,005	-0,005	± 2,0

PRUEBAS POR ELEMENTO A VOLTAJE NOMINAL							
Elemento	Carga %	SenØ	Error %				Limite Norma %
			Modo Directo		Modo Inverso		
			Inicial	Final	Inicial	Final	
1	100	1	0,000	0,000	-0,003	-0,003	± 3,0
2	100	1	-0,012	-0,012	-0,011	-0,011	± 3,0
3	100	1	-0,004	-0,004	-0,005	-0,005	± 3,0
1	100	0,5	0,017	0,017	-0,016	-0,016	± 3,0
2	100	0,5	0,027	0,027	-0,056	-0,056	± 3,0
3	100	0,5	-0,010	-0,010	0,000	0,000	± 3,0

4.6. PRUEBA DE ARRANQUE.

El medidor, para el ensayo de arranque, cumple con lo establecido en la norma IEC 62053-22.

4.7. PRUEBA DE MARCHA EN VACÍO.

El medidor, para el ensayo de marcha en vacío, cumple con lo establecido en la norma IEC 62053-22.

5. CONCLUSIONES.

Tecnet S.A. certifica la exactitud de la medida del medidor de energía sujeto a pruebas, según los errores indicados en este Informe de Ensayo.

El medidor en su módulo Activo, Cumple con los límites de exactitud especificados para su clase, según lo establecido en la norma IEC 62053-22 :2003.

El medidor en su módulo Reactivo, Cumple con los límites de exactitud especificados para su clase, según lo establecido en la norma IEC 62053-23 :2003.

El medidor en su placa de características, cumple con los requisitos de marcado, según lo establecido en la norma IEC 62052-11 :2003.



Timbre
Página 3 de 3

ANEXO 5

Certificado de calibración del equipo patrón.

INFORME VERIFICACIÓN DE INSTRUMENTO

VERIFICACIÓN EXACTITUD EQUIPO O INSTRUMENTO DE MEDIDA

TECNET S.A., Departamento Medición y Laboratorio.

Informe N° LCI- 4397

IDENTIFICACIÓN INSTRUMENTO	
Tipo Equipo/Instrumento	Patrón de Energía
Marca	MTE
Modelo	PTS 3.3C
N° de Serie	35114
Estado	Usado

ANTECEDENTES DEL CLIENTE	
Empresa	TECNET
Zonal	Of. Central
Ciudad	Santiago
Depto/Unidad	Medición

LUGAR DE ENSAYO	
Lugar de Ensayo	Laboratorio Instrumentación Oficina Central
Fecha de Ensayo	04-06-2018
Realizó	Valeska Madariaga G

CONDICIÓN DE MEDIDA	
Procedimiento Usado	PR-GM-24
Voltaje Nominal (Vn)	220 V
Corriente Nominal (In)	N/A
Frecuencia	50 Hz
Temperatura °C / Humedad %	22,52/30,28

CARACTERÍSTICAS PATRON	
Marca	MTE
Modelo	PTS 3.3C
Clase	± 0,05%
N° Serie	37311
Fecha próxima Calibración	26-07-2018

DATOS DE VERIFICACIÓN

TAPS: 220V / 10A / 50Hz									
Corriente (A) FP=1					Corriente (A) FP=0,5				
Secuencia	Corriente Patrón	Error %	Rango	Aprueba (A) Rechaza (R)	Secuencia	Corriente Patrón	Error %	Rango	Aprueba (A) Rechaza (R)
1°	0,1	0,010	± 0,05%	A	6°	5	-0,017	± 0,05%	A
2°	0,5	-0,003	± 0,05%	A	7°	10	0,007	± 0,05%	A
3°	1	0,000	± 0,05%	A					
4°	5	0,002	± 0,05%	A					
5°	10	0,000	± 0,05%	A					

TAPS: 220V / 100A / 50Hz									
Corriente (A) FP=1					Corriente (A) FP=0,5				
Secuencia	Corriente Patrón	Error %	Rango	Aprueba (A) Rechaza (R)	Secuencia	Corriente Patrón	Error %	Rango	Aprueba (A) Rechaza (R)
1°	1	0,000	± 0,05%	A	7°	5	-0,009	± 0,05%	A
2°	5	0,000	± 0,05%	A	8°	10	-0,004	± 0,05%	A
3°	10	-0,001	± 0,05%	A	9°	20	-0,021	± 0,05%	A
4°	20	-0,016	± 0,05%	A	10°	50	-0,026	± 0,05%	A
5°	50	-0,012	± 0,05%	A	11°	100	-0,020	± 0,05%	A
6°	100	-0,011	± 0,05%	A					

Conclusión.

El instrumento cumple con los rangos de especificaciones establecidos por el fabricante.

Observaciones.

El equipo patrón utilizado cuenta con su Certificado de Verificación y/o Calibración vigente y trazado al Sistema Internacional de Unidades (SI).

Este informe sólo puede ser difundido íntegro y sin modificaciones ni enmiendas.

El equipo o instrumento se entrega con su etiqueta de Control Instrumentos de Medición adosada, con la "fecha verificación" y "próxima verificación" que se indican en este informe.

Frente a una falla o alteración no intencionada de este instrumento, acontecida durante su operación entre fechas o periodicidad de su verificación y/o calibración, se recomienda realizar una verificación o chequeo de sus condiciones metrológicas previo a su reutilización.

Garantía de la Verificación.

Los resultados contenidos en el presente informe se refieren al momento y condiciones en que se realizaron las mediciones. Tecnet S.A. no se responsabiliza de los perjuicios que puedan derivarse del uso inadecuado de la información aquí contenida así como del instrumento verificado.

Próximo Control: 04-06-2019



Responsable Valeska Madariaga G.



Timbre

ANEXO 6

Antecedentes de los Auditores.

Antecedentes de los Auditores:

- Luis Aedo Manríquez (Jefe Medición Avanzada), Rut: 13.310.241-8.
- Víctor Fernández González. (Asistente Sénior Medición Avanzada), Rut: 12.872.118-5.



PROTOCOLO DE PRUEBA
TRANSFORMADORES DE CORRIENTE

IDENTIFICACIÓN Y CARACTERÍSTICAS

PROYECTO	ENLASA TENO TRANSFORMADOR DE PODER 55 MVA TAIKAI	Nº PROTOCOLO	1 DE 2
NOMBRE DE EQUIPO	TRANSFORMADORES DE CORRIENTE HV	T. AMBIENTE	25°C
Nº SERIE POLO	A, B, C	HUMEDAD	40,0%
FABRICACION	TAIKAI	FECHA	29-nov-18
RAZONES	600 /5-5-5 (A)	COIL :	1S1-1S2/2S1-2S2/3S1-3S2/4S1-4S2
INSTRUMENTO	CPC - 100 OMICRON, METER MAN, MEGGER MIT 520	TIPO :	LRB-66 /LRB-66 / LR66
		PRESICION:	0,2-5P20-5P20 0,5

RESISTENCIA. DE AISLACION (GΩ)				RESISTENCIA OHMICA (mΩ)		
VOLTAJE DE PRUEBA 500 (V)				DESCRIPCION	PUNTOS	VALOR
DESCRIPCION	PUNTOS	0,5 MIN	1 MIN			
TC A	1S1-2S1-3S1/TIERRA	30,5	37,1	POLO A	1S1 - 1S2	229,7
	1S1-2S1	27,8	35,6		2S1 - 2S2	284,2
	1S1-3S1	34,7	44,6		3S1 - 3S2	282,0
	2S1-3S1	29,3	38,8			
TC B	1S1-2S1-3S1/TIERRA	29,7	36,6	POLO B	1S1 - 1S2	156,8
	1S1-2S1	29,5	31,7		2S1 - 2S2	283,1
	1S1-3S1	39,2	48		3S1 - 3S2	281,1
	1S1-4S1	31,1	37		4S1 - 4S2	162,8
	2S1-3S1	27,4	34,5			
	2S1-4S1	35,2	44,1			
TC C	1S1-2S1-3S1/TIERRA	24,1	28	POLO C	1S1 - 1S2	178,1
	1S1-2S1	26,1	32,5		2S1 - 2S2	283,6
	1S1-3S1	33,9	40,3		3S1 - 3S2	283,0
	2S1-3S1	27,9	33,9			

RAZON TRANSFORMACION, ERROR, ANGULO Y POLARIDAD Iaplicad= 300 A

FASE	PUNTOS	RAZON	ANGULO	ERROR	POLARIDAD
FASE A	P1 / 1S1 -	600:4,9962	0,05	-0,08%	CORRECTA
	P1 / 2S1 -	600:4,9881	0,07	-0,24%	CORRECTA
	P1 / 3S1 -	600:4,9867	0,09	-0,27%	CORRECTA
FASE B	P1 / 1S1 -	600:5,0003	0,16	0,01%	CORRECTA
	P1 / 2S1 -	600:4,9882	0,11	-0,24%	CORRECTA
	P1 / 3S1 -	600:4,9883	0,11	-0,23%	CORRECTA
	P1 / 4S1 -	600:5,0046	0,18	0,09%	CORRECTA
FASE C	P1 / 1S1 -	600:5,0006	0,09	0,01%	CORRECTA
	P1 / 2S1 -	600:4,9872	0,14	-0,26%	CORRECTA
	P1 / 3S1 -	600:4,9856	0,16	-0,29%	CORRECTA

OBSERVACIONES

- * TRANSFORMADORES DE CORRIENTE EN BUENAS CONDICIONES ELECTRICAS DE AISLAMIENTO
- * PARAMETROS DE RAZON DE TRANSFORMACION SEGÚN INDICACIONES DEL FABRICANTE
- * TRANSFORMADORES DE CORRIENTE EN BUENAS CONDCIONES ELECTRICAS PARA SER PUESTOS EN SERVICIO
- * ERRORES DE RELACION DE TRANSFORMACION SEGÚN PRESICIONES DE LOS DEVANDOS INDICADOS POR EL FABRICANTE EN PLACA

REALIZADO POR

NOMBRE: JUAN L. MEDINA ROA
FECHA: 29-11-2018

FIRMA

REVISADO POR

NOMBRE: HUGO E. OPAZO MORA
FECHA: 29-11-2018

FIRMA

Transformador de tensión capacitivo

CERTIFICACIÓN DE PRODUCTO



CÓDIGO DE FABRICACIÓN 06820006

MODELO DE PRODUCTO: TYD66/ $\sqrt{3}$ -0.02W3

RELACIÓN DE TRANSFORMACIÓN NOMINAL:

66000/ $\sqrt{3}$ /110/ $\sqrt{3}$ /110/ $\sqrt{3}$ /110/3

CLASE DE PRECISIÓN: 0.2/0.5 /3P

Capacitor No. 41181455

Nº DE PRODUCTO: 42182793

JIANGSU SIEYUAN HERTZ ALTO VOLTAJE FÁBRICA

DE APARATOS ELÉCTRICOS DE LA REPÚBLICA

POPULAR CHINA

ESPECIFICACIÓN Y PARÁMETRO TÉCNICO

Código estándar: IEC61869—5

Número de fases: Monofásico

Tipo: Inmerso en aceite , intemperie

Voltaje primario nominal: $\underline{66/\sqrt{3}}$ kV

Frecuencia nominal: 50 Hz

Devanado secundario: Tensión nominal $\underline{110 / \sqrt{3} V}$ Capacidad nominal 60 VA clase de precisión 0.2

Devanado secundario: Tensión nominal $\underline{110 / \sqrt{3} V}$ Capacidad nominal 160 VA clase de precisión 0.5

Devanado secundario: Tensión nominal $\underline{110 / 3 V}$ Capacidad nominal 320 VA clase de precisión 3P

capacitancia nominal: 0.02 μF , C1 0.02739 μF , C2 0.07411 μF

factor de tensión nominal: 1,2 / continua; 1.5/30s.

Resultados de pruebas

1. Prueba de Capacitor

1.1 Prueba de hermeticidad: No fuga

1.2 Tensión soportada de frecuencia Industrial, 160 kV 1min, Probado.

1.3 Tensión soportada de frecuencia Industrial de terminal de baja tensión 4 kV, 1 min, Probado.

1.4 Capacitancia, factor de pérdida dieléctrica, descargas parciales baja la tensión nominal

Celda de capacitor	capacitancia	$\tan \delta$ factor de pérdida dieléctrica
C	0.01982	0.000426
C1	0.02692	
C2	0.07494	

1.5 Medición de prueba de descarga parcial

Tensión previa 128 kV

Voltaje de medición 87 kV, 5min, La evidente de descarga es de 5 pC

Voltaje de medición 50 kV, La evidente de descarga es de 2 pC

2. Prueba de celda electromagnética

2.1 Prueba de hermeticidad: No fuga_.

2.2 Señal para terminal de salida: Correcto_.

2.3 Medición de resistencia de aislamiento: (temperatura del ambiente 28 °C, Humedad relativa 51 %)

Devanado secundario , Devanado residual y a tierra: > 2000 MΩ,

Terminal de puesta a tierra de celda electromagnética a devanado secundario , Devanado de tensión residual y a tierra: > 2000 MΩ.

2.4 Tensión soportada de inducción de devanado primario de transformador de media tensión 45.33kV, frecuencia 150Hz, 40s, probado.

2.5 Tensión soportada de inducción a tierra del lado de baja tensión de devanado primario de transformador de media tensión y devanado de reactor de compensación 4.61kV, frecuencia 150Hz, 40s, probado.

2.6 Tensión soportada de frecuencia industrial de Devanado secundario , Devanado residual y a tierra 3 kV, 1 min, probado.

2.7 Frecuencia tensión soportada en corte tiempo en el lado de puesta a tierra de transformador (E): 3kV (RMS), 1min.

2.8 Medición de la resistencia DC: (temperatura del ambiente 28 °C)

1a1n 0.0317 Ω, 2a2n 0.0600 Ω, dadn 0.0869 Ω.

2.9 Prueba del aceite de transformador: (NO. I-30°C)

Voltaje de ruptura \geq 50 kV.

Factor de disipación dieléctrica: $t=90^\circ\text{C}$ $\tan \delta \leq 0.005$

Contenido de humedad 12 mg/L

Análisis de cromatografía de gases

Unidad: $\mu\text{L/L}$

H ₂	CO	CO ₂	CH ₄	C ₂ H ₆	C ₂ H ₄	C ₂ H ₂	C1+C2
0	3	297	1.3	0	0	0	1.3

2.10 Prueba de la característica de excitación: Devanado residual sin amortiguador

devanado secundario 36.6V I= 2.56 A, P= 92.5 W

devanado secundario 55V I= 3.83 A, P= 206.6 W

Nota: Cuando hacen la prueba de tensión soportada de inducción y prueba sin carga, los pararrayos y amortiguadores deben ser desconectados, también transformadores intermedios y capacitores.

3、Prueba de la desviación después del ensamblaje

Regular el modo de conexión de devanado XT-MO-GD-L3L4-L1							
Clase de precesión de terminal de la salida	U_n (%)	Carga (VA) $\cos \Phi = 0.8$	f (%)	δ (')	Carga (VA) $\cos \Phi = 0.8$	f (%)	δ (')
1a 1n 0.2	80	1a 1n 60 2a 2n 160	-0.08	+7	1a 1n 15 2a 2n 0	+0.16	+1
	100		-0.08	+7		+0.16	+1
	120		-0.08	+7		+0.16	+1
2a 2n 0.5	80	1a 1n 60 2a 2n 160	-0.20	+14	1a 1n 0 2a 2n 40	+0.15	+4
	100		-0.20	+14		+0.15	+4
	120		-0.20	+14		+0.15	+4
da dn 3P	2	1a 1n 60 2a 2n 160 da dn 320	-2.70	+90	1a 1n 0 2a 2n 0 da dn 80	-0.40	+34
	5		-2.80	+86		-0.50	+28
	100		-2.85	+80		-0.55	+22
	150		-2.85	+84		-0.55	+24

4、resonancia ferromagnética prueba Probado.

Conclusión

Este producto es probado con los requisitos de IEC61869—5, permitido para salir

Editor: 孙晓燕

Aprobado por: 刘培富

Verificado por: 彭勇

Fecha: 2018-09-07



Transformador de tensión capacitivo

CERTIFICACIÓN DE PRODUCTO



CÓDIGO DE FABRICACIÓN 06820006

MODELO DE PRODUCTO: TYD66/ $\sqrt{3}$ -0.02W3

RELACIÓN DE TRANSFORMACIÓN NOMINAL:

66000/ $\sqrt{3}$ /110/ $\sqrt{3}$ /110/ $\sqrt{3}$ /110/3

CLASE DE PRECISIÓN: 0.2/0.5 /3P

Capacitor No. 41182584

Nº DE PRODUCTO: 42182794

**JIANGSU SIEYUAN HERTZ ALTO VOLTAJE FÁBRICA
DE APARATOS ELÉCTRICOS DE LA REPÚBLICA
POPULAR CHINA**

ESPECIFICACIÓN Y PARÁMETRO TÉCNICO

Código estándar: IEC61869—5

Número de fases: Monofásico

Tipo: Inmerso en aceite , intemperie

Voltaje primario nominal: $\frac{66}{\sqrt{3}}$ kV

Frecuencia nominal: 50 Hz

Devanado secundario: Tensión nominal $\frac{110}{\sqrt{3}}$ V Capacidad nominal 60 VA clase de precisión 0.2

Devanado secundario: Tensión nominal $\frac{110}{\sqrt{3}}$ V Capacidad nominal 160 VA clase de precisión 0.5

Devanado secundario: Tensión nominal $\frac{110}{3}$ V Capacidad nominal 320 VA clase de precisión 3P

capacitancia nominal: 0.02 μ F, C1 0.02739 μ F, C2 0.07411 μ F

factor de tensión nominal: 1,2 / continua; 1.5/30s.

Resultados de pruebas

1. Prueba de Capacitor

1.1 Prueba de hermeticidad: No fuga

1.2 Tensión soportada de frecuencia Industrial, 160 kV 1min, Probado.

1.3 Tensión soportada de frecuencia Industrial de terminal de baja tensión 4 kV, 1 min, Probado.

1.4 Capacitancia, factor de pérdida dieléctrica, descargas parciales baja la tensión nominal

Celda de capacitor	capacitancia	$\tan \delta$ factor de pérdida dieléctrica
C	0.01982	0.000485
C1	0.02703	
C2	0.07392	

1.5 Medición de prueba de descarga parcial

Tensión previa 128 kV

Voltaje de medición 87 kV, 5min, La evidente de descarga es de 5 pC

Voltaje de medición 50 kV, La evidente de descarga es de 2 pC

2. Prueba de celda electromagnética

2.1 Prueba de hermeticidad: No fuga_.

2.2 Señal para terminal de salida: Correcto_.

2.3 Medición de resistencia de aislamiento: (temperatura del ambiente 28 °C, Humedad relativa 51 %)

Devanado secundario , Devanado residual y a tierra: > 2000 MΩ,

Terminal de puesta a tierra de celda electromagnetic a devanado secundario , Devanado de tensión residual y a tierra: > 2000 MΩ.

2.4 Tensión soportada de inducción de devanado primario de transformador de media tensión 45.33kV, frecuencia 150Hz, 40s, probado.

2.5 Tensión soportada de inducción a tierra del lado de baja tensión de devanado primario de transformador de media tensión y devanado de reactor de compensación 4.61kV, frecuencia 150Hz, 40s, probado.

2.6 Tensión soportada de frecuencia industrial de Devanado secundario , Devanado residual y a tierra 3 kV, 1 min, probado.

2.7 Frecuencia tensión soportada en corte tiempo en el lado de puesta a tierra de transformador (E): 3kV (RMS), 1min.

2.8 Medición de la resistencia DC: (temperatura del ambiente 28 °C)

1a1n 0.0312 Ω, 2a2n 0.0610 Ω, dadn 0.0866 Ω.

2.9 Prueba del aceite de transformador: (NO. I-30°C)

Voltaje de ruptura \geq 50 kV.

Factor de disipación dieléctrica: $t=90^\circ\text{C}$ $\tan \delta \leq 0.005$

Contenido de humedad 11 mg/L

Análisis de cromatografía de gases

Unidad: $\mu\text{L/L}$

H ₂	CO	CO ₂	CH ₄	C ₂ H ₆	C ₂ H ₄	C ₂ H ₂	C1+C2
0	11	200	1.5	0	0	0	1.5

2.10 Prueba de la característica de excitación: Devanado residual sin amortiguador

devanado secundario 36.6V I= 2.59 A, P= 92.1 W

devanado secundario 55V I= 3.93 A, P= 204.4 W

Nota: Cuando hacen la prueba de tensión soportada de inducción y prueba sin carga, los pararrayos y amortiguadores deben ser desconectados, también transformadores intermedios y capacitores.

3、Prueba de la desviación después del ensamblaje

Regular el modo de conexión de devanado XT-DF-BA-L4L3-L1							
Clase de precesión de terminal de la salida	U_n (%)	Carga (VA) COS Φ =0.8	f (%)	δ (')	Carga (VA) COS Φ =0.8	f (%)	δ (')
1a 1n 0.2	80	1a 1n 60 2a 2n 160	-0.10	+6	1a 1n 15 2a 2n 0	+0.14	0
	100		-0.10	+6		+0.14	0
	120		-0.10	+6		+0.14	0
2a 2n 0.5	80	1a 1n 60 2a 2n 160	-0.20	+12	1a 1n 0 2a 2n 40	+0.15	+4
	100		-0.20	+12		+0.15	+4
	120		-0.20	+12		+0.15	+4
da dn 3P	2	1a 1n 60 2a 2n 160 da dn 320	-2.40	+78	1a 1n 0 2a 2n 0 da dn 80	-0.35	+32
	5		-2.50	+72		-0.40	+28
	100		-2.60	+64		-0.50	+20
	150		-2.65	+66		-0.50	+22

4、resonancia ferromagnética prueba Probado.

Conclusión

Este producto es probado con los requisitos de IEC61869—5, permitido para salir.

Editor: 孙晓燕

Aprobado por: 刘培富

Verificado por: 彭勇

Fecha: 2018-09-07



Transformador de tensión capacitivo

CERTIFICACIÓN DE PRODUCTO



CÓDIGO DE FABRICACIÓN 06820006

MODELO DE PRODUCTO: TYD66/ $\sqrt{3}$ -0.02W3

RELACIÓN DE TRANSFORMACIÓN NOMINAL:

66000/ $\sqrt{3}$ / 110/ $\sqrt{3}$ / 110/ $\sqrt{3}$ / 110/3

CLASE DE PRECISIÓN: 0.2/0.5 /3P

Capacitor No. 41181458

Nº DE PRODUCTO: 42182795

JIANGSU SIEYUAN HERTZ ALTO VOLTAJE FÁBRICA

DE APARATOS ELÉCTRICOS DE LA REPÚBLICA

POPULAR CHINA

ESPECIFICACIÓN Y PARÁMETRO TÉCNICO

Código estándar: IEC61869—5

Número de fases: Monofásico

Tipo: Inmerso en aceite , intemperie

Voltaje primario nominal: $\frac{66}{\sqrt{3}}$ kV

Frecuencia nominal: 50 Hz

Devanado secundario: Tensión nominal $\frac{110}{\sqrt{3}}$ V Capacidad nominal 60 VA clase de precisión 0.2

Devanado secundario: Tensión nominal $\frac{110}{\sqrt{3}}$ V Capacidad nominal 160 VA clase de precisión 0.5

Devanado secundario: Tensión nominal $\frac{110}{3}$ V Capacidad nominal 320 VA clase de precisión 3P

capacitancia nominal: 0.02 μ F, C1 0.02739 μ F, C2 0.07411 μ F

factor de tensión nominal: 1,2 / continua; 1.5/30s.

Resultados de pruebas

1. Prueba de Capacitor

1.1 Prueba de hermeticidad: No fuga

1.2 Tensión soportada de frecuencia Industrial, 160 kV 1min, Probado.

1.3 Tensión soportada de frecuencia Industrial de terminal de baja tensión 4 kV, 1 min, Probado.

1.4 Capacitancia, factor de pérdida dieléctrica, descargas parciales baja la tensión nominal

Celda de capacitor	capacitancia	$\tan \delta$ factor de pérdida dieléctrica
C	0.01987	0.000400
C1	0.02699	
C2	0.07496	

1.5 Medición de prueba de descarga parcial

Tensión previa 128 kV

Voltaje de medición 87 kV, 5min, La evidente de descarga es de 5 pC

Voltaje de medición 50 kV, La evidente de descarga es de 2 pC

2、Prueba de celda electromagnética

2.1 Prueba de hermeticidad: No fuga_.

2.2 Señal para terminal de salida: Correcto_.

2.3 Medición de resistencia de aislamiento: (temperatura del ambiente 28 °C, Humedad relativa 51 %)

Devanado secundario , Devanado residual y a tierra: > 2000 MΩ,

Terminal de puesta a tierra de celda electromagnetic a devanado secundario , Devanado de tensión residual y a tierra: > 2000 MΩ.

2.4 Tensión soportada de inducción de devanado primario de transformador de media tensión 45.33kV, frecuencia 150Hz, 40s, probado.

2.5 Tensión soportada de inducción a tierra del lado de baja tensión de devanado primario de transformador de media tensión y devanado de reactor de compensación 4.61kV, frecuencia 150Hz, 40s, probado.

2.6 Tensión soportada de frecuencia industrial de Devanado secundario , Devanado residual y a tierra 3 kV, 1 min, probado.

2.7 Frecuencia tensión soportada en corte tiempo en el lado de puesta a tierra de transformador (E): 3kV (RMS), 1min.

2.8 Medición de la resistencia DC: (temperatura del ambiente 28 °C)

1a1n 0.0310 Ω, 2a2n 0.0604 Ω, dadn 0.0865 Ω.

2.9 Prueba del aceite de transformador: (NO. I-30°C)

Voltaje de ruptura \geq 50 kV.

Factor de disipación dieléctrica: $t=90^\circ\text{C}$ $\tan \delta \leq 0.005$

Contenido de humedad 13 mg/L

Análisis de cromatografía de gases

Unidad: $\mu\text{L/L}$

H ₂	CO	CO ₂	CH ₄	C ₂ H ₆	C ₂ H ₄	C ₂ H ₂	C1+C2
0	8	184	1.3	0	0.1	0	1.4

2.10 Prueba de la característica de excitación: Devanado residual sin amortiguador

devanado secundario 36.6V I= 2.51 A, P= 91.0 W

devanado secundario 55V I= 3.82 A, P= 205.3 W

Nota: Cuando hacen la prueba de tensión soportada de inducción y prueba sin carga, los pararrayos y amortiguadores deben ser desconectados, también transformadores intermedios y capacitores.

3、Prueba de la desviación después del ensamblaje

Regular el modo de conexión de devanado XT-NO-FE-BA-L3L4-L1							
Clase de precesión de terminal de la salida	U_n (%)	Carga (VA) $\text{COS } \Phi = 0.8$	f (%)	δ (')	Carga (VA) $\text{COS } \Phi = 0.8$	f (%)	δ (')
1a 1n 0.2	80	1a 1n 60 2a 2n 160	-0.12	+9	1a 1n 15 2a 2n 0	+0.10	+2
	100		-0.12	+9		+0.10	+2
	120		-0.12	+9		+0.10	+2
2a 2n 0.5	80	1a 1n 60 2a 2n 160	-0.25	+16	1a 1n 0 2a 2n 40	+0.10	+4
	100		-0.25	+16		+0.10	+4
	120		-0.25	+16		+0.10	+4
da dn 3P	2	1a 1n 60 2a 2n 160 da dn 320	-2.70	+88	1a 1n 0 2a 2n 0 da dn 80	-0.45	+40
	5		-2.80	+84		-0.55	+30
	100		-2.85	+76		-0.60	+22
	150		-2.85	+78		-0.65	+24

4、resonancia ferromagnética prueba Probado.

Conclusión

Este producto es probado con los requisitos de IEC61869—5, permitido para salir.

Editor: 孙晓燕

Aprobado por: 刘培富

Verificado por: 彭勇

Fecha: 2018-09-07



Product Code	Serial ID	Order ID	Line	Item	Customer Tag
R100S209NCAASZZZZ	14827506	10299546	1.1	1	
1700I11ABASZZZ	3411611	10299546	1.40	1	
PUCK700	25981873				

Process

Process ID : 7.21053402
 Process Time : 2018.08.02 16:46:47
 Process Stand : SSSC_CONFIG2@SSCC



Sensor

D1 : 0
 D2 : 1
 DFQ1 : 0
 DFQ2 : 0
 DT : 4.4
 DTG : 0
 Density Meter Factor : 1
 FCF : 274.39
 FD : 500
 FFQ : 0
 FT : 4.67
 FTG : 0
 Flow PCP : 30
 Flow PCF : 0
 K1 : 3635.379
 K2 : 4298.595
 Mass Flow Meter Factor : 1
 Volume Flow Meter Factor : 1

Units

Special Mass Total Text : NONE
 Special Volume Base Unit : L
 Special Volume Conv Factor : 1
 Special Volume Flow Text : NONE
 Special Volume Time Unit : SEC
 Special Volume Total Text : NONE
 Temperature Unit : C
 Volume Flow Unit : L/MIN

Assignments

Event 1 Variable : Density
 Event 2 Variable : Density
 Frequency1 Scaling Method : Frequency = Flow
 Frequency Variable 1 : Mass Flow Rate
 mA1 Variable : Mass Flow Rate

Ranges

Event 1 Setpoint : 0
 Event 1 Type : Event Low (Event "OFF" if PV > SP)
 Event 2 Setpoint : 0
 Event 2 Type : Event Low (Event "OFF" if PV > SP)

Frequency1 Active State : Active High
 Frequency1 Hertz : 1000
 Frequency1 Output Mode : Single
 Frequency1 Pulses/Unit : 0.2204623
 Frequency1 Rate : 4535.923
 Frequency1 Units/Pulse : 4.535923
 mA1 LRV : 0
 mA1 URV : 4535.923

Faults

Frequency1 Fault Behavior : Upscale
 Frequency1 Fault Value : 15000
 mA1 Fault Behavior : Downscale (Default)
 mA1 Fault Value : 2

Units

Density Unit : G/CM3
 GSV Flow Unit : SCFM
 Mass Flow Unit : G/SEC
 Pressure Unit : POUNDS/SQUARE INCH
 Special GSV Base Time Unit : MIN
 Special GSV Base Volume Unit : Standard cubic feet
 Special GSV Conv Factor : 1
 Special GSV Flow Unit Text : NONE
 Special GSV Total Text : NONE
 Special Mass Base Unit : G
 Special Mass Conv Factor : 1
 Special Mass Flow Text : NONE
 Special Mass Time Unit : SEC

Other

Calibration Process ID : 7.21048411
Core Software Rev : 35
 Density Cutoff : 0.2
 Density Damping : 1.6
 Density High Limit : 5
 Density Low Limit : 0
 Direction : FORWARD
 Fault Dwell Time : 0
 Feature Key : 2
 Flow Damping : 0.8
 HART Device ID : 3558445
 LD Type : 0
 Mass Flow Cutoff : 12.96
 Pressure Comp Line Pressure : 0
 Pressure Compensation State : OFF
 RS485 Baud : 1200 baud
 RS485 Parity : Odd
 RS485 Protocol : HART
 Slug Duration : 0
 Tag :
 Temperature Damping : 4.8
 Transmitter Software Rev : 80
 Volume Flow Cutoff : 0.7775999

ANEXO V

Datos característicos del grupo motor-generator

Datos técnicos

1720 kWel; 400 V, 50 Hz; Según análisis de gas

Condiciones de diseño

Temperatura de entrada / humedad del aire:	[°C] / [%]	25 / 60
Altura:	[m]	421
Temperatura de los gases de escape después del intercambiador:	[°C]	120
NO _x Emission	[mg/Nm ³ @5%O ₂]	250

Grupo:

Motor:	CG170-20	
Revoluciones:	[1/min]	1500
Configuración / número de cilindros:	[-]	V / 20
Diámetro / Carrera / Desplazamiento:	[mm]/[mm]/[dm ³]	170 / 195 / 89
Relación de compresión:	[-]	13,0
Velocidad media de pistones:	[m/s]	9,8
Consumo medio de aceite lubricante a plena carga:	[g/kWh]	0,15
Sistema de control del motor:	[-]	TEM EVO
Generador:	Marelli MJB 560 LB4	
Tensión / Rango de tensión / cos Phi:	[V] / [%] / [-]	400 / ±10 / 1
Revoluciones / Frecuencia:	[1/min] / [Hz]	1500 / 50

Datos de los gases de combustión ²⁾

Número de metano:	[-]	34
Valor calorífico inferior:	[kWh/Nm ³]	25,83
Densidad de gas:	[kg/Nm ³]	2,01
<i>Conforme a análisis de gas</i>		
Análisis: CO ₂	[Vol%]	0,00
N ₂	[Vol%]	0,00
O ₂	[Vol%]	0,00
H ₂	[Vol%]	0,00
CO	[Vol%]	0,00
CH ₄	[Vol%]	0,00
C ₂ H ₄	[Vol%]	0,00
C ₂ H ₆	[Vol%]	1,09
C ₃ H ₆	[Vol%]	0,11
C ₃ H ₈	[Vol%]	97,93
C ₄ H ₈	[Vol%]	0,00
C ₄ H ₁₀	[Vol%]	0,87
C ₅ H ₁₂	[Vol%]	0,00
C _x H _y	[Vol%]	0,00
H ₂ S	[Vol%]	0,00
H ₂ O	[Vol%]	0,00

Balance energético

Carga:	[%]	100	75	50
Potencia eléctrica COP conforme a ISO 8528-1:	[kW]	1720	1290	860
Energía del agua de refrigeración:	[kW ±8%]	799	616	440
Energía del intercambiador de calor BT:	[kW ±8%]	173	125	79
Energía del aceite de lubricación:	[kW ±8%]			
Energía de los gases de escape a temp. después del intercamb.:	[kW ±8%]	1020	847	640
Temperatura de los gases de escape:	[°C ±25°C]	461	486	515
Caudal húmedo de los gases de escape:	[kg/h]	9910	7622	5323
Caudal de aire de combustión:	[kg/h]	9592	7374	5148
Radiación motor / generador:	[kW ±8%]	64 / 49	59 / 43	51 / 39
Consumo de combustible:	[kW+5%]	4088	3183	2250
Eficiencia eléctrica / térmica:	[%]	42,1 / 44,5	40,5 / 46,0	38,2 / 48,0
Eficiencia total:	[%]	86,6	86,5	86,2

Parámetros del sistema ¹⁾

Flujo de aire de ventilación (incl. aire de combustión) a ΔT = 15K	[kg/h]	45900
Temperatura de aire de combustión mínima / diseño:	[°C]	5 / 25
Contrapresión de gas de escape de / a:	[mbar]	30 / 50
Pérdida máx. de presión de aire comb. frente al filtro de aire:	[mbar]	5
Sistema de control de baja presión seleccionable de / a: ²⁾	[mbar]	20 / 200
Sistema de control de alta presión seleccionable de / a: ²⁾	[bar]	0,5 / 10
Batería de arranque 24 V, capacidad necesaria:	[Ah]	450
Arranque:	[kWel.] / [VDC]	18 / 24
Contenido de aceite lubricante motor / bastidor base:	[dm ³]	300 / 685
Peso en vacío motor / grupo:	[kg]	8070 / 17620

Sistema de refrigeración

Contenido de glicol del circ. de refrig. del motor / de mezcla:	[% Vol.]	0 / 0
Contenido de agua del circ. de refrig. del motor / de mezcla:	[dm ³]	210 / 25
Valor Kvs / Cv del circ. de refrig. del motor / de mezcla:	[m ³ /h]	58 / 52
Circ. de refrigeración del motor entrada de agua / salida de agua:	[°C]	80 / 91
Circ. de refrigeración de mezcla entrada de agua / salida de agua:	[°C]	31 / 35
Caudal vol. de agua de refrig. del motor mín / máx:	[m ³ /h]	60 / 85
Caudal vol. de agua del circ. de refrig. del motor / de mezcla:	[m ³ /h]	64 / 40
Pérdida de pres. de agua del circ. de refrig. del motor / de mezcla:	[bar]	1,2 / 0,6

1) Consultar "Construcción de compl. energéticos"

2) Consultar TR 0199-99-3017

Banda de frecuencia	25	31,5	40	50	63	80	100	125	160	200	250	315	400	500	630	800	1k	1.25k	1.6k	2k	2.5k	3.15k	4k	5k	6.3k	8k	10k	12.5k	16k	L _{WA} [dB(A)]	S [m ²]
Ruido de aire ³⁾	94,9	96,9	98,0	100,0	106,3	111,3	111,7	118,9	113,6	116,3	116,8	112,2	111,6	114,2	111,5	111,1	112,2	110,5	111,3	111,4	109,2	107,2	105,7	105,9	109,4	120,3	104,7	99,1	98,6	123,8	140
L _{W, Terz} [dB(lin)]																															
Ruido de escape ⁴⁾	118,6	117,9	121,4	127,3	126,9	126,8	126,5	140,9	126,3	129,9	130,9	125,2	126,3	126,5	125,9	125,9	125,0	123,3	123,9	123,8	123,2	126,3	116,4	115,5	115,2	114,1	114,6	112,6	110,8	135,8	15,5 ⁵⁾
L _{W, Terz} [dB(lin)]																															

3) DIN EN ISO 3746 (σ₉₀=±4 dB)

4) Medido en el tubo de gases de escape (f ≤ 250Hz: ±5dB; f > 250Hz: ±3dB)

L_W: Nivel de potencia acústica

S: Superficie de medición (S₀=1m²)

5) DIN 45635-11 Anexo A



MarelliMotori
Inspired solutions

DREIPHASEN SYNCHRON GENERATOR
THREE-PHASE SYNCHRONOUS GENERATOR

MJB 560 LB 4

Wickelschema	Winding Code		80		
Wickelschritt	Winding Pitch		2/3		
Übertemperatur	Temperature Rise		F		
Isolationsklasse	Insulation		H		
Schutzart	Protection Degree		IP23		
Leistungsfaktor	Power Factor		0.8		
Drehzahl	Speed	1/min	1500		
Schleuderdrehzahl	Overspeed	1/min	2250		
Klemmenzahl	Number of Terminals		6		
Kühllufttemperatur	Cooling Temperature	°C	40		
Kühlart	Method of Cooling		IC01		
Kühlluftmenge	Cooling Air Volume	m ³ /s	3.00		
Aufstellungshöhe	Altitude at Site	m	1000		
Gewicht	Weight	kg	6850		
Trägheitsmoment	Inertia	kgm ²	98.00		
Gesamtverluste	Total losses	kW	60.5		
Strahlungswärme	Radiated Heat	kW	3.5		
FREQUENZ	FREQUENCY	Hz	50		
SPANNUNG	VOLTAGE (± 10%)	V	400		
STROM	CURRENT	A	3083		
NENNLEISTUNG	RATED POWER @ 0.8 p.f.	KVA	2136		
LEISTUNG - RATING	kVA	2136	1807	1720	1809
LEISTUNGSFAKTOR – POWER FACTOR	p.f.	0.80	0.95	1.00	0.95
WIRKUNGSGRAD – EFFICIENCY (%)	110%	96.62	97.13	97.31	97.20
	100%	96.58	97.06	97.23	97.14
	90%	96.51	96.95	97.11	97.01
	75%	96.30	96.68	96.83	96.77
	50%	95.43	95.71	95.84	95.81
	25%	92.30	92.48	92.61	92.64
			übererregt - overexcited		untererregt - underexcited
Reaktanzen - Reactances (%)				unsat	sat
Synchron, d-Achse	Synchronous, d-axis	Xd		194	186
Synchron, q-Achse	Synchronous, q-axis	Xq		108	106
Transient, d-Achse	Transient, d-axis	Xd'		21.4	16.6
Transient, q-Achse	Transient, q-axis	Xq'		108	106
Subtransient, d-Achse	Subtransient, d-axis	Xd''		12.7	10.0
Subtransient, q-Achse	Subtransient, q-axis	Xq''		14.1	11.1
Invers-System	Invers-Sequence	X2		13.4	10.5
Null-System	Zero-Sequence	X0		4.0	3.6
Widerstände - Resistances (%)					
Null-System	Zero-Sequence	R0		0.80	
Mit-System	Positive-Sequence	R1		0.75	
Invers-System	Negative-Sequence	R2		1.71	
Stator (@ 20°C)	Armature (@ 20°C)	Ra		0.54	
Zeitkonstanten - Time constants (s)					
Transient, d-Achse	Transient, d-axis ⁽¹⁾	T'd0		5.200	
Transient, d-Achse	Transient, d-axis ⁽²⁾	Td'		0.450	
Subtransient, d-Achse	Subtransient, d-axis ⁽²⁾	Td''		0.025	
Stator	Armature	Ta		0.055	
(1) Leerlauf - Open-circuit					
(2) Kurzschluss - Short-circuit					
Kurzschlussdaten - Short circuit data					
Anfangskurzschlusswechselstrom 3~, Effektivwert (kA)	Initial short circuit current 3~, rms value (kA)	Ik''		30.9	
Stoßkurzschlussstrom 3~, max. Momentanwert (kA)	Max. peak current 3~ (kA)	ip		73.7	
Dauerkurzschlussstrom 3~, Effektivwert (kA)	Sustained short circuit current 3~, rms value (kA)	Ik		≥9.25	
Leerlauf-Kurzschluss-Verhältnis	Short circuit ratio	Kc		0.54	
Stoßkurzschlussmoment 2~ (kNm)	Initial short circuit torque 2~ (kNm)	Mk2		203.0	
TVD bei Aufschaltung der Nennlast (%)	TVD at rated load step (%)	ΔU		12.1	
Max. Laststoss für ΔU = 15 % (kVA)	Max. load step at low PF for TVD = 15 % (kVA)	ΔSmax		2271	

Standard - Standards : VDE 0530 ; IEC 60034-1 ; BS 4999-5000

kWmech 1769
Datum - Date 16.11.2018



MarelliMotori
Inspired solutions

DREIPHASEN SYNCHRON GENERATOR
THREE-PHASE SYNCHRONOUS GENERATOR

MJB 560 LB 4

Generator Typenangaben - Generator type data (Rating)				
Nennleistung		Power	kVA	2136
Spannung		Voltage	V	400
Frequenz		Frequency	Hz	50
Drehzahl		Speed	1/min	1500
Verschaltungsart		Connection type		YN or Y
Rotortype		Rotor type		Salient
Reaktanzen - Reactances				
Synchron, d-Achse	(1)	Synchronous, d-axis	%	Xd
Synchron, q-Achse	(1)	Synchronous, q-axis	%	Xq
Transient, d-Achse	(1)	Transient, d-axis	%	Xd'
Transient, q-Achse	(1)	Transient, q-axis	%	Xq'
Subtransient, d-Achse	(1)	Subtransient, d-axis	%	Xd''
Subtransient, q-Achse	(1)	Subtransient, q-axis	%	Xq''
Invers-System	(1)	Invers-Sequence	%	X2
Null-System	(1)	Zero-Sequence	%	X0
Stator Streureaktanz	(1)	Stator leakage	%	XL
Kupplungsreaktanz (Hauptfeld/Dämpfer), d-Achse		Coupling (Main Field/Damper), d-axis	%	Xrld
Kupplungsreaktanz (Hauptfeld/Dämpfer), q-Achse		Coupling (Main Field/Damper), q-axis	%	Xrlq
Widerstände - Resistances				
Invers-System	(1)	Negative-Sequence	%	R2
Null-System	(1)	Zero-Sequence	%	R0
Stator (@ 20°C)	(1)	Armature (@ 20°C)	%	Ra
Zeitkonstanten - Time constants				
Transient, d-Achse	(1)	Transient, d-axis	s	Td'
Subtransient, d-Achse	(1)	Subtransient, d-axis	s	Td''
Transient, q-Achse	(1)	Transient, q-axis	s	Tq'
Subtransient, q-Achse	(1)	Subtransient, q-axis	s	Tq''
Stator	(1)	Armature (Stator)	s	Ta
Hauptfeld Parameter - Main field parameters				
Leerlaufstrom (Luftspalt)	(2)	No-load current (air gap)	A	I_FD-0
Leerlaufspannung	(2)	No-load voltage	V	E_FD-0
Nennstrom	(2)	Nominal current	A	I_FD-N
Nennspannung	(2)	Nominal voltage	V	E_FD-N
Sättigungsparameter bei 1.0 x Un		Saturation parameter at 1.0 x Un	%	S_G1.0
Sättigungsparameter bei 1.2 x Un		Saturation parameter at 1.2 x Un	%	S_G1.2
Parameter Erregermaschine - Exciter machine parameters				
Nenn-Erregerstrom		Nominal exciter field current	A	I_R-N
Nenn-Erreger Spannung		Nominal exciter field voltage	V	V_R-N
Leerlauf-Erreger Spannung		No-load exciter field voltage	V	V_R-0
Erreger-Ausgangsspannung, Sättigungspunkt 1	(2)	Exciter output voltage, saturation point 1	%	V_E1
Erreger-Sättigungsfaktor bei V_E1	(2)	Exciter saturation factor at V_E1	%	S_VE1
Erreger-Ausgangsspannung, Sättigungspunkt 2	(2)	Exciter output voltage, saturation point 2	%	V_E2
Erreger-Sättigungsfaktor bei V_E2	(2)	Exciter saturation factor at V_E2	%	S_VE2
Entmagnetisierungsfaktor	(2)	Demagnetizing factor	-	K_D
Erregerkonstante bezogen auf Eigenerregung	(2)	Exciter constant related to self-excited field	-	K_E
Erreger-Zeitkonstante	(2)	Exciter time constant	s	T_E
Min. Erreger-Ausgangsspannung	(2)	Minimum exciter output voltage	V	V_E-MIN
Max. Erreger-Ausgangsspannung		Maximum exciter output voltage	V	V_E-MAX
Gleichrichter Lastfaktor	(2)	Rectifier loading factor	-	K_C
Parameter Spannungsversorgung AVR - Voltage supply parameters for AVR				
Nenn-Versorgungsspannung		Nominal power supply voltage	V	V_PS-N
Maximale (Spitzen) Versorgungsspannung		Maximum (Peak) power supply voltage	V	V_PS-MAX
Weitere Parameter - Other parameters				
Trägheitsmoment		Rotor Inertia	kgm ²	J
Mechanische Dämpfung		Mechanical damping	p.u.	Dp
Anfangskurzschlusswechselstrom 3~, Effektivwert		Initial short circuit current 3~, rms value	kA	Ik''

Parameters stated with a tolerance of +/-10% (applicable where IEC std. define measurement procedure and tolerances)

Parameter mit einer Toleranz von +/-10% (anwendbar wo Meßverfahren und Toleranzen durch IEC Vorschrift definiert wird)

(1) Referenz bezogen auf IEC 60034-4 - Reference is given to IEC 60034-4

(2) Referenz bezogen auf IEEE 421.5 (Typ AC8B) - Reference is given to IEEE 421.5 (Type AC8B)

Datum - Date 16.11.2018



MarelliMotori
Inspired solutions

DREIPHASEN SYNCHRON GENERATOR
THREE-PHASE SYNCHRONOUS GENERATOR

MJB 560 LB 4

FREQUENZ	FREQUENCY	Hz	50
SPANNUNG	VOLTAGE (± 10%)	V	400
STROM	CURRENT	A	3083
NENNLEISTUNG	RATED POWER @ 0.8 p.f.	kVA	2136

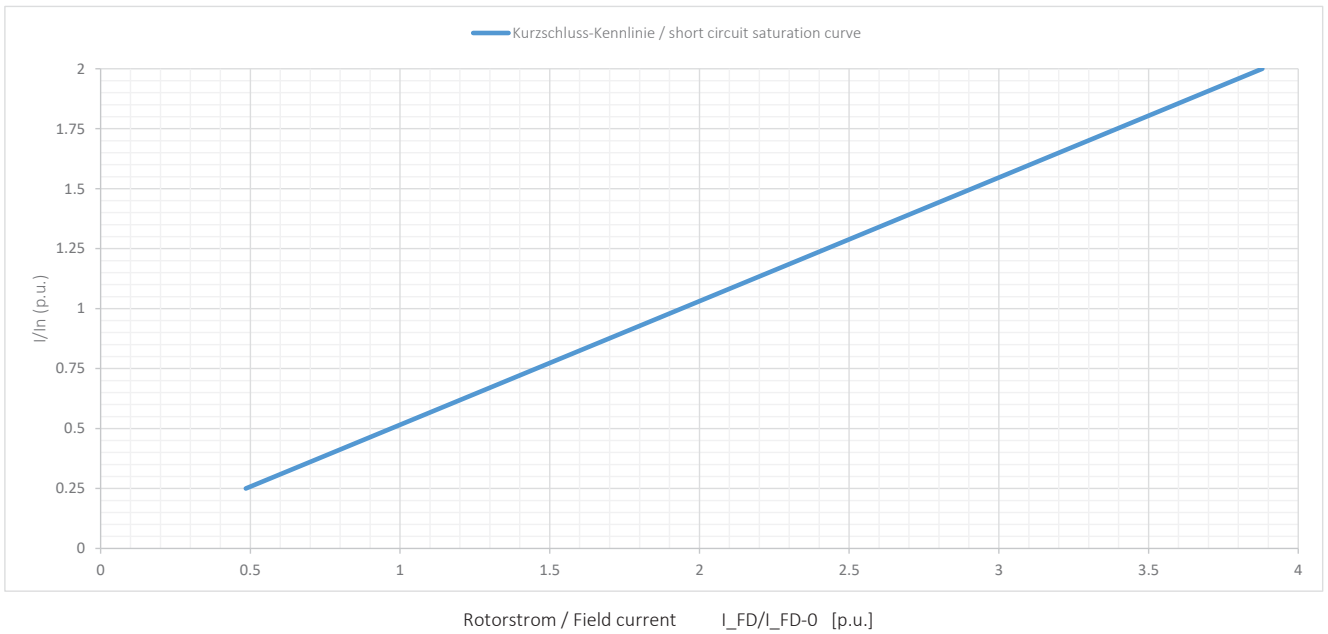
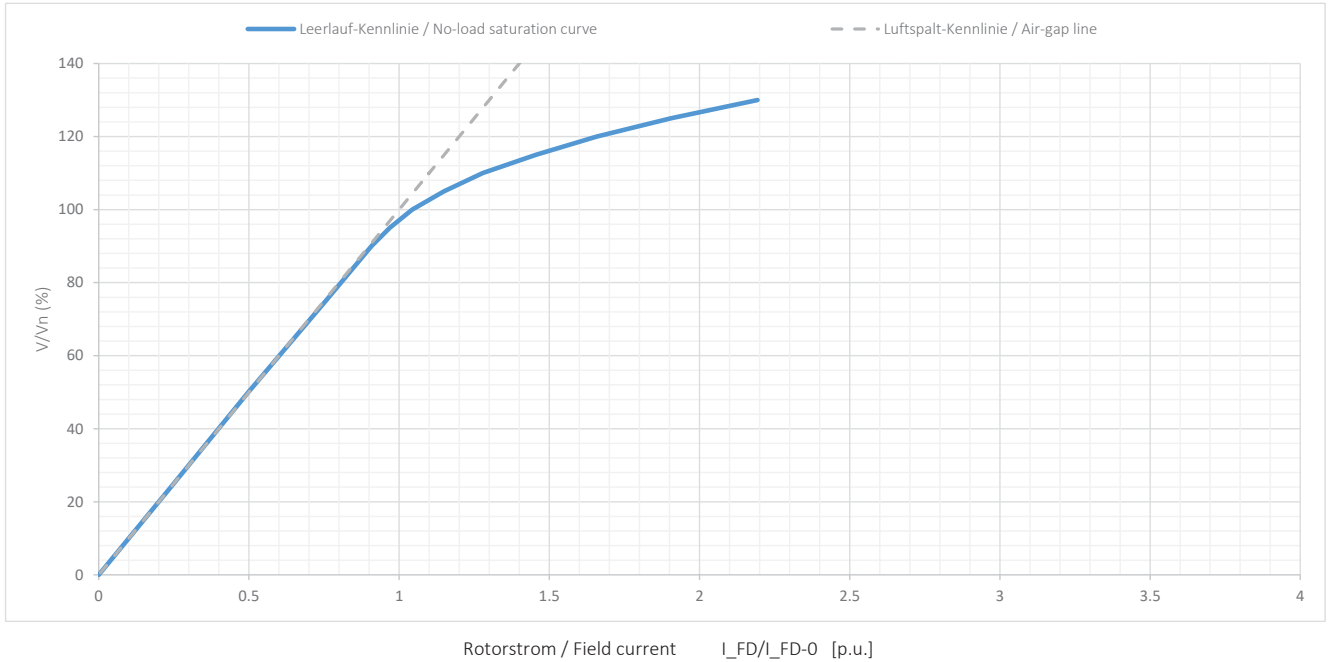

Datum - Date 16.11.2018



MarelliMotori
Inspired solutions

DREIPHASEN SYNCHRON GENERATOR
THREE-PHASE SYNCHRONOUS GENERATOR

MJB 560 LB 4

FREQUENZ	FREQUENCY	Hz	50
SPANNUNG	VOLTAGE (± 10%)	V	400
STROM	CURRENT	A	3083
NENNLEISTUNG	RATED POWER @ 0.8 p.f.	kVA	2136

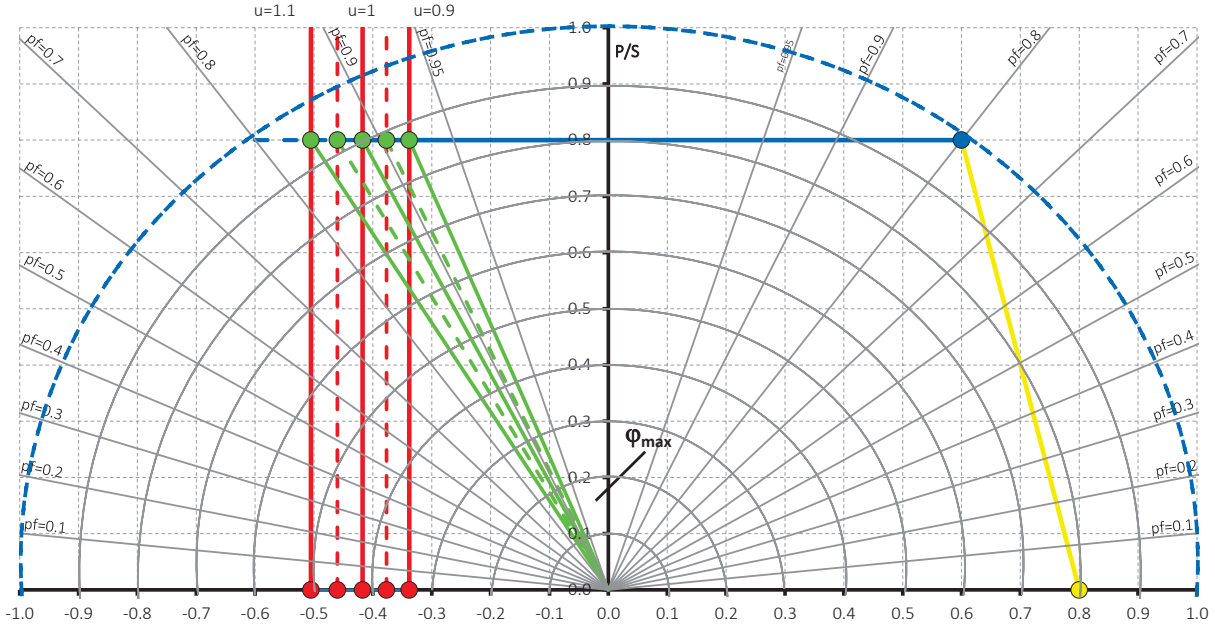

Q/S (untererregt / underexcited)

Q/S (übererregt / overexcited)

		U / Un					
		u=0.9	u = 0.95	u = 1	u = 1.05	u=1.1	
1)	QStab	722	805	892	983	1079	kVAr
2)	PStab p.f.=0,90	1492	1662	1841	2030	2228	kWe
	PStab p.f.=0,95	2198	2449	2713	2991	3283	kWe
3)	cosphi max	0.921	0.905	0.887	0.867	0.846	p.f.
	S	1855	1889	1928	1971	2021	kVA
	P	1709	1709	1709	1709	1709	kWe
4)	Q	722	805	892	983	1079	kVAr
	cosphi n	0.800	0.800	0.800	0.800	0.800	p.f.
	Sn	2136	2136	2136	2136	2136	kVA
5)	Pn	1709	1709	1709	1709	1709	kWe
	Qn	1282	1282	1282	1282	1282	kVAr
5)	QMax	1709	1709	1709	1709	1709	kVAr

Bemerkungen

- 1) Blindleistung QStab bei max. Untererregung (UE)
- 2) Theor. Wirkleistung bei QStab (max. UE)
- 3) Zul. Punkt bei QStab unter Einhaltung von SN und PN
- 4) Nennpunkt
- 5) Blindleistung bei max. Übererregung (ÜE)

Remarks

- 1) Reactive power QStab at max. under-excitation (UEXC)
- 2) Theor. active load at QStab (max. UEXC)
- 3) Perm. Point at QStab under consideration of SN and PN
- 4) Rated point
- 5) Reactive load at max. over-excitation

Datum - Date 16.11.2018

ANEXO VI

Certificado de análisis del combustible

INFORME DE ANÁLISIS GAS LICUADO DE PETRÓLEO GLP

INFORME N°: 518/19

FECHA: 21 de Octubre de 2019.

Fecha Muestreo: 11/10/2019

1.- IDENTIFICACIÓN DEL GAS LICUADO DE PETRÓLEO, GLP.

1.1. LUGAR DE MUESTREO: TANQUES TERMINAL GASMAR SA.

1.2. PRODUCTO SEGÚN ORIGEN: PROPANO

1.3. PROCEDENCIA DEL PRODUCTO: NAVE "NS FRONTIER"

2.- ANÁLISIS NCh. 72

INFORME	518/19-tk1	518/19-tk2	518/19-tk3	518/19-tk4	518/19-tk5	Concentración
Etano	1.20	0.85	0.04	1,16	0.92	% Vol.
Propano	97.02	97.41	2.55	97,33	97,77	% Vol.
Propileno	0,02	0,01	0.00	0,02	0,01	% Vol.
Iso- Butano	1.25	1.35	7.52	1.14	1.00	% Vol.
N- Butano	0.51	0.38	89.15	0,35	0,30	% Vol.
Neo-Pentano	0.00	0.00	0.25	0,00	0,00	% Vol.
I-Pentano	0,00	0,00	0.44	0,00	0,00	% Vol.
N-Pentano	0.00	0.00	0.05	0.00	0.00	% Vol.
	100	100	100	100	100	% Vol.

ANÁLISIS	UNIDAD	NORMA	518/19-tk1	518/19-tk2	518/19-tk3	518/19-tk4	518/19-tk5
Odorización (1)	----	NCh-2394	N/M	N/M	N/M	N/M	N/M
Corrosión lámina de Cobre	Clase	NCh-76	N°1	N°1	N°1	N°1	N°1
Temp. Ebull. Al 95% evaporación	°C	NCh-74	-39.8	-39.5	1.0	-39.4	-39.4
Contenido de Azufre antes Odorizar	ppmw	NCh-1962	2.9	3.3	3.5	2.4	2.9
Presión de Vapor a 37.8 °C	Kpag	NCh-77	1221	1211	277	1223	1217
Humedad	---	NCh-75	Cumple	Cumple	N/A	Cumple	Cumple
Agua Libre	---	NCh-75	N/A	N/A	No Contiene	N/A	N/A
Residuo en Evaporación de 100 mL.	ml	NCh-1940	<0.05	<0.05	<0.05	<0.05	<0.05
Observación Mancha de aceite	----	NCh-1940	Cumple	Cumple	Cumple	Cumple	Cumple
Densidad Relativa 60/60°F	---	NCh-1961	0.507	0.507	0.582	0.507	0.507
Butanos y más pesados	% vol.	NCh-1941	1.76	1.73	N/A	1.49	1.30
Pentanos y más pesados	% vol.	NCh-1941	N/A	N/A	0.74	N/A	N/A
Densidad Calculada (15°C)	K/L	ASTM 2598-16	0.5068	0.5073	0.5811	0.5067	0.5069

El presente informe es emitido por la Compañía en conformidad con sus condiciones Generales para los servicios de Inspección y ensayo. Este informe No debe ser reproducido parcial ni totalmente, sin la Autorización de Gasmar S.A

Apoquindo 3200, Piso 7, CP.:755-0183 Las Condes, Santiago, Chile ■ Teléfono (56 2) 23283200
Terminal: Quintero: Camino Concón, Puchuncavi s/n, Chile ■ Teléfono (56 32) 2794836-2794757

3.-OTROS ANÁLISIS

Análisis	UNIDAD	NORMA	518/19-tk1	518/19-tk2	518/19-tk3	518/19-tk4	518/19-tk5
Olefinas	% Vol.	NCh-1941	0.02	0.01	0.00	0.02	0.01
Diolefinas + Acetileno	ppm	NCh-1941	0.00	0.00	0.00	0.00	0.00
Butenos	% Vol.	NCh-1941	0.00	0.00	0.00	0.00	0.00
Pentenos y más pesados > C5	% Vol.	NCh-1941	0.00	0.00	0.00	0.00	0.00
Propeno	% Vol.	NCh-1941	0.02	0.01	0.00	0.02	0.01

Análisis	UNIDAD	NORMA	518/19-tk1	518/19-k2	518/19-tk3	518/19-tk4	518/19-tk5
Nº de Octanos Motor NOM	NOM	NCh-2435	95.4	95.4	N/A	95.4	95.4
Contenido Dienos (1,3 butadieno)	% mol	NCh-1941	0	0	N/A	0	0
Corrosión Lámina de Cobre(40°C)	Clase	NCh-76	1	1	N/A	1	1
Presión de Vapor a 40 °C	Kpaa	NCh-77	1393.25	1378.26	N/A	1393.58	1384.21
Presión Vapor Grado A (-10°C)	Kpaa	ISO 8973	361.71	356.30	N/A	361.67	358.21
Presión Vapor Grado B (-5°C)	Kpaa	ISO 8973	422.72	416.63	N/A	422.69	418.81
Presión Vapor Grado C (0°C)	Kpaa	ISO 8973	491.41	484.57	N/A	491.40	487.04
Presión Vapor Grado D (10°C)	Kpaa	ISO 8973	654.28	645.78	N/A	654.32	648.93
Residuo en Evaporación (Alta) (2)	mg/Kg	NCh-2441	0	0	N/A	0	0
Sulfuro de Hidrógeno (2)	---	ASTM2420	Cumple	Cumple	N/A	Cumple	Cumple

- (1) La odorización no es mandataria (N/M), para transporte en oleoductos y/o buques según NCh72.
 (2) Ensayo realizado por personal de SGS según Informe de análisis N° OS19-02180.
 N/A : No Aplica.

 Alejandro Lizama
 JEFE DE OPERACIONES

 Juan Carlos Aliaga T.
 Químico Analista

El muestreo y ensayos de análisis fueron efectuados por personal de LABCONTROL-GAS. Según dictamina las normas NCh73 Gases licuados de petróleo (GLP) – Parte 1 - Obtención de Muestras - Metodo manual. La NCh72 Gases Licuados de Petróleo (GLP) – Especificaciones y NCh 2115 Gases licuados de petróleo para uso automotriz – Especificaciones. Los límites de especificación referidos a NCh72 y NCh2115.



LABCONTROL-GAS

El presente informe es emitido por la Compañía en conformidad con sus condiciones Generales para los servicios de Inspección y ensayo. Este informe No debe ser reproducido parcial ni totalmente, sin la Autorización de Gasmar S.A

Apoquindo 3200, Piso 7, CP.:755-0183 Las Condes, Santiago, Chile ■ Teléfono (56 2) 23283200
 Terminal: Quintero: Camino Concón, Puchuncavi s/n, Chile ■ Teléfono (56 32) 2794836-2794757