



HPP PALMAR

Determinación de Máximo Técnico - Reporte Final

# Items

1.	Resumen ejecutivo	4
2.	Determinación de máximo técnico	5
3.	Placa de identificación	7
4.	Anexo	8

A	Primera emisión	Quaranta S.	Baralis G.	24/10/2019
<b>Rev.</b>	<b>Descripción</b>	<b>Dibujó</b>	<b>Revisó</b>	<b>Fecha</b>

# SCOTTA

Shape the innovation

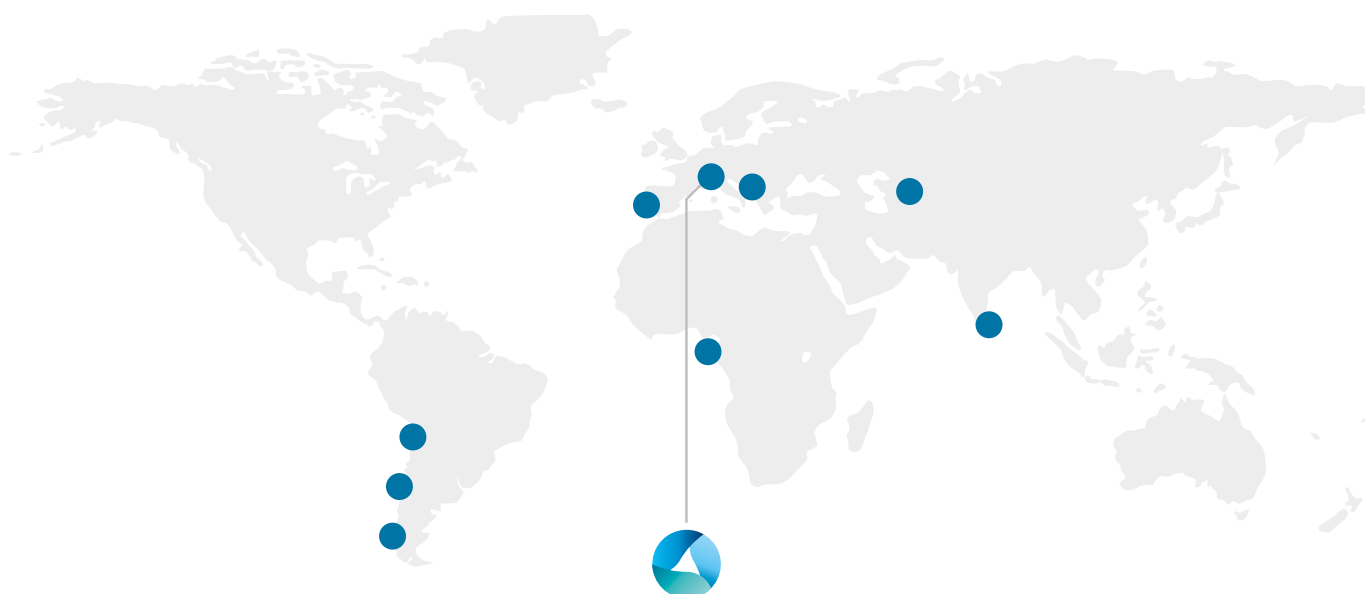

Villafalletto (CN) - Italy  
Via Monviso 41 - 12020  
Tel. 0171.935111  
Fax 0171.935150

[tecnico@scotta.it](mailto:tecnico@scotta.it)  
[www.scotta.it](http://www.scotta.it)



**CQOP SOA**  
CONSTRUTTORI QUALIFICATI OPERE PUBBLICHE

**Scotta S.p.A**  
Capitale sociale  
Euro 16.000.000,00 i.v.  
Codice Fiscale - Partita IVA -  
Registro Imprese di Cuneo:  
03429380045  
R.E.A. 290102  
C.C.I.A.A. Cuneo

# 1. Resumen ejecutivo

El propósito de este documento es reportar el máximo técnico de las unidades de la planta de PALMAR, Chile.

PALMAR es una planta hidráulica compuesto por 2 turbinas de agua de marca SCOTTA de potencia nominal de 4.334 kW cadauna, a 600 rpm. Los generadores son de marca GAMESA de potencia nom 5.200 kVA, 13.200 Volts y factor de potencia de 0.8.

El punto del Sistema Interconectado donde se inyecta la potencia activa de la planta es la “Subestación Palmar”.

Se analiza y concluye acerca de el siguiente valore de interés:

1. **Máximo Técnico**, correspondiente a la máxima potencia de salida para la cual la turbina exhibe una operación continua y estable.

El parámetro de máximo técnico se determina en base a antecedentes técnicos y de operación de la central.

El informe recoge información técnica relevante, principalmente proporcionada por el fabricante de la turbina a efectos de verificar los valores de interés.

La tabla 1, abajo ilustra los resultados del análisis:

Parámetros	Punto de medida	Información Técnica
Potencia bruta G1	Bornes generador	<b>máximo técnico 4.334 kW</b>
Potencia bruta G2	Bornes generador	<b>máximo técnico 4.334 kW</b>
Potencia SS.AA.*	Tablero distribución SS.AA.	<b>6 kW</b>
Perdidas en los transformadores elevadores *	Tablero media tensión	<b>86 kW</b>
Potencia neta *	Subestación Palmar	<b>8.576 kW</b>

*\* en condición de operación en Máximo Técnico*

## 2. Determinación de máximo técnico

**OBJETO** El objeto de este informe técnico es informar el valor del parámetro de máximo técnico de las turbinas hidráulicas de la central PALMAR.  
El material incluido en este informe considera la información técnica y los documentos indicados en el Anexo Técnico “Pruebas de Potencia Máxima en Unidad Generadoras”.

**DETERMINACIÓN DE MAXIMO TÉCNICO** En este informe, para la determinación del MT, se consideró la siguiente información:  
- Antecedentes técnicos de diseño.

**CONSUMO SERVICIOS AUXILIARIES** En fase de puesta en marcha, ha sido estimado en 6 kW el consumo de los servicios auxiliares de la central en la condición de operación en potencia máxima.

**ANTECEDENTES TÉCNICOS DE DISEÑO GENERADOR** Las Unidades de la Central PALMAR poseen un generador de potencia nominal de 5.200 [kVA] y una tensión nominal de 13.2 [kV].

### **TURBINA**

Las turbinas de las unidades son de tipo Pelton, marca SCOTTA, de eje vertical, y la potencia nominal es de 4.334 kW, velocidad de rotación nominal 600 rpm.

### **SISTEMA DE CONTROL VELOCIDAD-POTENCIA**

Las Turbinas de tipo Pelton no sufren cavitaciones por flujo de agua o diferencial de presión. La siguiente expresión muestra la relación entre potencia de bruta de salida de la unidad y flujo volumétrico (m<sup>3</sup>/s) de la turbina:

$$P_B = Q_v \times \rho \times g \times H_B$$

donde:

$P_B$	=	Energía eléctrica bruta, kW
$Q_v$	=	Caudal volumétrico turbinado, m <sup>3</sup> /s
$\rho$	=	Densidad del fluido turbinado, kg/m <sup>3</sup>
$g$	=	Aceleración de la gravedad, m/s <sup>2</sup>
$H_B$	=	Salto bruto, m

La potencia máxima de la turbina es vinculada al caudal máximo de los inyectores, que se puede determinar por medio de las siguientes formulas:

$$Q_v = \frac{V\pi d^2}{4} \quad V = \varphi\sqrt{2gH_n}$$

donde:

$Q_v$	=	Caudal volumétrico turbinado, m <sup>3</sup> /s
$V$	=	Velocidad de salida agua inyector, m/s
$H_n$	=	Salto neto, m
$g$	=	Aceleración de la gravedad, m/s <sup>2</sup>
$\varphi$	=	Coefficiente de flujo inyector (0,97)
$d$	=	Diámetro de salida del inyector

Con una apertura del 100% de 5 inyectores, en la turbina la potencia de salida es **4.334 kW** (condicion de máxima potencia).

#### PRUEBA EFECTUADA

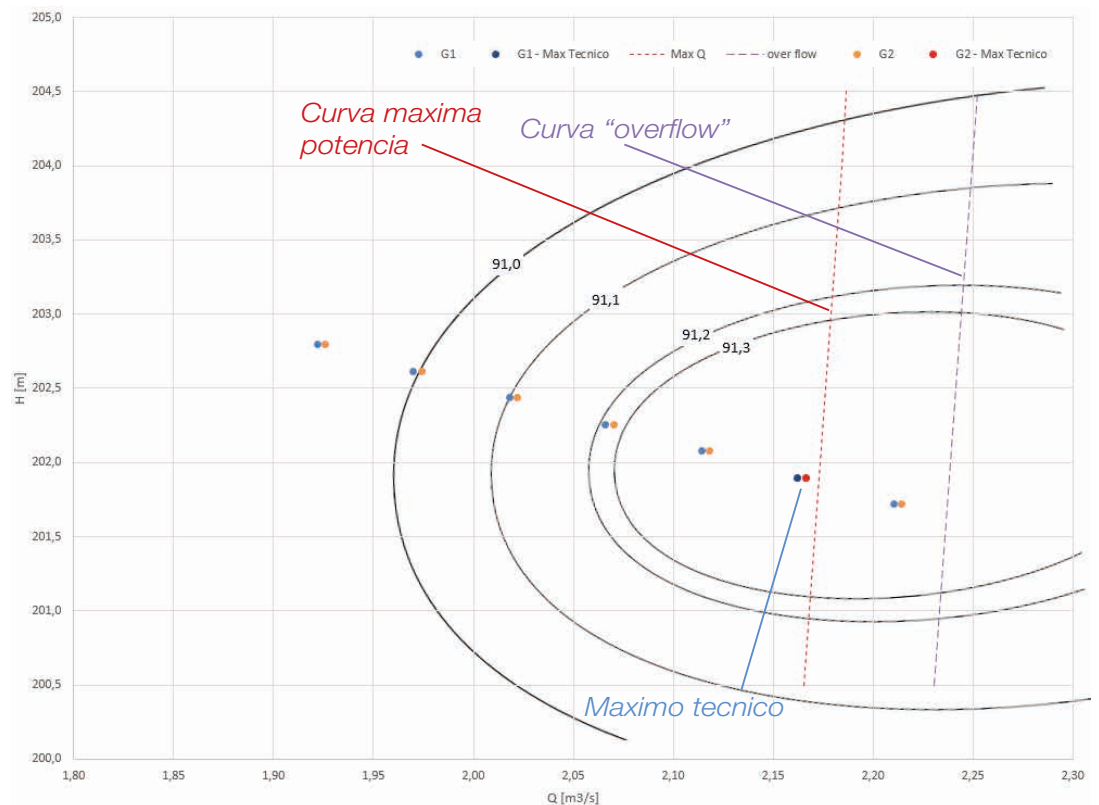

En fase de puesta en marcha de los grupos de producción, se llevó a cabo el test de eficiencia, en acuerdo con la especificación técnica adjunta.

En el siguiente gráfico se encuentran los resultados del test de eficiencia, comparados con la curva de colina de la turbina (5 inyectores), la curva de máxima potencia (vinculada al caudal máximo con apertura del 100% de 5 inyectores) y la curva de "overflow".



**CONCLUSIÓN** La potencia de máximo técnico de las unidad de la Central PALMAR es 4.334 kW cadauna.

### 3. Placa de identificación

Gamesa Electric						
III-PHASE SYNCHRONOUS GENERATOR						
Nº	Type PO 1000-U4F10		n 600 r.p.m. / 1050 r.p.m.		D.E. 	
P 5200 kVA - S1	cos φ 0.8	f 50 Hz	U <sub>1</sub> 13200 V	I <sub>1</sub> 227 A	3 ~ 	
IC 01	IM 4011	IP 23	U <sub>2</sub> 81.8 V	I <sub>2</sub> 589 A	DC	
Ambient T 40°C	Δ T 80°C	Cl F	IEC 60034	25000 Kg		
BRUSHLESS EXCITATION SYSTEM						
Nº	Type EDR 5715 14/10		f 70 Hz	cos φ 0.95		
P 59 kVA	U <sub>1</sub> 68 V	I <sub>1</sub> 503 A	3 ~ 			
P 48,2 kW	U <sub>1</sub> 81,8 V	I <sub>1</sub> 589 A	DC			
EXCITACION	U <sub>2</sub> 124,3V	I <sub>2</sub> 11 A	DC			
GAMESA ELECTRIC S.A.U. P.º de A. Calonge 3 REINOSA (CANTABRIA) SPAIN			Tel. 0034942 77 41 00 Fax. 0034942 75 32 50 e-mail: gamesaelectric@gamesacorp.com			

**SCOTTA**  **CE**

Type:   
 Serial number:   
 Year of production:   
 Turbine output:   
 Head:  Turbine speed:

**MADE IN ITALY**

*Placa Unidad "G1"*

**SCOTTA**  **CE**

Type:   
 Serial number:   
 Year of production:   
 Turbine output:   
 Head:  Turbine speed:

**MADE IN ITALY**

*Placa Unidad "G2"*

## 4. Anexo

Se adjunta un pasaje de la prueba de eficiencia de la turbina y la especificación técnica de la prueba.



**RELAZIONE COLLAUDO CENTRALE DOS VALLES**

N° collaudo	CL-02-2017	DATA	07/07/2018	COMMESSA		REDAZIONE	G.M.BARALIS	CONTROLLO	SCOTTA
CENTRALE	PALMAR			CLIENTE	HIDRO PALMAR				

**ELABORATO DI COLLAUDO E PROVE DI MESSA  
IN MARCIA**

**CENTRALE PALMAR**

**TURBINA PELTON 5 GETTI**

**ASSE VERTICALE**

**G1 e G2**





SCOTTA S.p.A. Sede  
legale e amministrativa: Via Monviso,41 - 12020 VILLAFALLETTO (CN) Tel.0171/935111-  
Fax:0171/935150



PROVE PARALLELO GRUPPO 1

POTENCIA HIDRAULICA	POTENCIA ELECTRICA	CAUDAL	CAIDA NETA IEC 60041	INJECTOR					NOTE
				1	2	3	4	5	
kW	kW	m <sup>3</sup> /s	m	%	%	%	%	%	
99	63	0,048	209,82	10					minimo tecnico
198	138	0,096	209,64	20					
296	254	0,144	209,46	30					
395	349	0,192	209,28	40					
493	441	0,240	209,10	50					
591	535	0,288	208,92	60					
689	627	0,336	208,74	70					
786	717	0,384	208,56	80					
884	804	0,432	208,38	90					
981	891	0,480	208,20	100					
1.078	971	0,528	208,02	100	10				
1.175	1.064	0,577	207,84	100	20				
1.272	1.158	0,625	207,66	100	30				
1.369	1.247	0,673	207,48	100	40				
1.466	1.337	0,721	207,30	100	50				
1.562	1.424	0,769	207,12	100	60				
1.658	1.512	0,817	206,94	100	70				
1.754	1.598	0,865	206,76	100	80				
1.850	1.683	0,913	206,58	100	90				
1.946	1.767	0,961	206,40	100	100				
2.041	1.853	1,009	206,22	100	100	10			
2.136	1.944	1,057	206,04	100	100	20			
2.232	2.035	1,105	205,86	100	100	30			
2.327	2.124	1,153	205,68	100	100	40			
2.421	2.211	1,201	205,50	100	100	50			
2.516	2.295	1,249	205,32	100	100	60			
2.610	2.381	1,297	205,14	100	100	70			
2.705	2.464	1,345	204,96	100	100	80			
2.799	2.547	1,393	204,78	100	100	90			
2.893	2.630	1,441	204,60	100	100	100			
2.987	2.709	1,489	204,42	100	100	100	10		
3.080	2.803	1,537	204,24	100	100	100	20		
3.174	2.898	1,585	204,06	100	100	100	30		
3.267	2.986	1,633	203,88	100	100	100	40		
3.360	3.068	1,682	203,70	100	100	100	50		
3.453	3.153	1,730	203,52	100	100	100	60		
3.546	3.234	1,778	203,34	100	100	100	70		
3.639	3.318	1,826	203,16	100	100	100	80		
3.731	3.399	1,874	202,98	100	100	100	90		
3.823	3.479	1,922	202,80	100	100	100	100		
3.915	3.563	1,970	202,62	100	100	100	100	10	
4.007	3.651	2,018	202,44	100	100	100	100	20	
4.099	3.738	2,066	202,26	100	100	100	100	30	
4.191	3.826	2,114	202,08	100	100	100	100	40	
4.282	3.914	2,162	201,90	100	100	100	100	50	
4.373	3.997	2,210	201,72	100	100	100	100	60	
4.464	4.076	2,258	201,54	100	100	100	100	70	
4.555	4.159	2,306	201,36	100	100	100	100	80	
4.646	4.242	2,354	201,18	100	100	100	100	90	
4.737	4.325	2,402	201,00	100	100	100	100	100	maximo tecnico
5.187	4.720	2,642	200,10	110	110	110	110	110	overflow turbina



SCOTTA S.p.A.

Sede

legale e amministrativa: Via Monviso,41 - 12020 VILLAFALLETTO (CN) Tel.0171/935111-  
Fax:0171/935150

## PROVE PARALLELO GRUPPO 2

POTENCIA HIDRAULICA	POTENCIA ELECTRICA	CAUDAL	CAIDA NETA IEC 60041	INJECTOR					NOTE
				1	2	3	4	5	
kW	kW	m <sup>3</sup> /s	m	%	%	%	%	%	
107	69	0,052	209,81	10					minimo tecnico
206	144	0,100	209,63	20					
304	261	0,148	209,45	30					
403	356	0,196	209,27	40					
501	448	0,244	209,09	50					
599	543	0,292	208,91	60					
697	634	0,340	208,73	70					
794	725	0,388	208,55	80					
892	812	0,436	208,37	90					
989	898	0,484	208,19	100					
1.087	978	0,532	208,01	100	10				
1.184	1.071	0,581	207,83	100	20				
1.280	1.165	0,629	207,65	100	30				
1.377	1.254	0,677	207,47	100	40				
1.474	1.344	0,725	207,29	100	50				
1.570	1.432	0,773	207,11	100	60				
1.666	1.519	0,821	206,93	100	70				
1.762	1.605	0,869	206,75	100	80				
1.858	1.691	0,917	206,57	100	90				
1.954	1.774	0,965	206,39	100	100				
2.049	1.860	1,013	206,21	100	100	10			
2.144	1.951	1,061	206,03	100	100	20			
2.239	2.042	1,109	205,85	100	100	30			
2.334	2.131	1,157	205,67	100	100	40			
2.429	2.218	1,205	205,49	100	100	50			
2.524	2.302	1,253	205,31	100	100	60			
2.618	2.388	1,301	205,13	100	100	70			
2.713	2.471	1,349	204,95	100	100	80			
2.807	2.554	1,397	204,77	100	100	90			
2.901	2.637	1,445	204,59	100	100	100			
2.994	2.716	1,493	204,41	100	100	100	10		
3.088	2.810	1,541	204,23	100	100	100	20		
3.182	2.905	1,589	204,05	100	100	100	30		
3.275	2.993	1,637	203,87	100	100	100	40		
3.368	3.075	1,686	203,69	100	100	100	50		
3.461	3.160	1,734	203,51	100	100	100	60		
3.554	3.241	1,782	203,33	100	100	100	70		
3.646	3.325	1,830	203,15	100	100	100	80		
3.739	3.406	1,878	202,97	100	100	100	90		
3.831	3.486	1,926	202,79	100	100	100	100		
3.923	3.570	1,974	202,61	100	100	100	100	10	
4.015	3.658	2,022	202,43	100	100	100	100	20	
4.107	3.745	2,070	202,25	100	100	100	100	30	
4.198	3.833	2,118	202,07	100	100	100	100	40	
4.290	3.921	2,166	201,89	100	100	100	100	50	
4.381	4.004	2,214	201,71	100	100	100	100	60	
4.472	4.083	2,262	201,53	100	100	100	100	70	
4.563	4.166	2,310	201,35	100	100	100	100	80	
4.654	4.249	2,358	201,17	100	100	100	100	90	
4.744	4.331	2,406	200,99	100	100	100	100	100	maximo tecnico
5.194	4.727	2,646	200,09	110	110	110	110	110	overflow turbina

**SCOTTA S.p.A.**

Capitale sociale Euro 16.000.000,00 i.v.

Codice Fiscale - Partita IVA - Registro Imprese di Cuneo:  
03429380045

R.E.A. 290102 C.C.I.A.A. Cuneo

Sede legale e amministrativa:

**Via Monviso, 41 - 12020 VILAFALLETTO (CN)**

**Tel.: 0171/935111 - Fax: 0171/935150**

# SCOTTA



# SAPIENZA TECNOLOGICA

*EXECUTION OF TEST FOR THE DETERMINATION OF*

*THE STEADY STATE PERFORMANCE OF THE MACHINE*



Turbine group efficiency measures are performed with reference to the IEC standard 41 (equivalent to the Italian standard CEI EN 60041):

"Field acceptance tests to determine the hydraulic performance of hydraulic turbines, storage pumps and pump-turbines".

In particular, the following procedure must be followed:

1. Instantaneous power measurement produced (chapter 9 of the Italian standard CEI EN 60041: 1997-11);
2. The Net Hydraulic Head measurement of the turbine (chapter 2 of the Italian CEI EN 60041: 1997-11);
3. Turbine discharge measurement (chapter 10 of the Italian standard CEI EN 60041: 1997-11);
4. Calculation and analysis of the results (chapter 8 of the Italian standard CEI EN 60041: 1997-11).

## **1 - MEASUREMENT OF THE INSTANT PRODUCT POWER**

Measurement of instantaneous power produced is detected in stable working conditions (for example: parameters 2-Net head and 3-Discharge variables in the instrument precision field) in two ways:

- a. By reading the production counter at 15min intervals;
- b. By reading the power value on the multifunction instrument (Network Analyzer), net of the self-consumption of the system. It's necessary to compare the reading with the production counter value at least twice to check the correspondence.

## **2 - MEASUREMENT OF THE NET HYDRAULIC JUMP OF THE TURBINE**

Net Head turbine measurement is got by reading the precision pressure gauge installed on the penstock immediately downstream of the machine valve, immediately upstream of the turbine spiral case. Through a geometric measurement of the position of the runner quote compared to the center of the manometer and considering the kinetic energy possessed by the incoming fluid, the net Head is got.

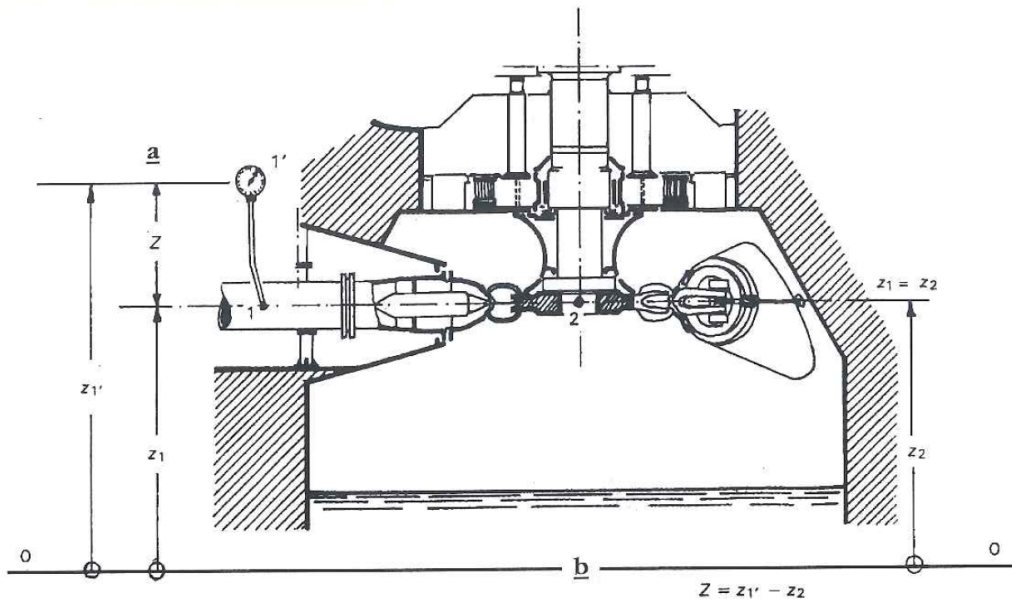

$$H_n = p_1 + \frac{U_1^2}{2g} + z$$

Whit:

$H_n$  = net Head [m];

$p_1$  = pressure gauge [m];

$U_1$  = kinetic energy calculated in manometre section [m/s];

$g$  = gravity acceleration [m/s<sup>2</sup>];

$z$  = geometric measurement of the position of the runner quote compared to the center of the manometer [m].

### 3 - MEASURED TURBINED DISCHARGE

Turbinated discharge is measured using a CLAMP-ON ultrasonic meter installed on the penstock in a position that the measuring section has 10 straight diameters upstream and 5 straight diameters downstream of the pipeline.

Pipe diameter will define the number of acoustic path and the measuring well size where the acoustic meter must be installed.

For this hydroelectric power plant, penstock has a nominal diameter of DN600. Therefore, it is proposed to install a CLAMP-ON ultrasonic meter with 2 acoustic paths installed near the central building at a distance of at least 3m upstream from the machine valve if the incoming supply line is straight for at least 10m.

Otherwise it will be necessary to find a position of the measuring well that respects the stated straight diameters. The well must have the following dimensions:

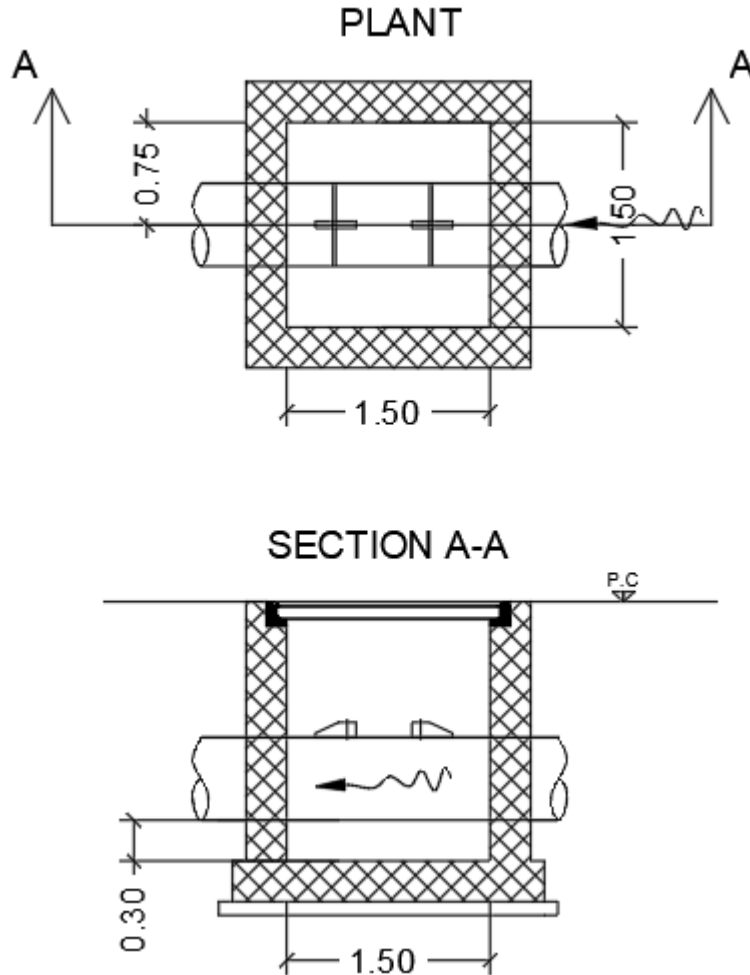

#### 4 - ANALYSIS OF RESULTS

In cases where it's not possible to carry out tests under contract conditions, the measured values can be transposed to the guarantee values only if the physical quantities variations involved (head H, speed U and power P) deviate from the contractual values inside the range  $\pm 10\%$  of the physical quantity itself.